

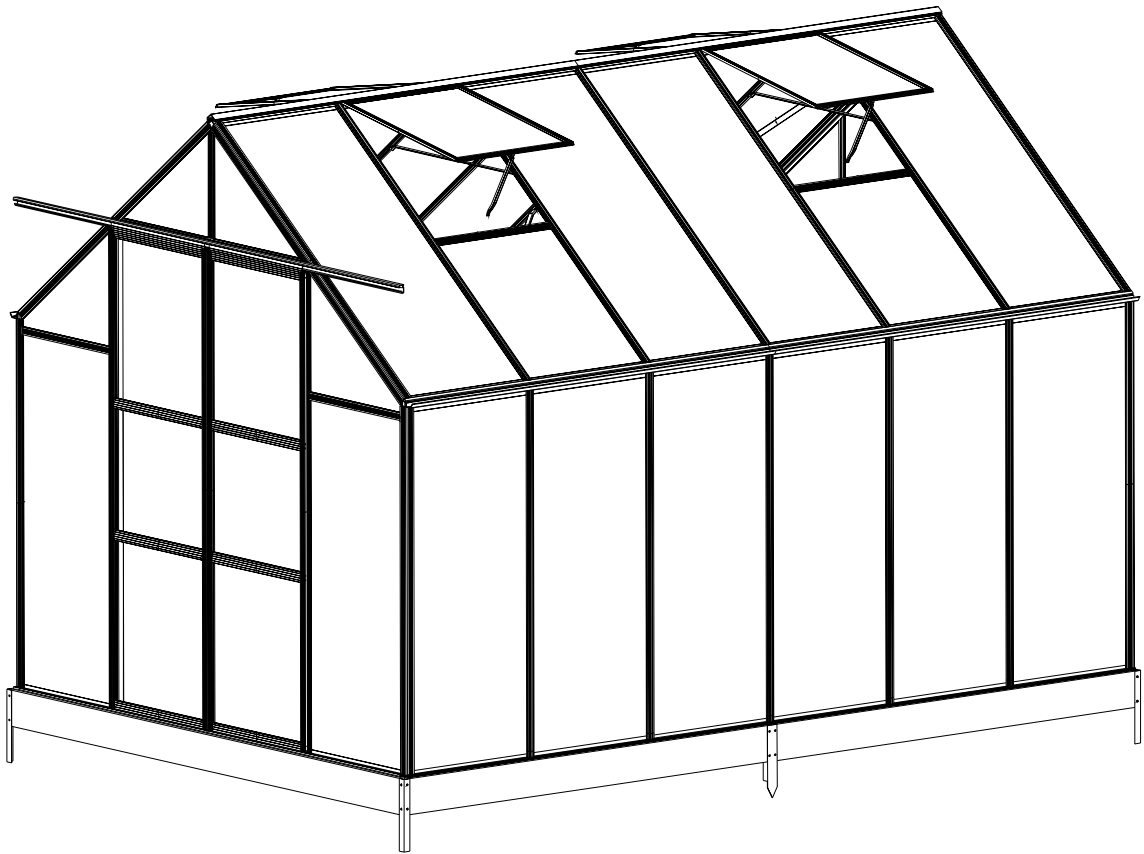

Assembly instruction



MODEL:GM31036-6-610

PRODUCT SIZE(LxWxH):381X257X205CM

PLEASE READ CAREFULLY BEFORE ASSEMBLY

Part	NO.	QTY.
	W05	19
	S01	24
	M01	24

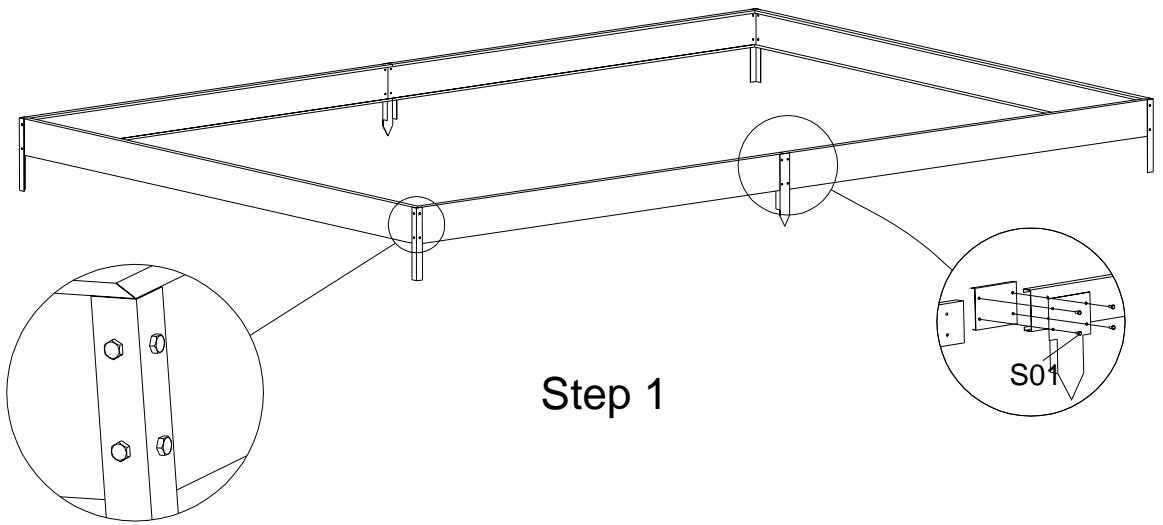

Step 1

When fixing the greenhouse with the base, please loosen the screws of the greenhouse and then fix the W05 with it. There are no extra screws for the base.

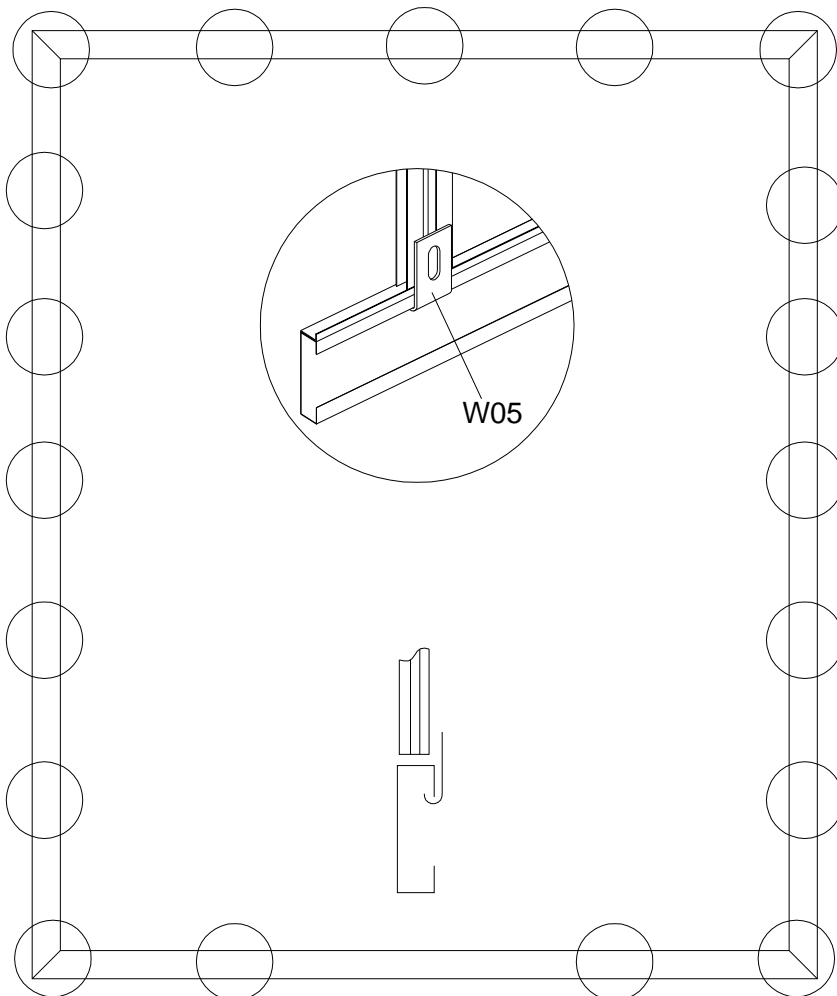

1/2

Step 2

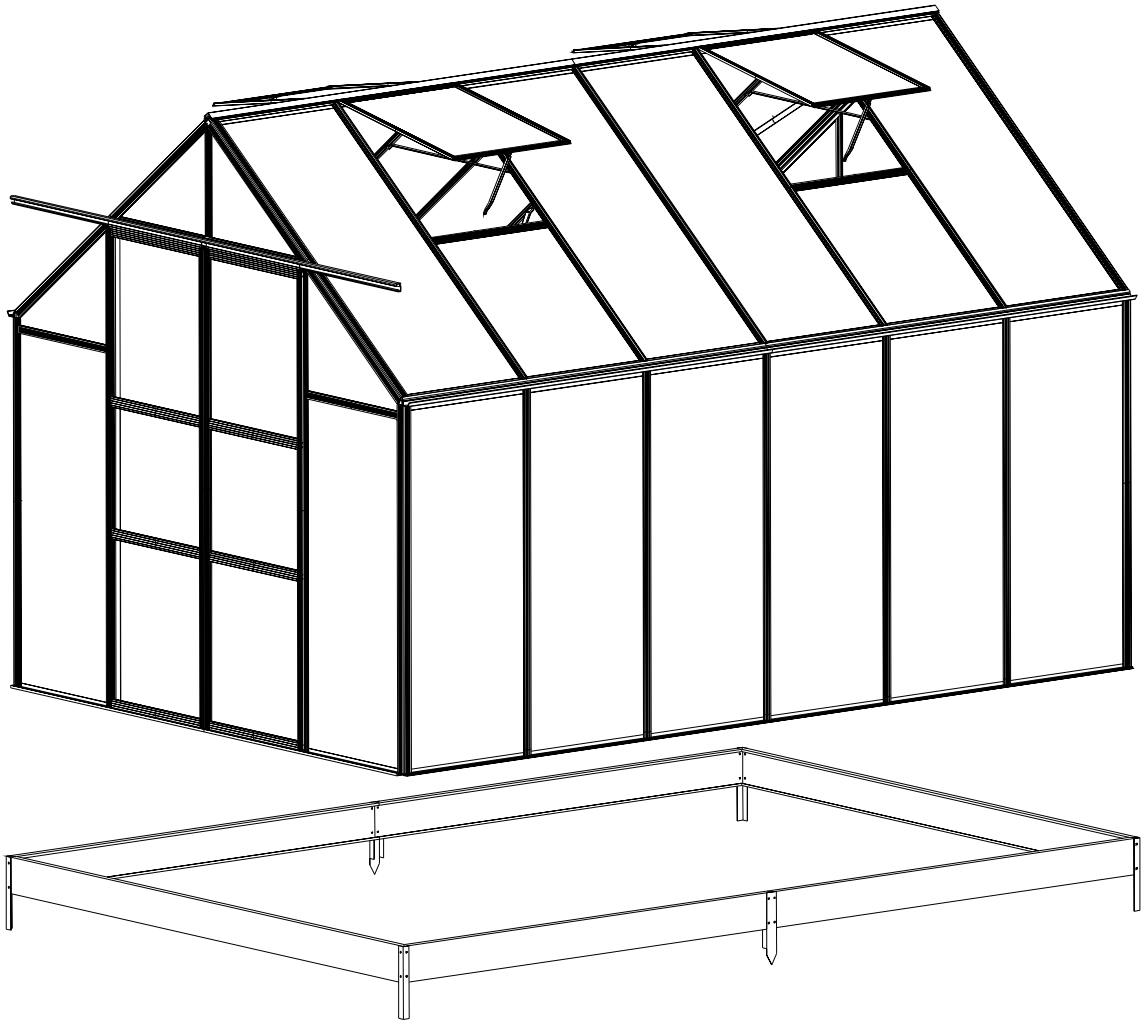



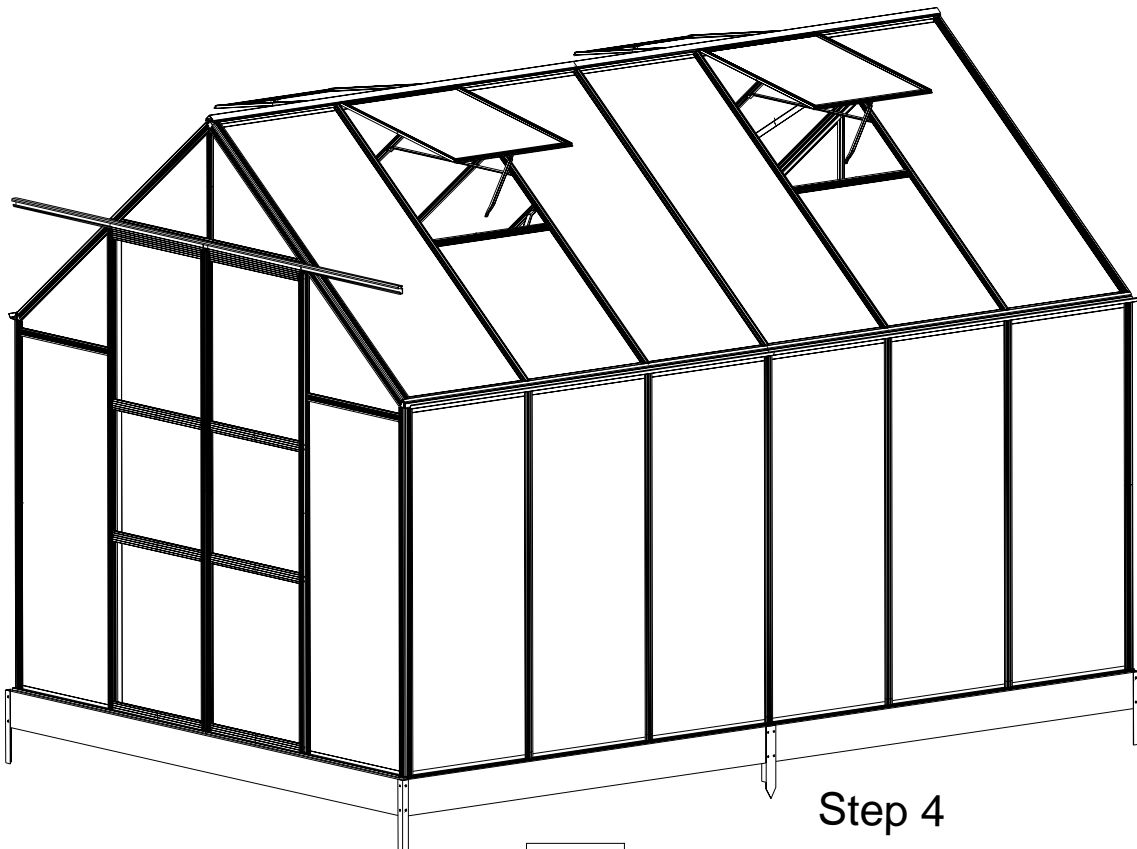



Step 3





Step 4











P2 -P3Door Frame Assembly

Part	NO.	QTY.
	L18A	3
	L18B	1
	L15	2
	L16A	1
	L16B	3
	L17	2













P4 Roof Vent Frame Assembly

Part	NO.	QTY.
	L19	8
	L20	4
	L21	4











(P5-P7) Back Assembly

Part	NO.	QTY.
	L01A	1
	L01B	1
	L01C	2
	L03B	4
	L02C	1
	L02D	1
	L02E	1
	L05A	2
	L08A	1
	L09	1

















(P8-P11)Front Assembly

Part	NO.	QTY.
	L01A	1
	L01B	1
	L01D	1
	L01E	1
	L03A	1
	L03B	2
	L03T	1
	L04A	1
	L04B	1
	L05A	2
	L05B	2
	L10	1
	L14	1













(P12-P23)Assembly

Part	NO.	QTY.
	L02A	10
	L02B	10
	L03B	4
	L05C	4
	L05D	4
	L05E	5
	L05F	10
	L06	1
	L07	2
	L08B	2

PARTS

Part	NO.	QTY.
	W06	4
	W08	4
	W01	2
	W02	4
	W03	2
	W04	11
	S02 M6X20	2
	M01 M6	152
	S01 M6X12	150
	Z01 Ø4X25	32
	Z02 Ø4X16D	16
	Z03 Ø4X10	10
	J01	2
	J02L/R	2/2
	J03L/R	1/1
	J04	1

Polycarbonate

Part	NO.	QTY.
	Y1	2
	Y2	6
	Y3	1
	Y4	2
	Y5	1
	Y6	12
	Y7	8
	Y8	1
	Y9	4
	Y10	4
	Y11	4
	Y12	2
	Y13	1

Part	NO.	QTY.
	L18A	3
	L18B	1
	L15	2
	L16A	1
	L16B	3
	L17	2

P2 Door1 Frame Assembly

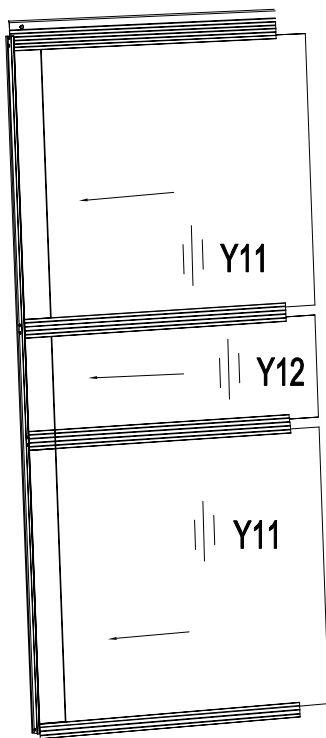
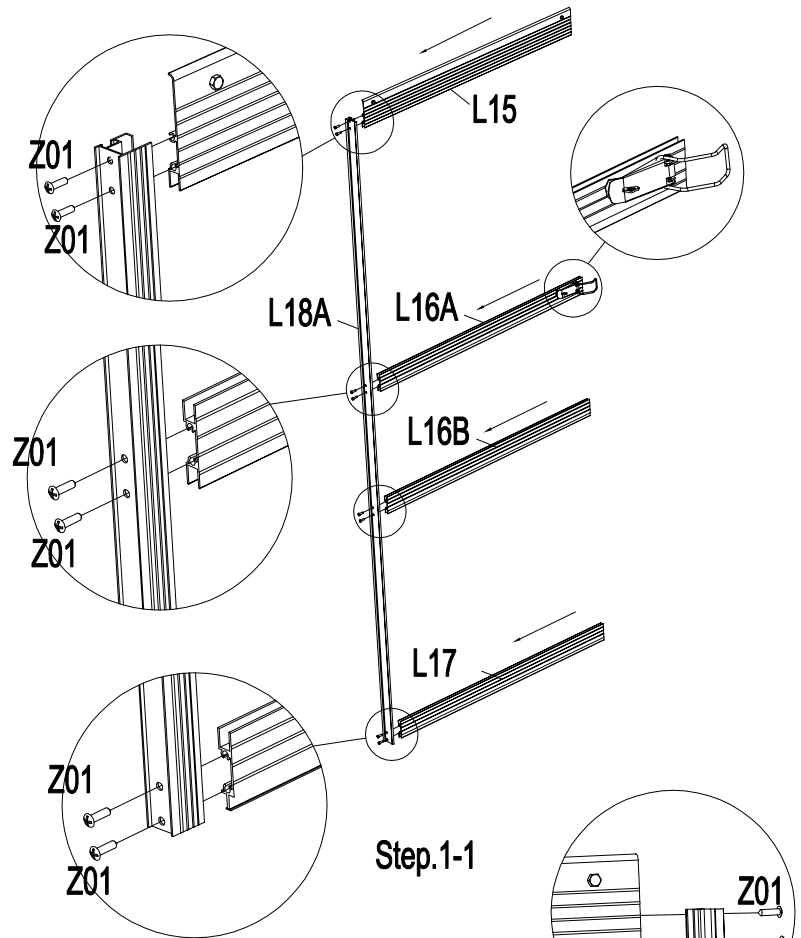

Step.1-2

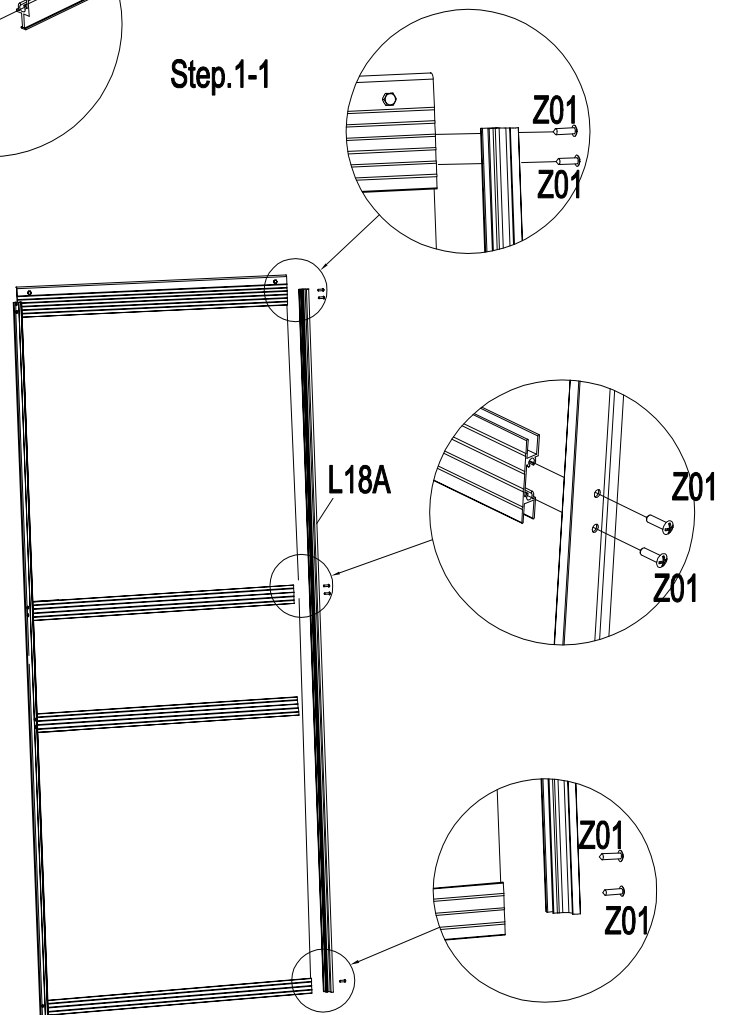

Step.1-3

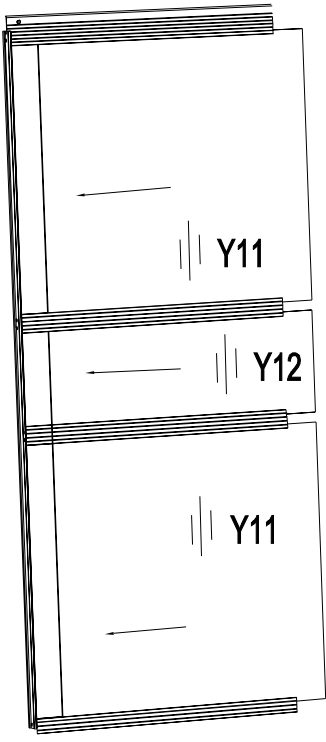
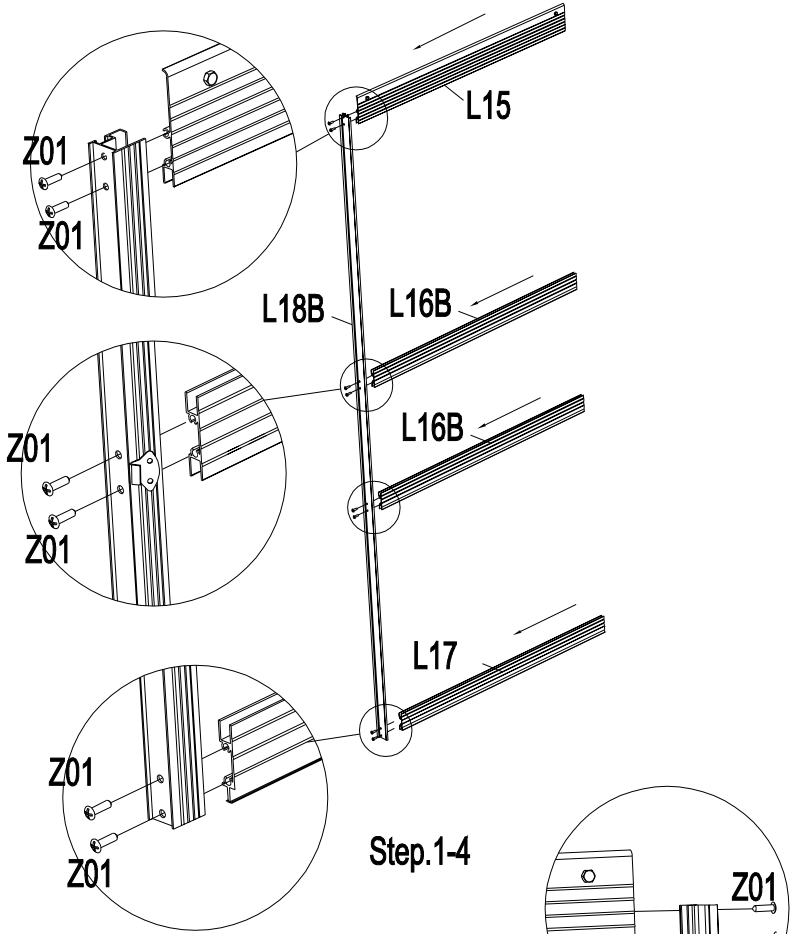

P3 Door2 Frame Assembly

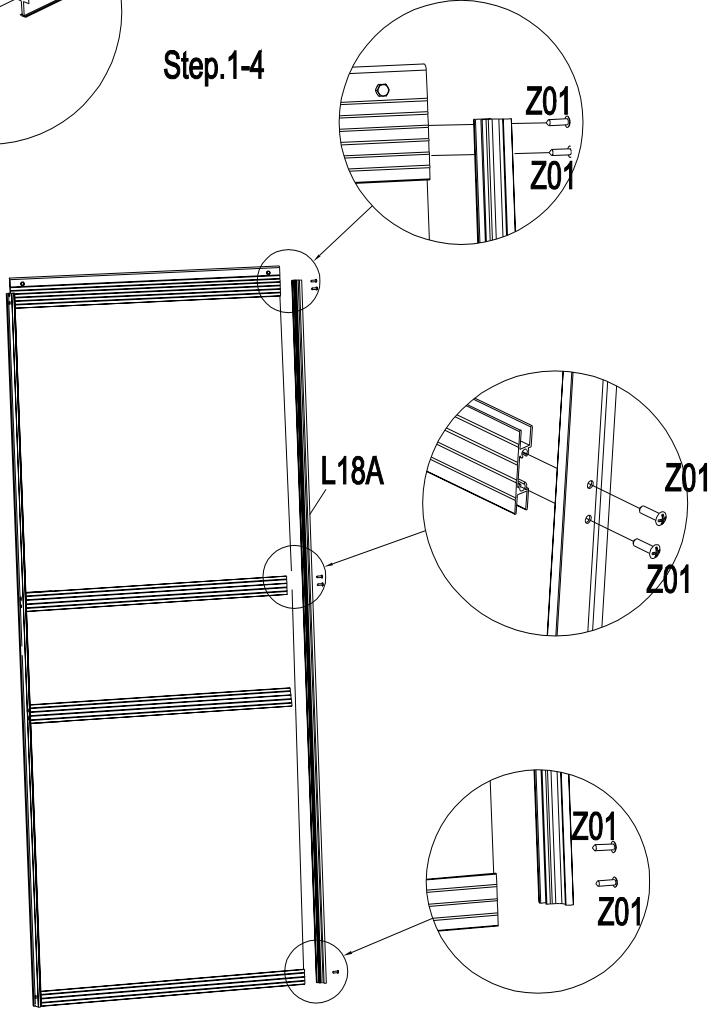

Step.1-5



Step.1-6

Part	NO.	QTY.
	L19	8
	L20	4
	L21	4

P4 Roof Vent Frame Assembly

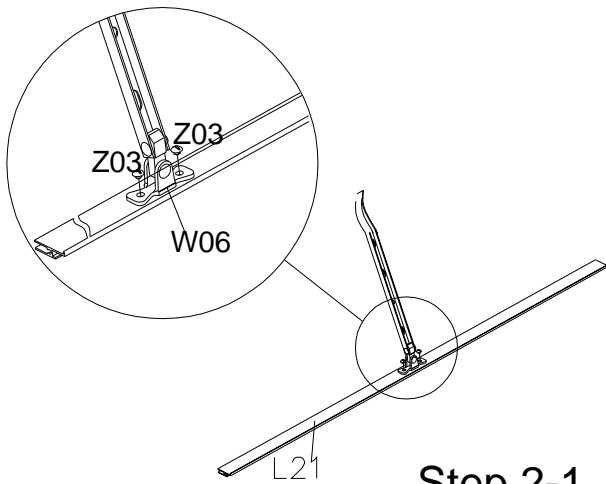
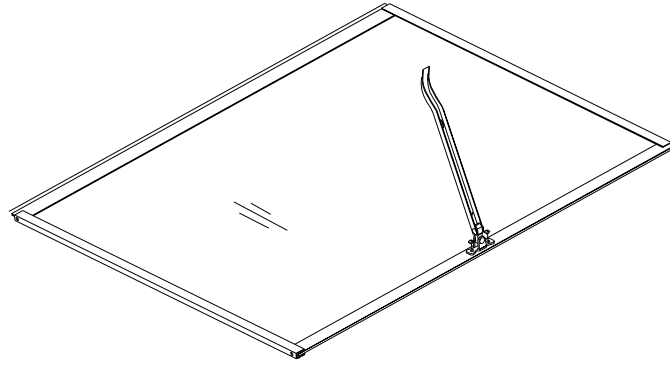



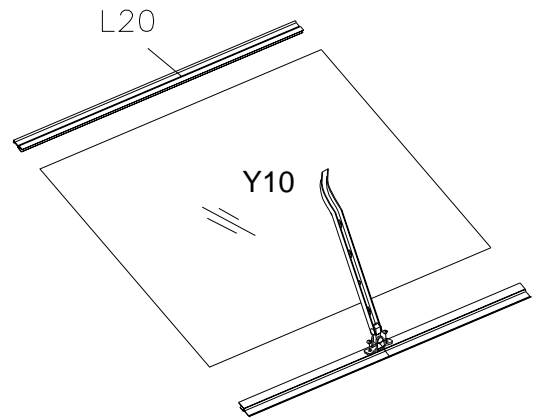



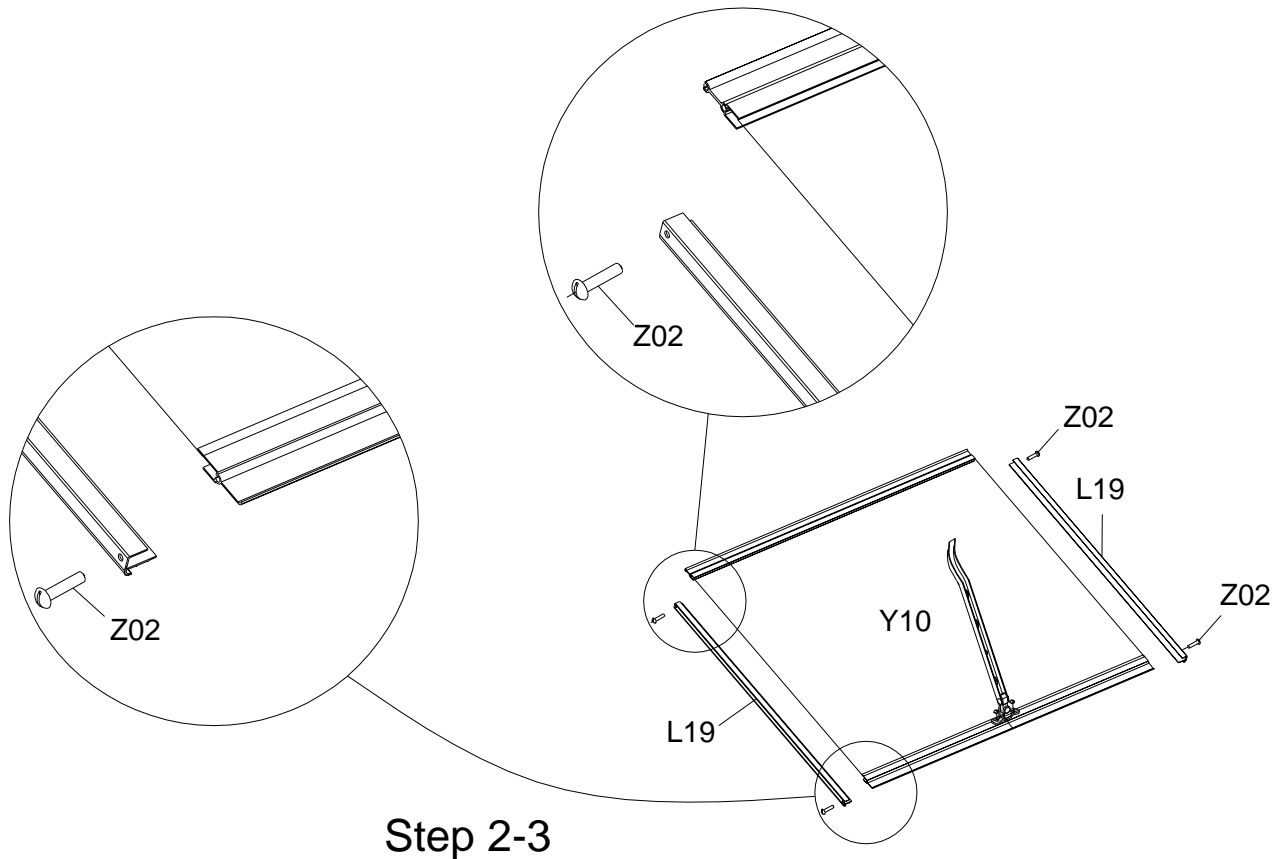



Step 2-1



Step 2-2



Step 2-3

Part	NO.	QTY.
	L01A	1
	L01B	1
	L01C	2
	L03B	4
	L02C	1
	L02D	1
	L02E	1
	L05A	2
	L08A	1
	L09	1

(P5-P7) Back Assembly

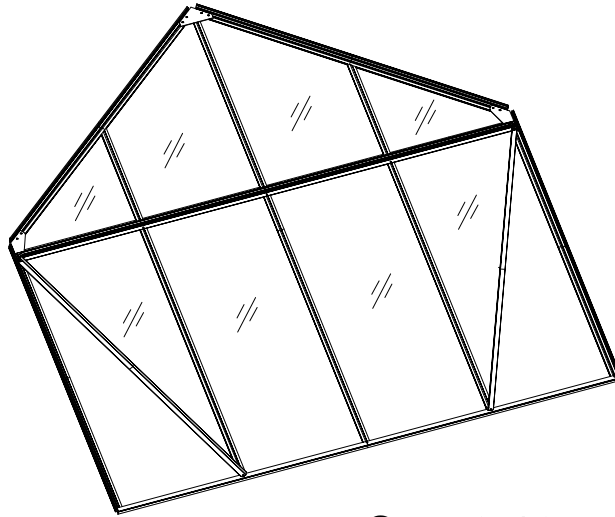

Step 3-10

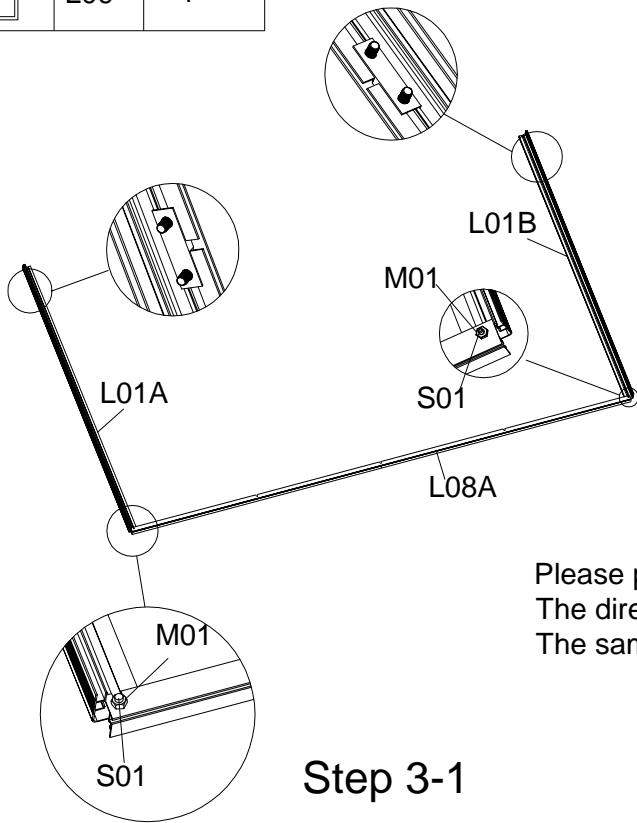

Step 3-1

Please pay attention to the cut corner.
The direction must be correct!!
The same as another side.

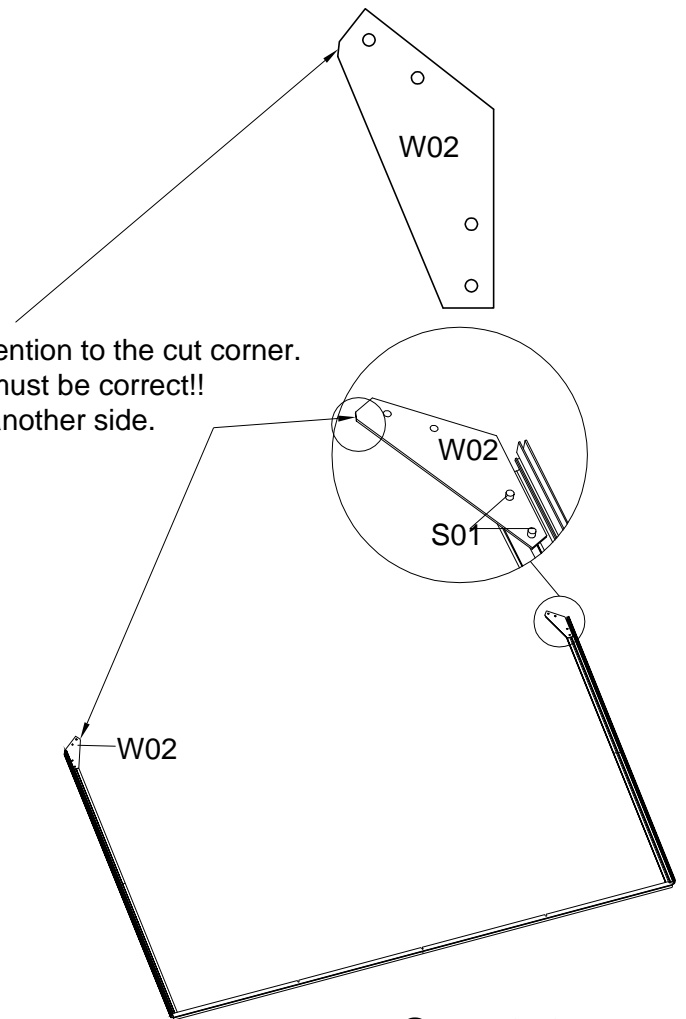

Step 3-2

Please pay attention to the cut corner.
The direction must be correct!!
The same as another side.

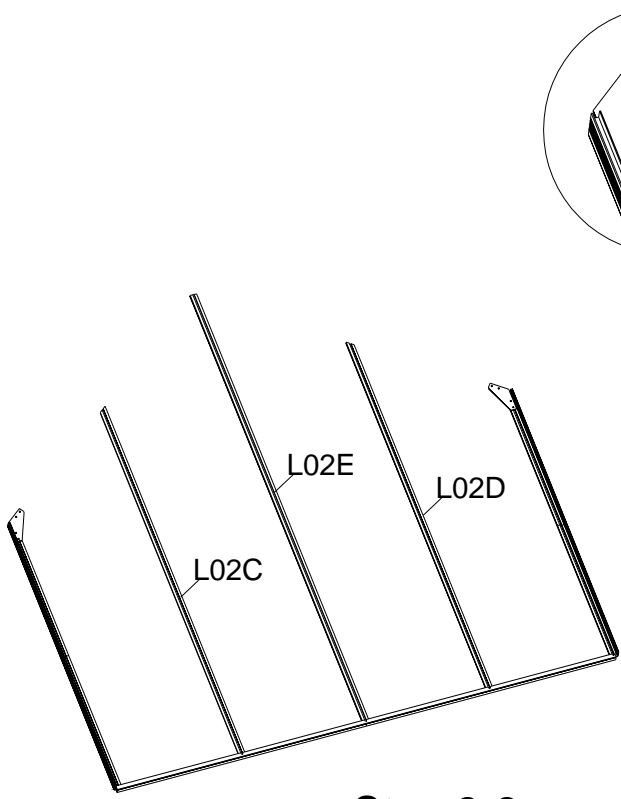

Step 3-3

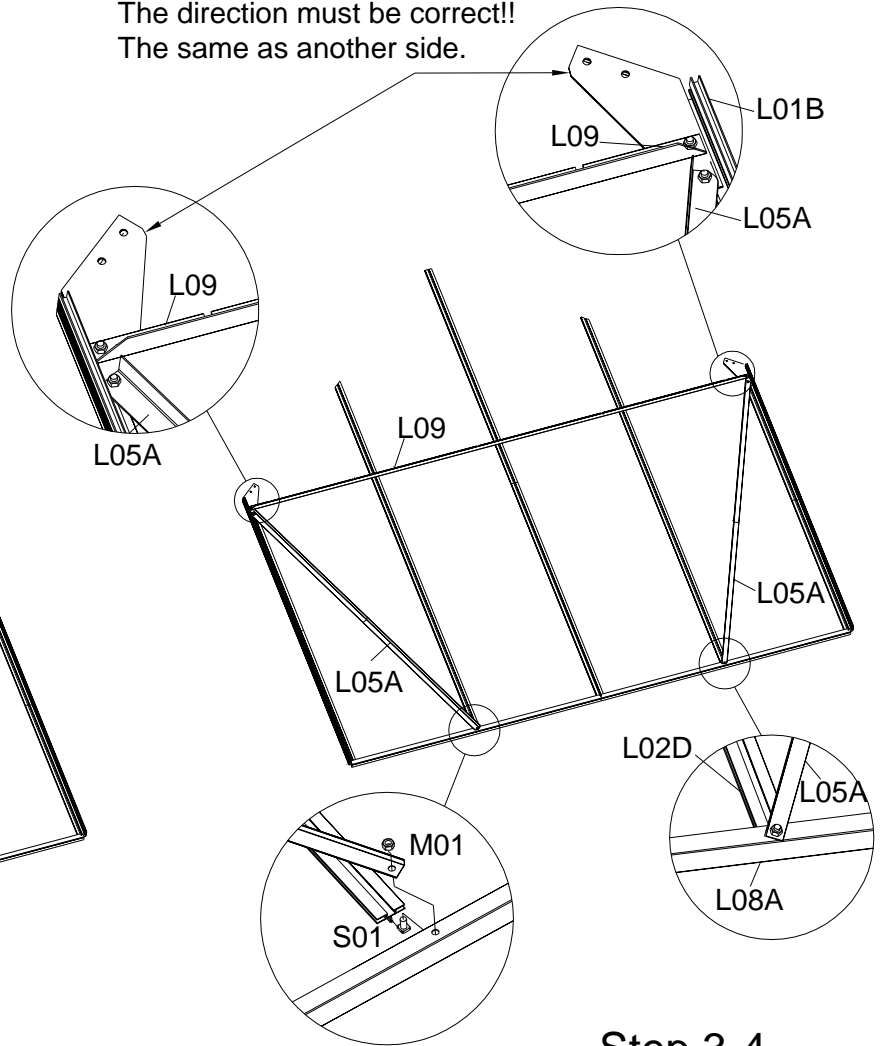

Step 3-4

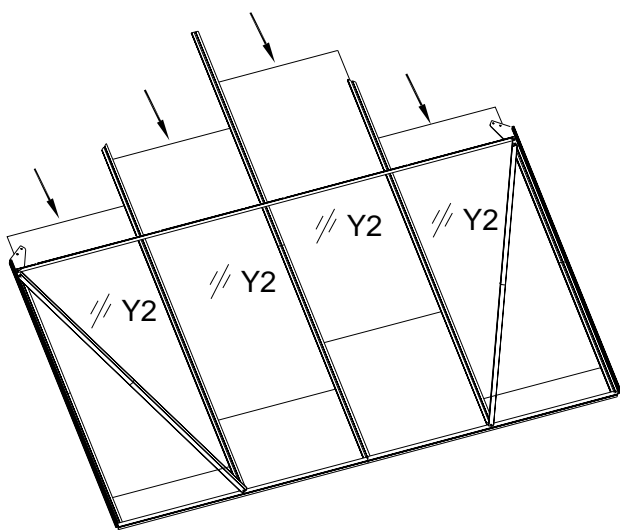

Step 3-5

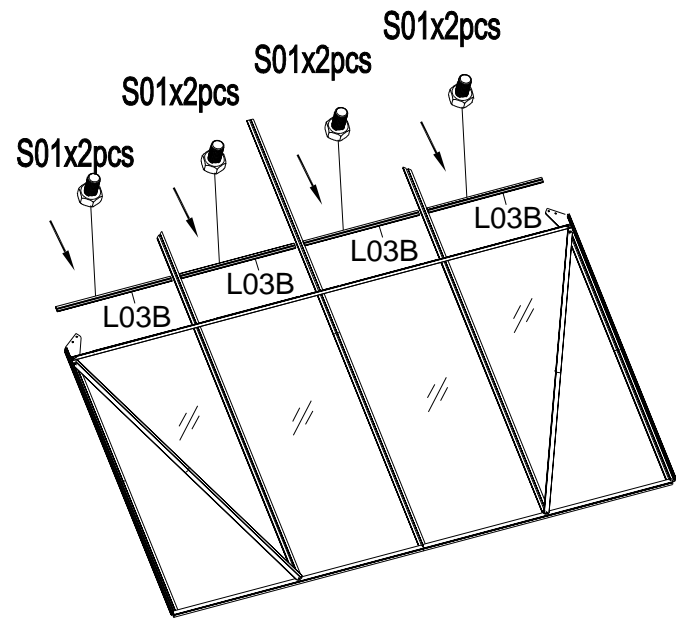

Step 3-6

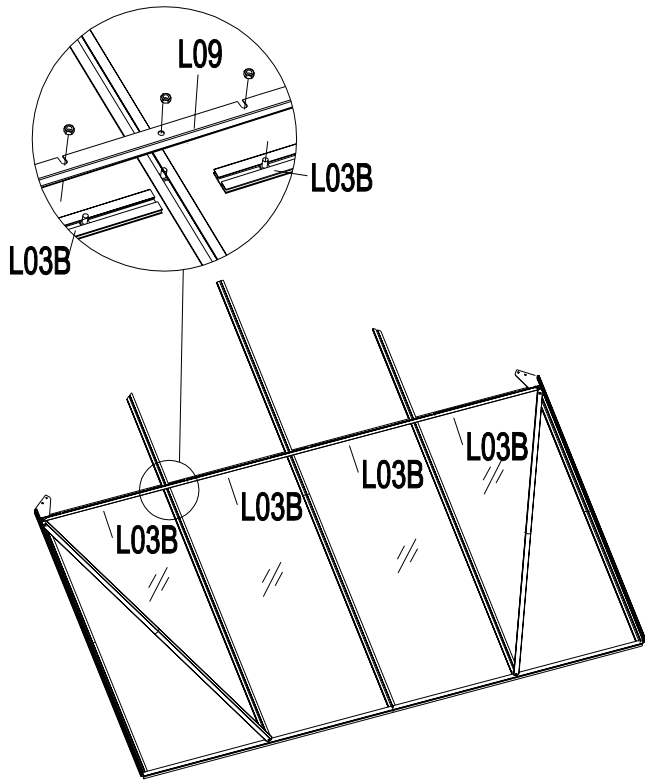

Step 3-7

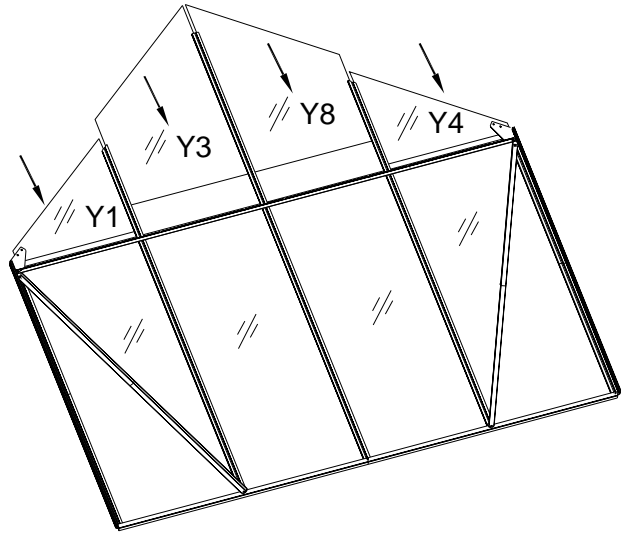

Step 3-8



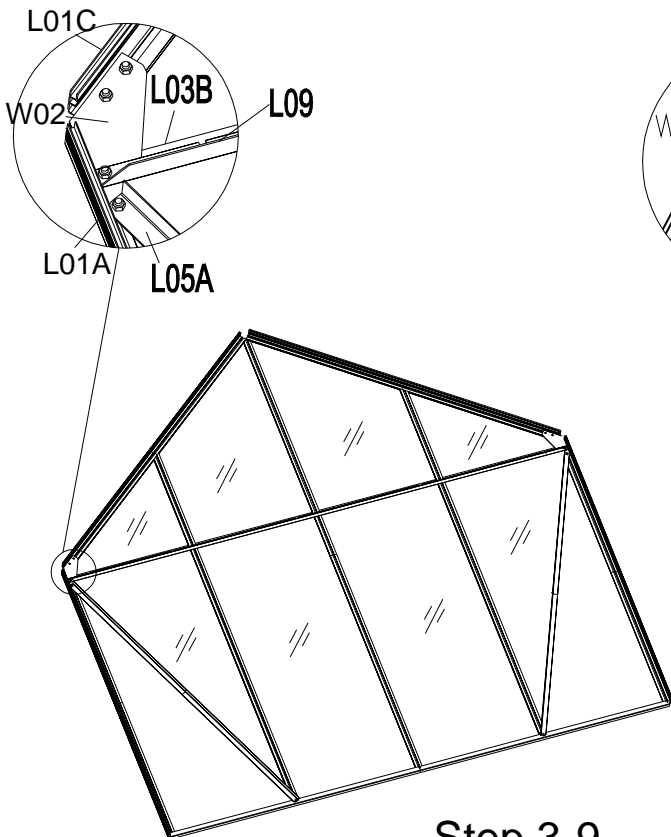



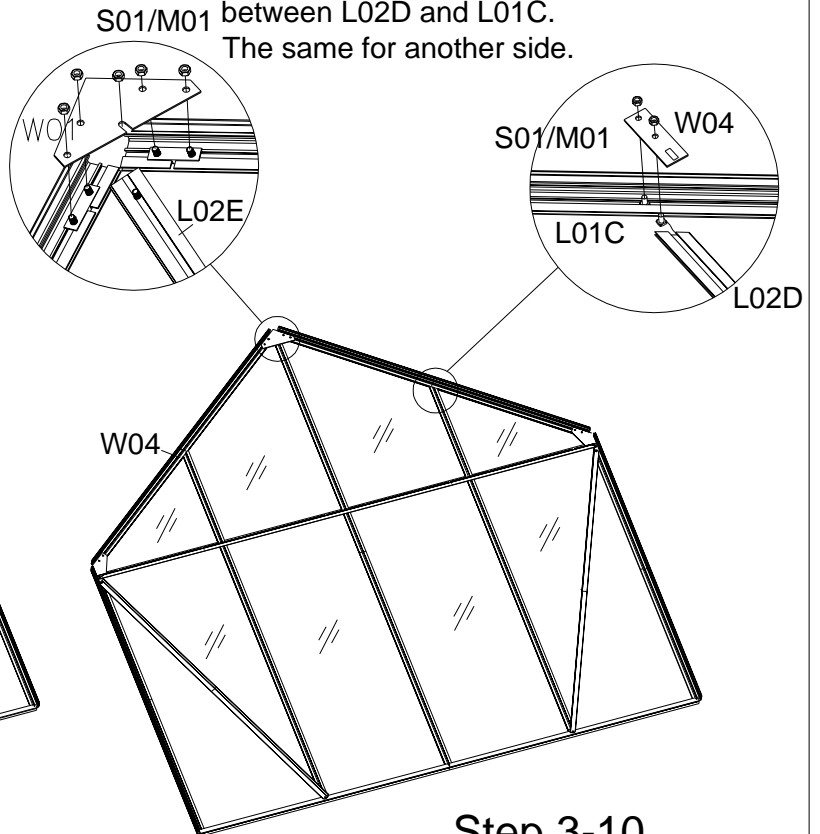





L02D and L01C must be put tightly and correctly using W04. Do not leave big space between L02D and L01C. The same for another side.



Step 3-9



Step 3-10

Part	NO.	QTY.
	L01A	1
	L01B	1
	L01D	1
	L01E	1
	L03A	1
	L03B	2
	L03T	1
	L04A	1
	L04B	1
	L05A	2
	L05B	2
	L10	1
	L14	1

(P8-P11)Front Assembly

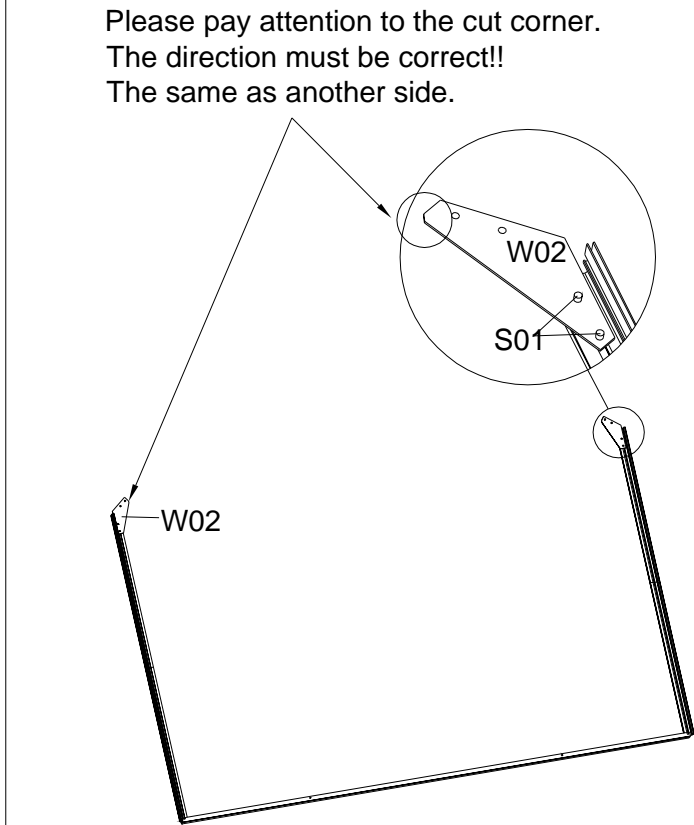
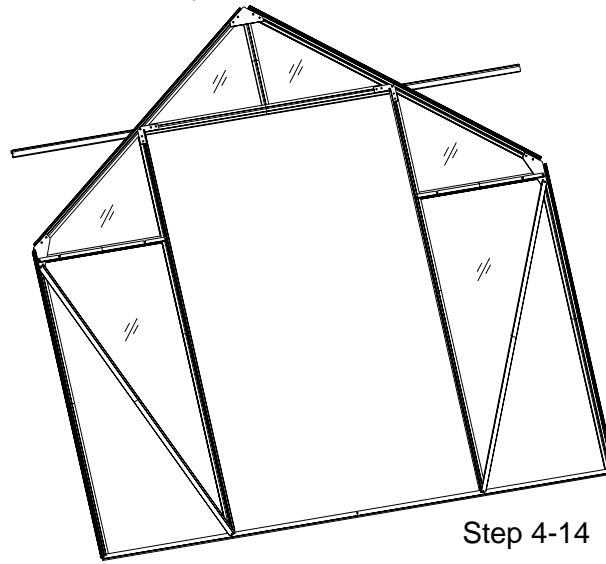

Step 4-2

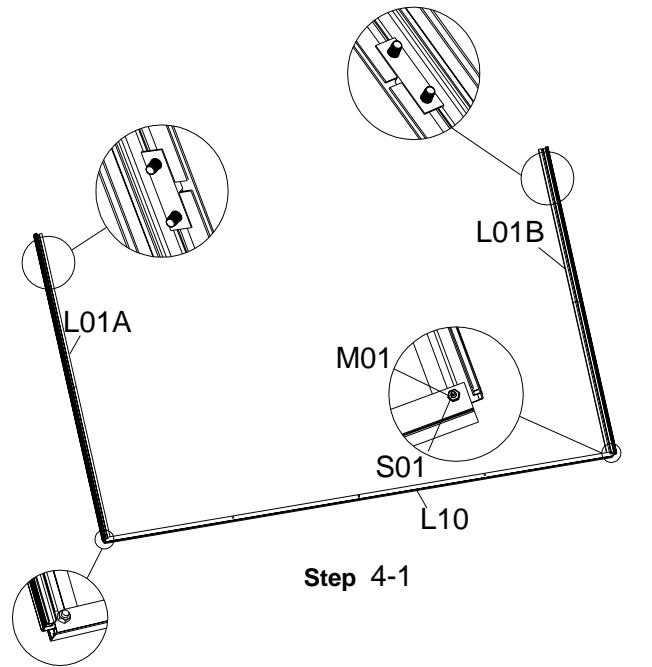

Step 4-1

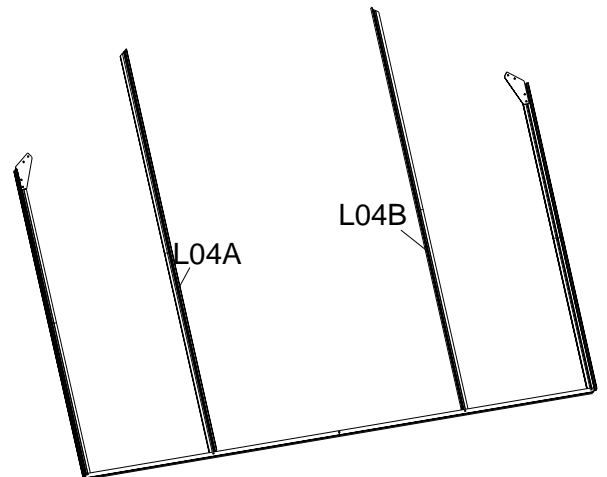

Step4-3

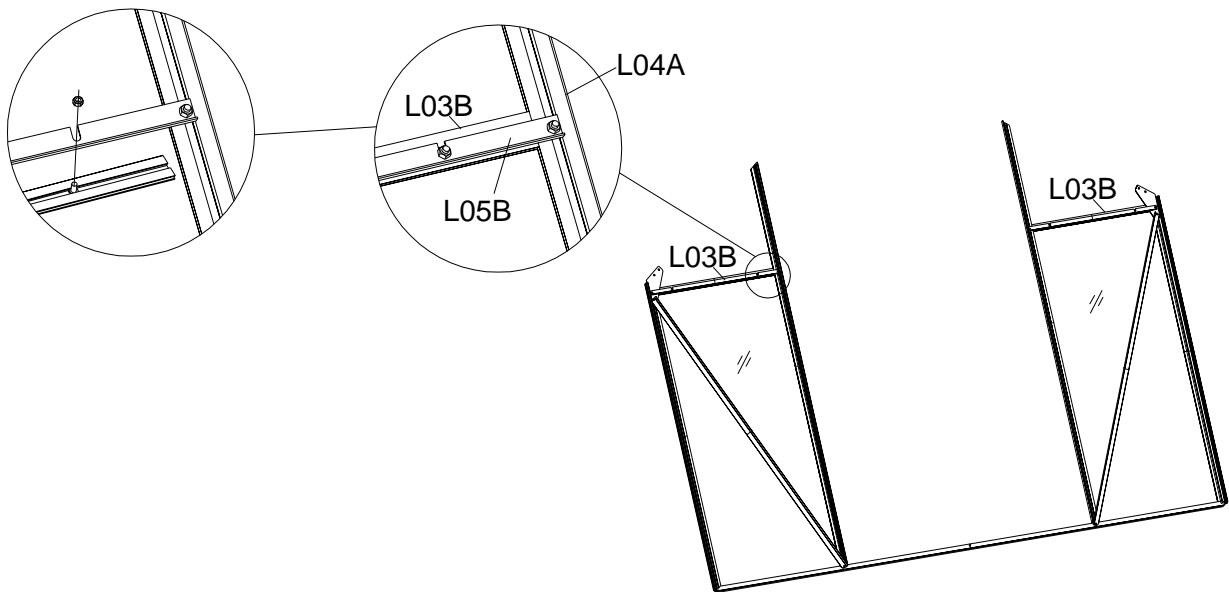
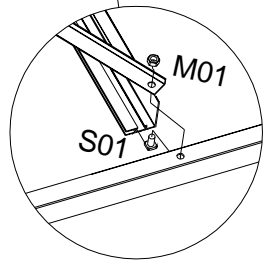
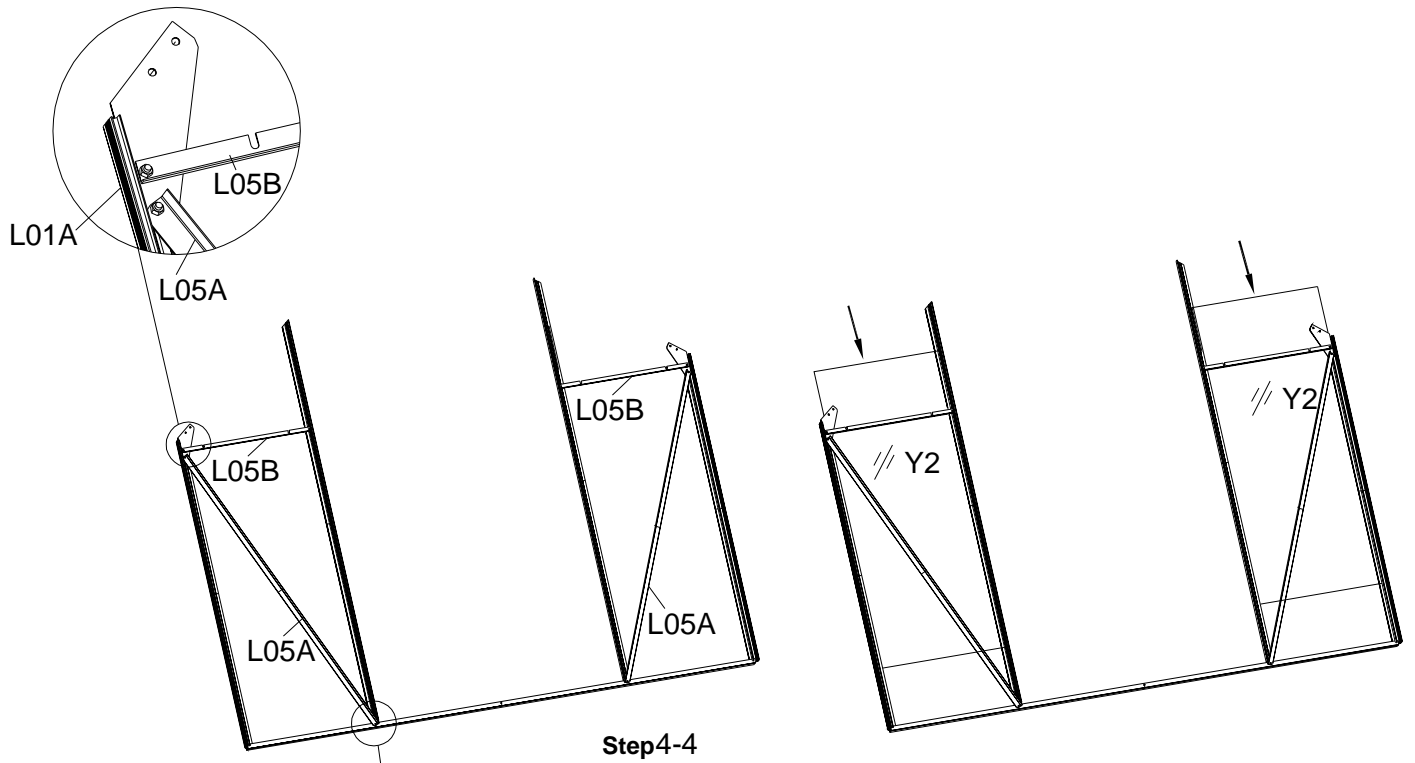

Step 4-6

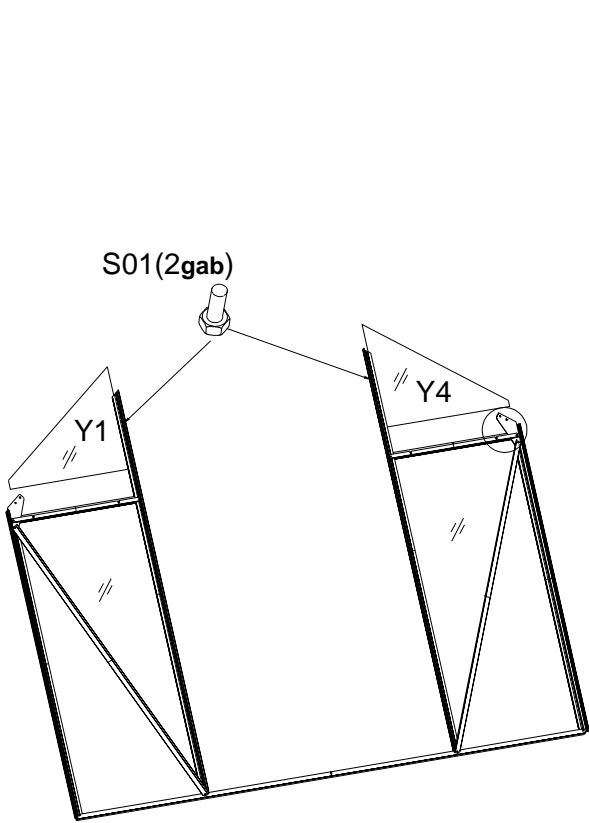

Step4-7

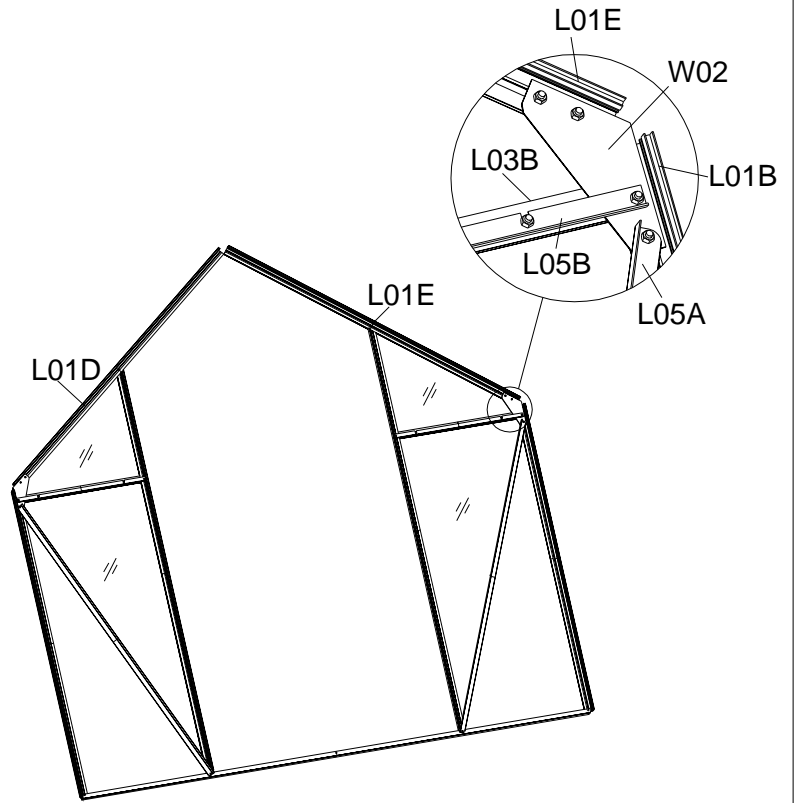

Step 4-8

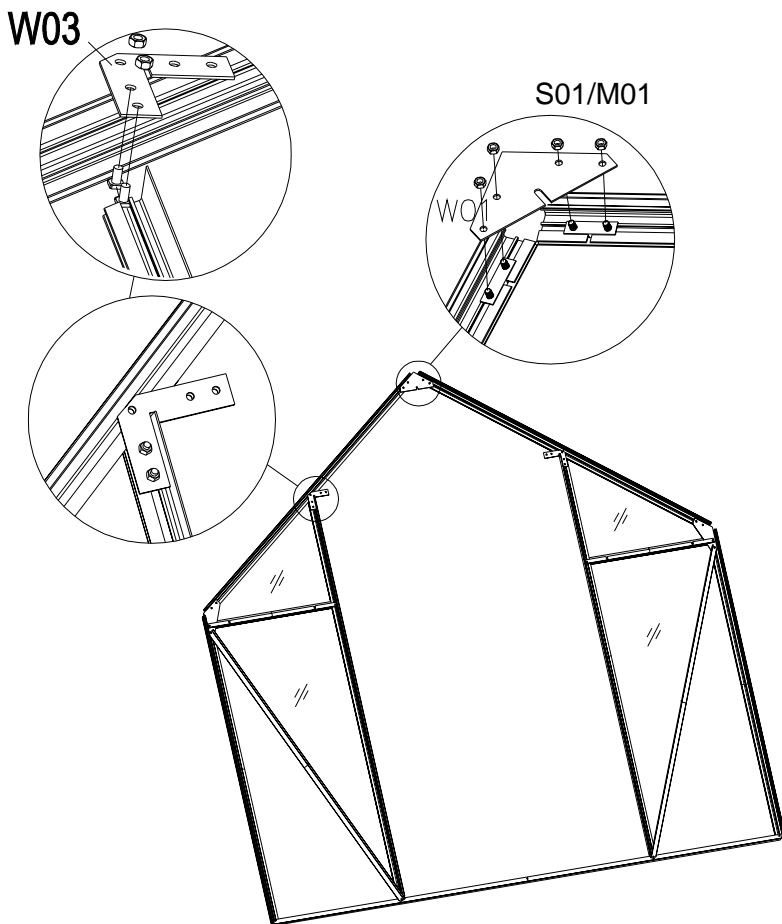

Step 4-9

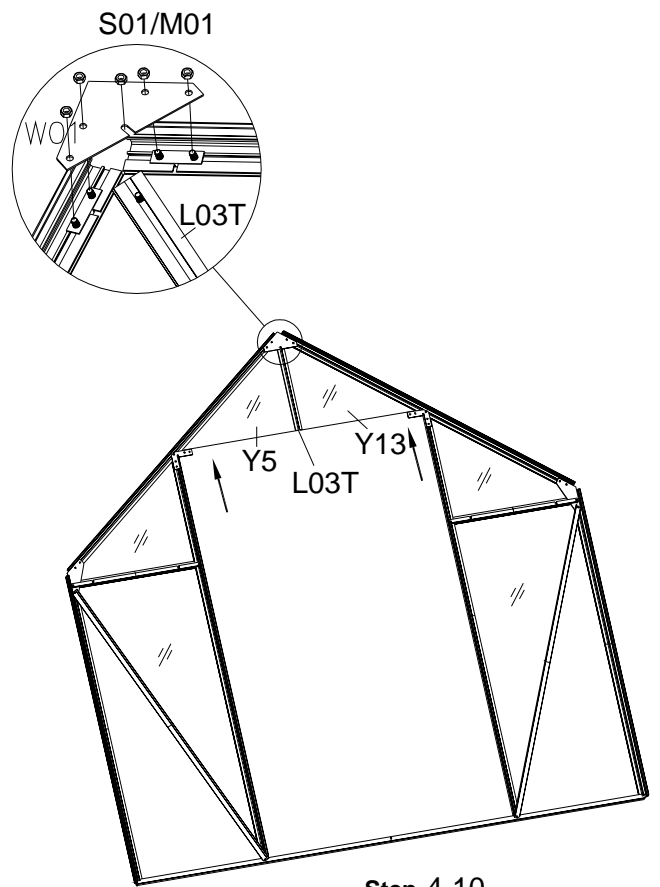

Step 4-10

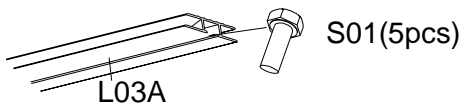

Step 4-11

M01/S01

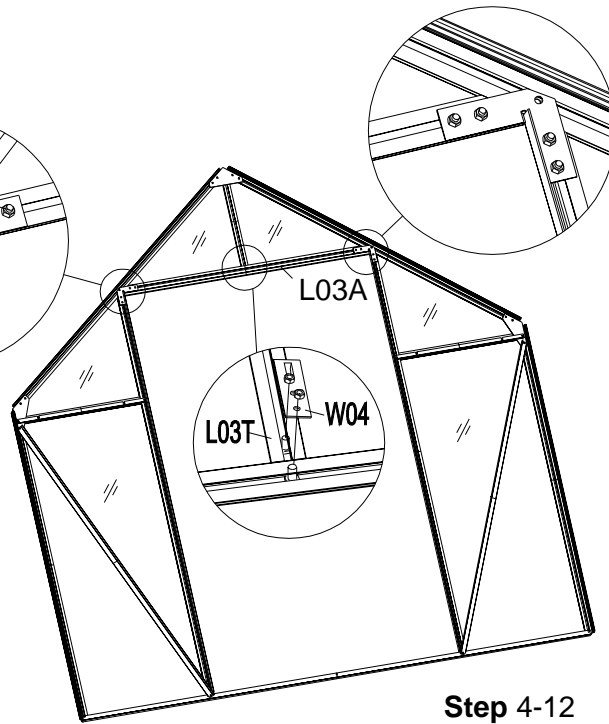
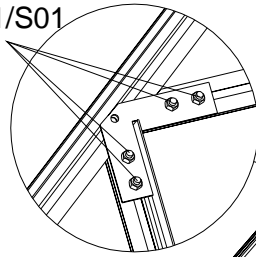

Step 4-12

Use S02 and M01 to fix the W03's position correctly.

! S02(2pcs)

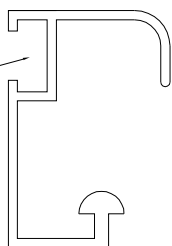

L14

Step 4-13

S02/M01

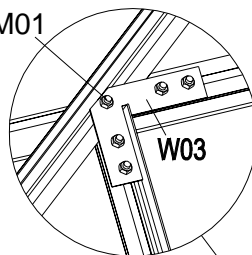

W03



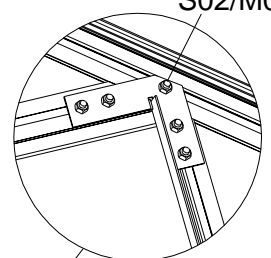



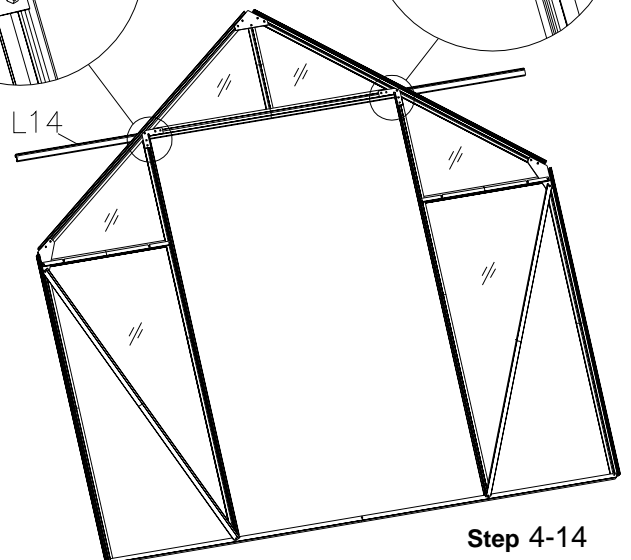



L14



S02/M01



Step 4-14

Part	NO.	QTY.
	L02A	10
	L02B	10
	L03B	4
	L05C	4
	L05D	4
	L05E	5
	L05F	10
	L06	1
	L07	2
	L08B	2

(P12-P23)Assembly

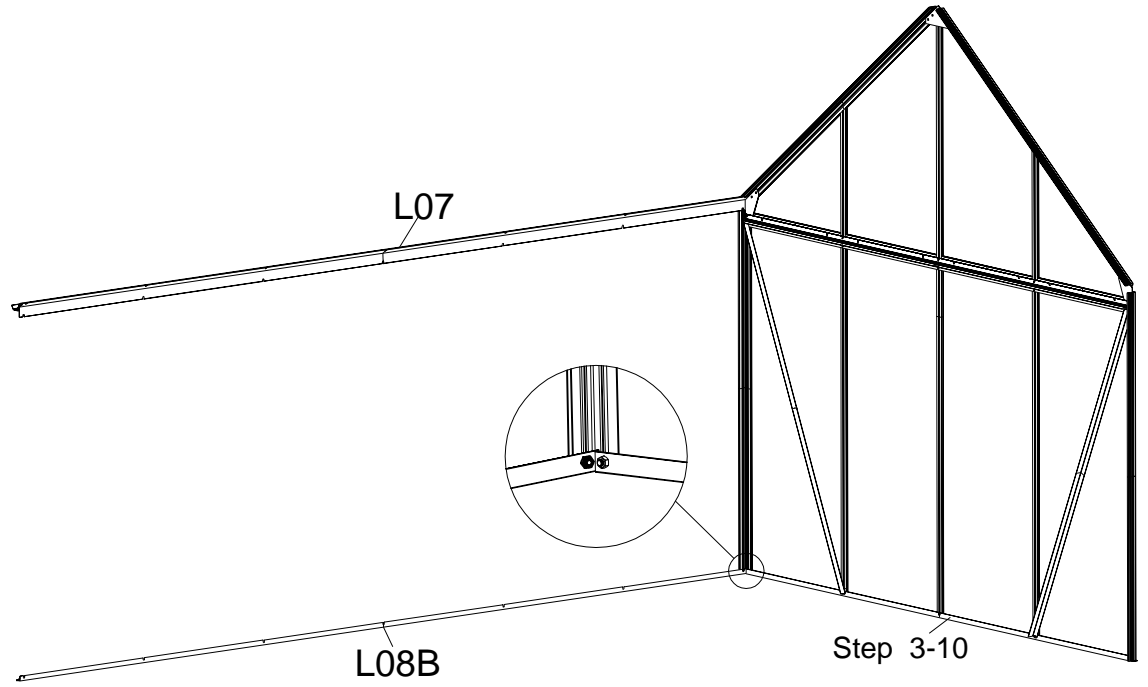

Step 5

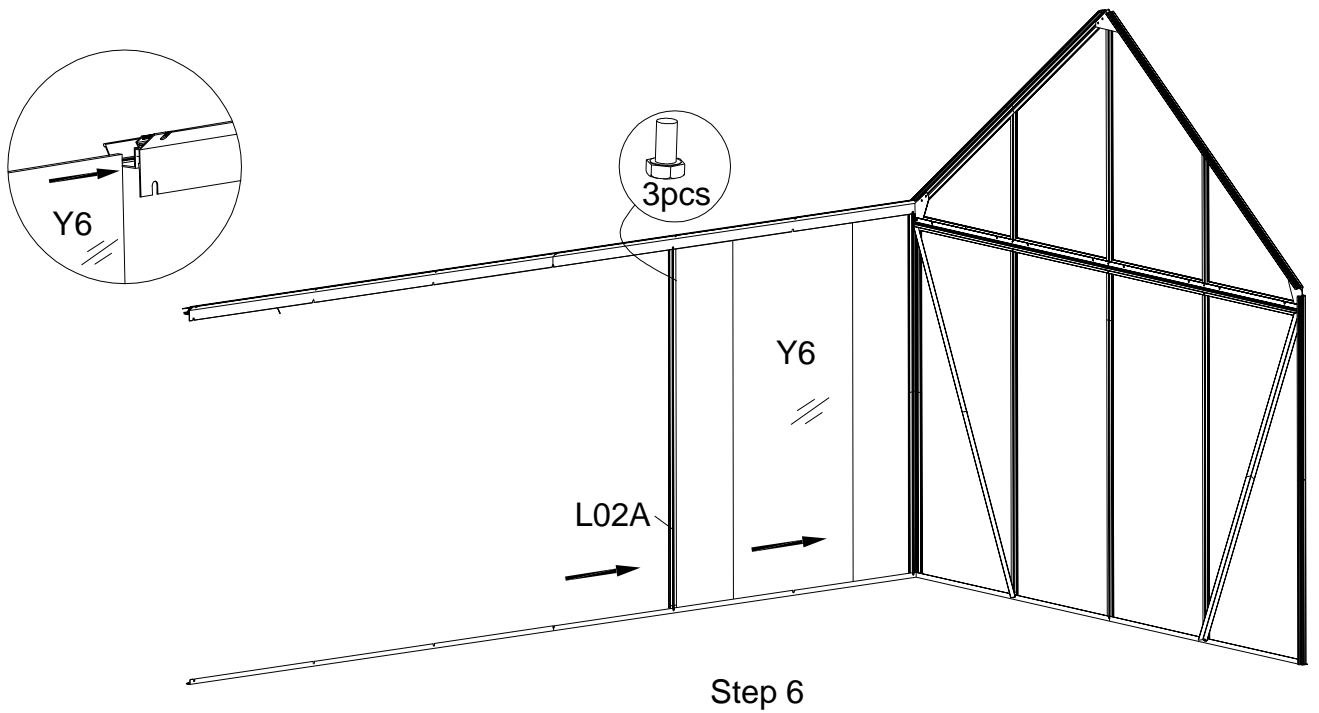

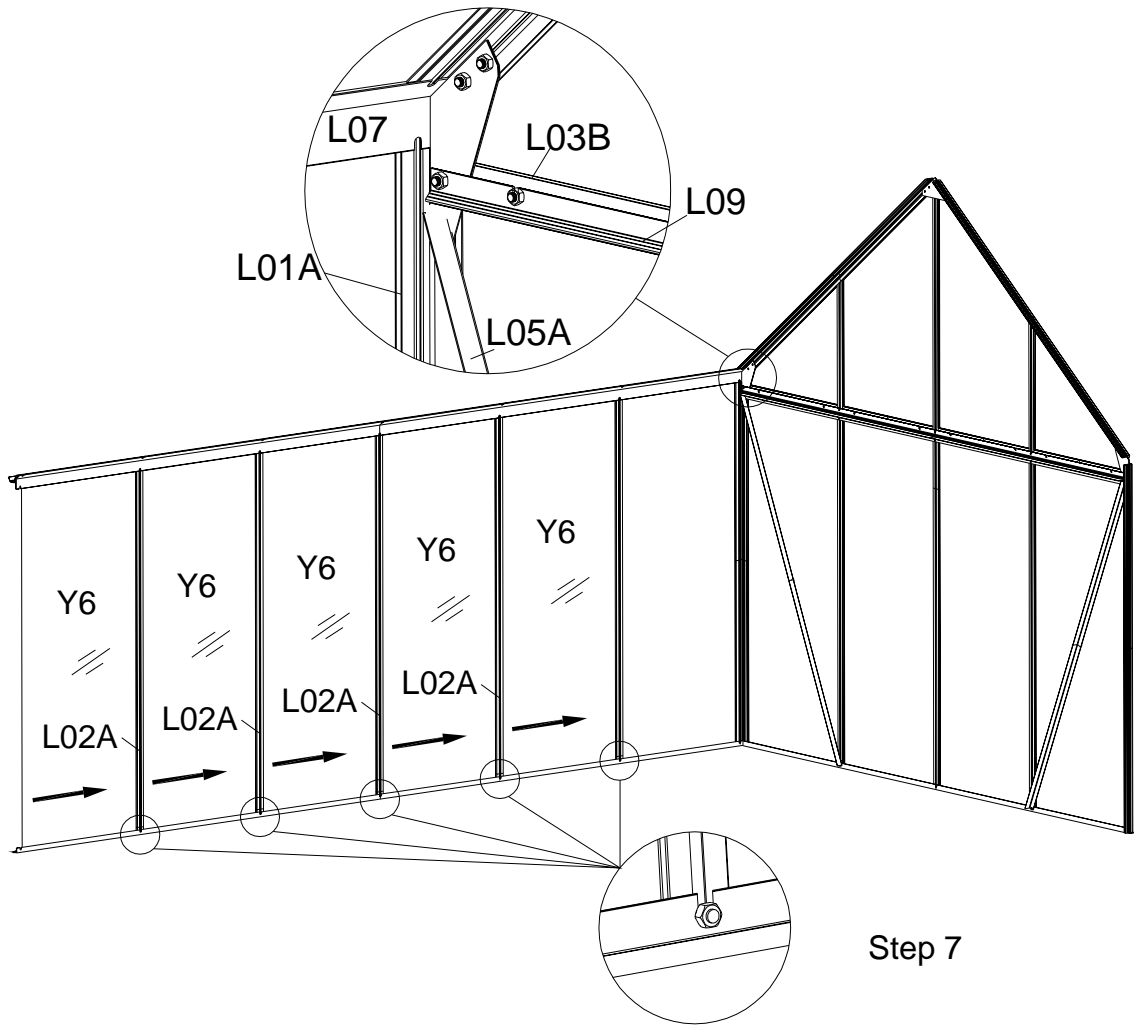

Step 7

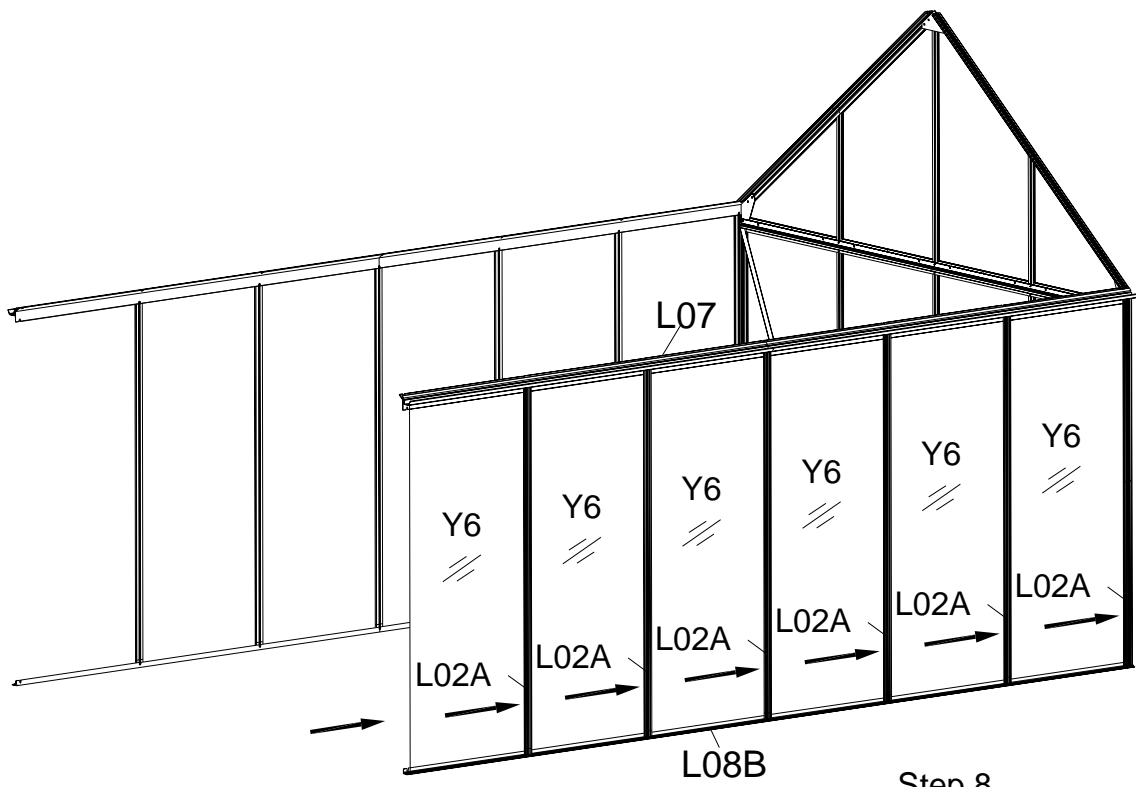

Step 8

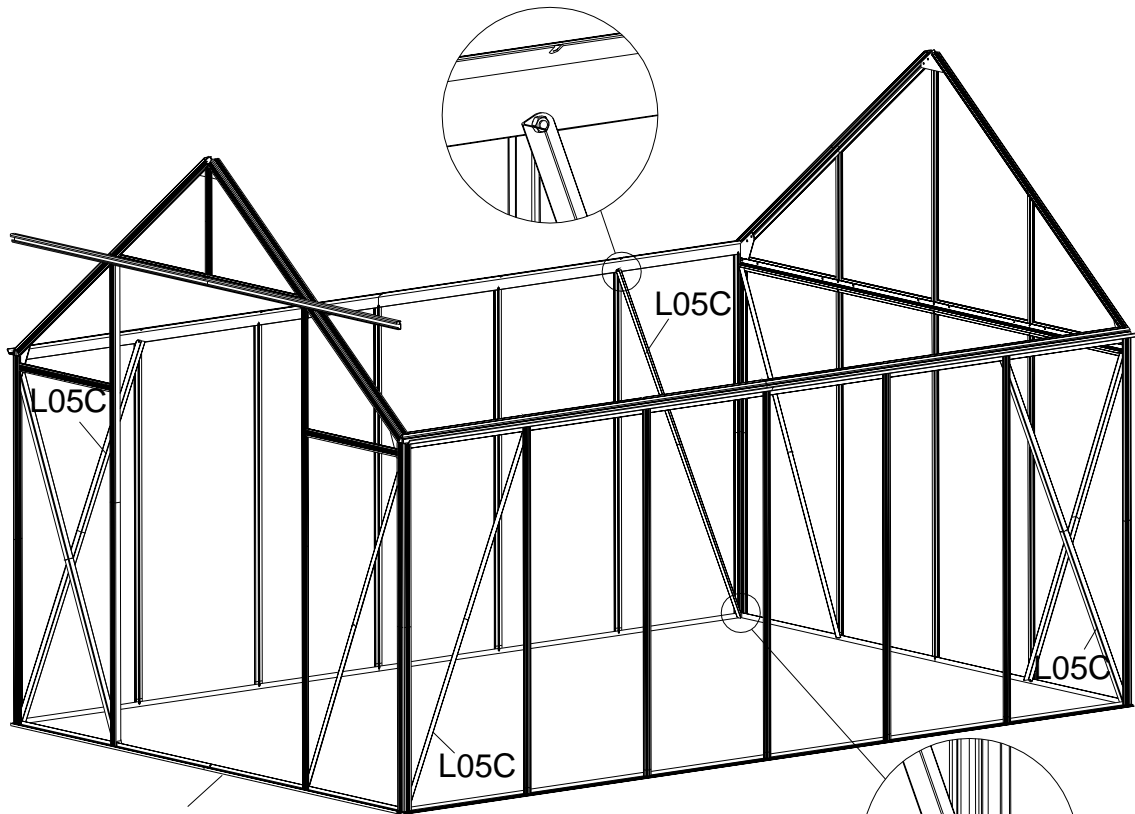

Step 4-14

Step 9

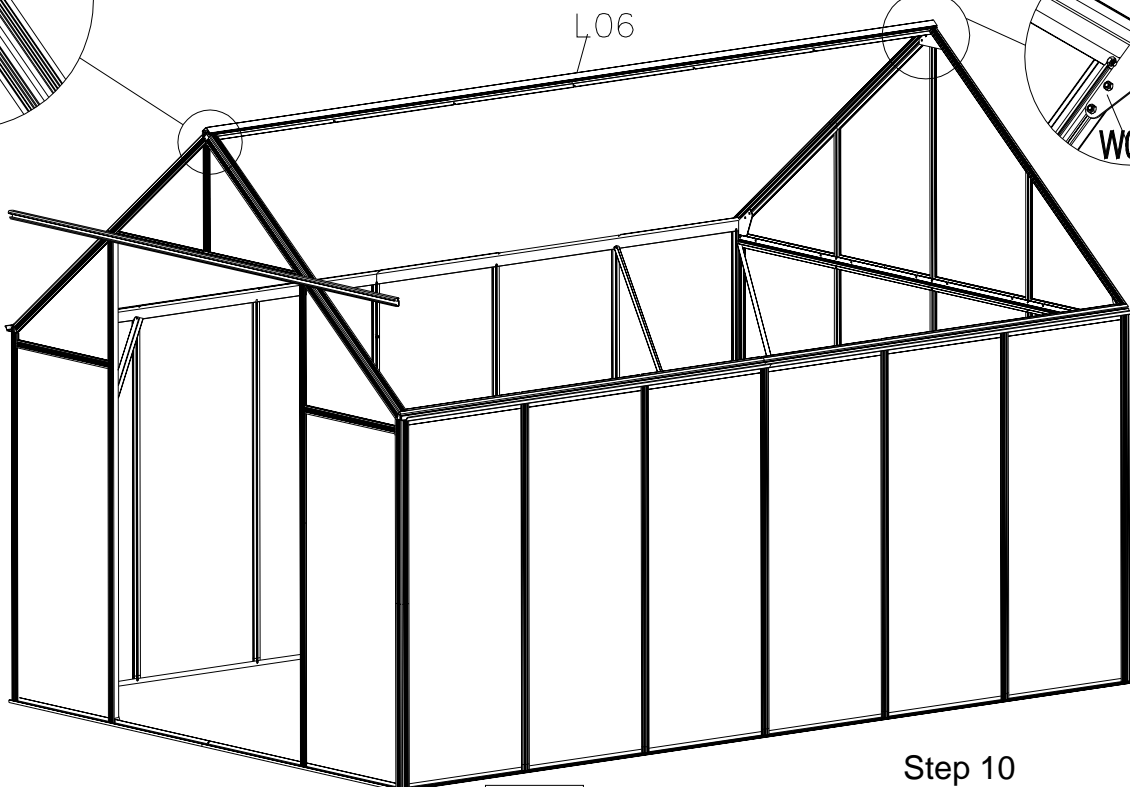
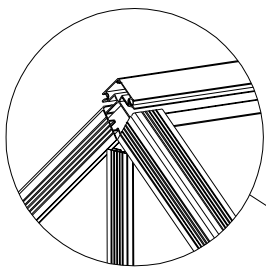

L06

W01

Step 10

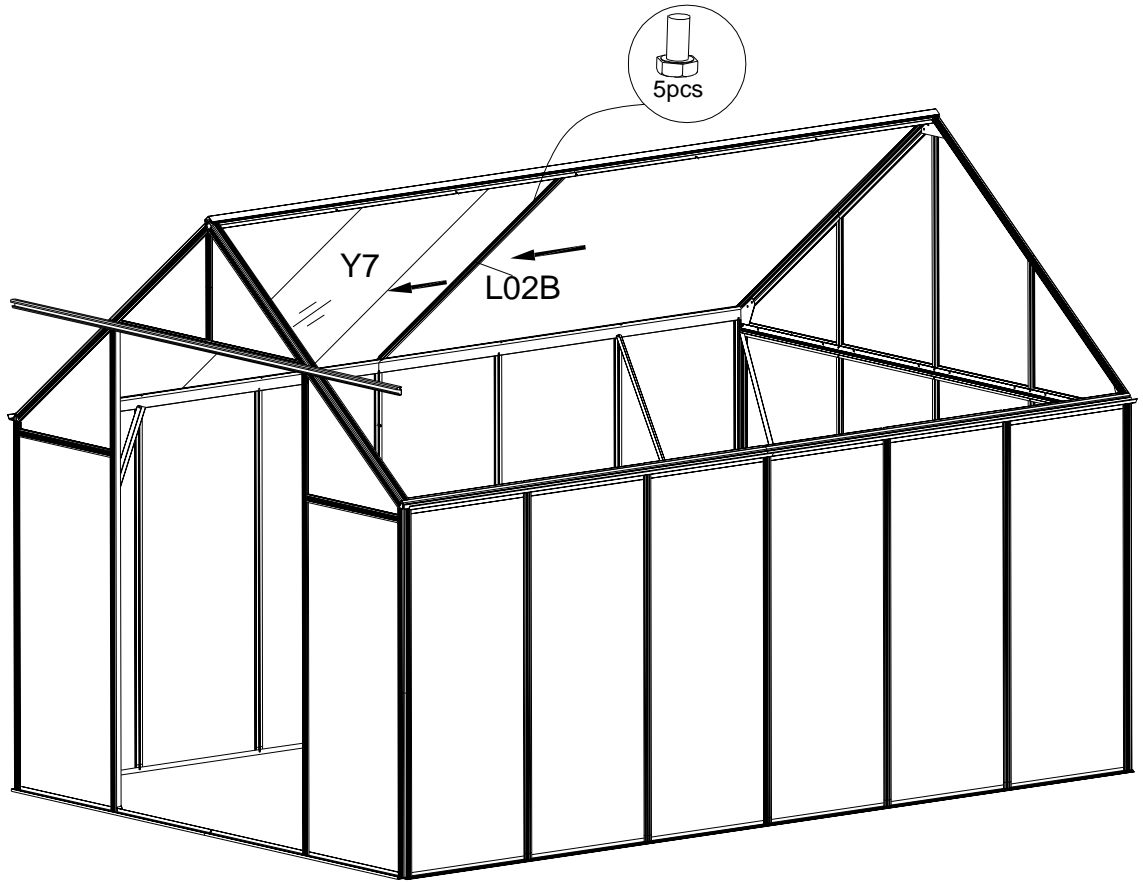

Step 11

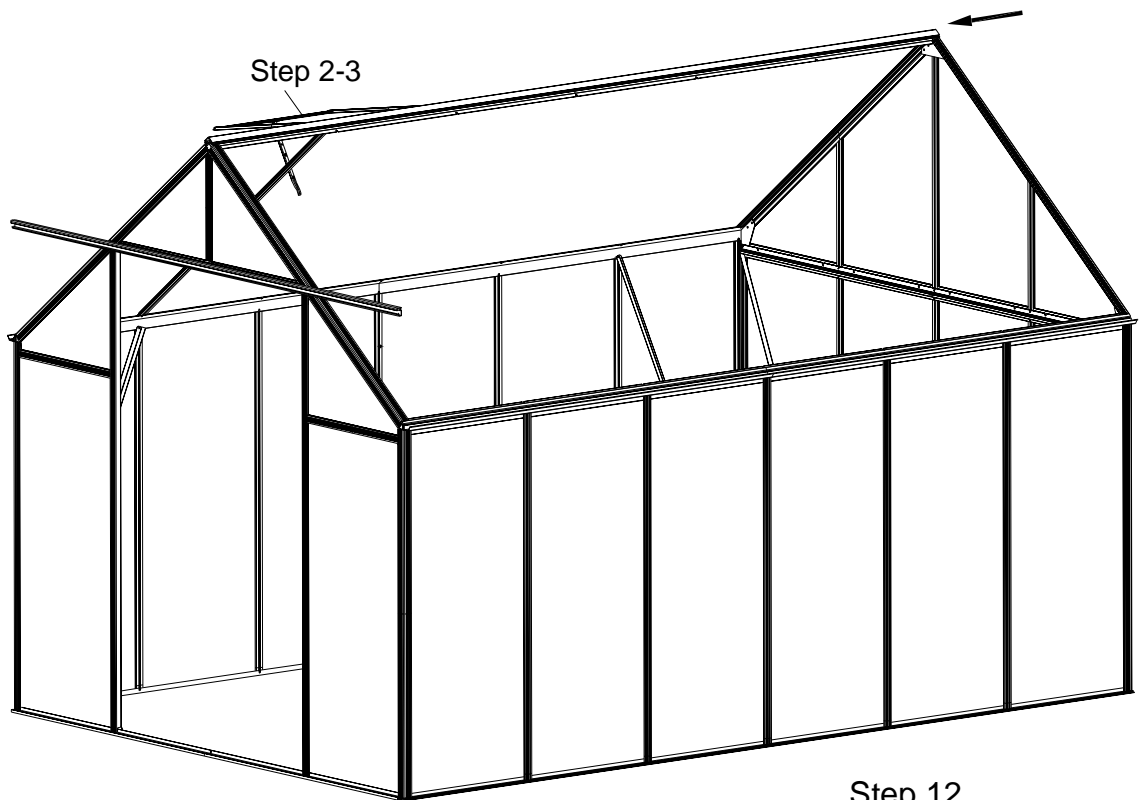

Step 12

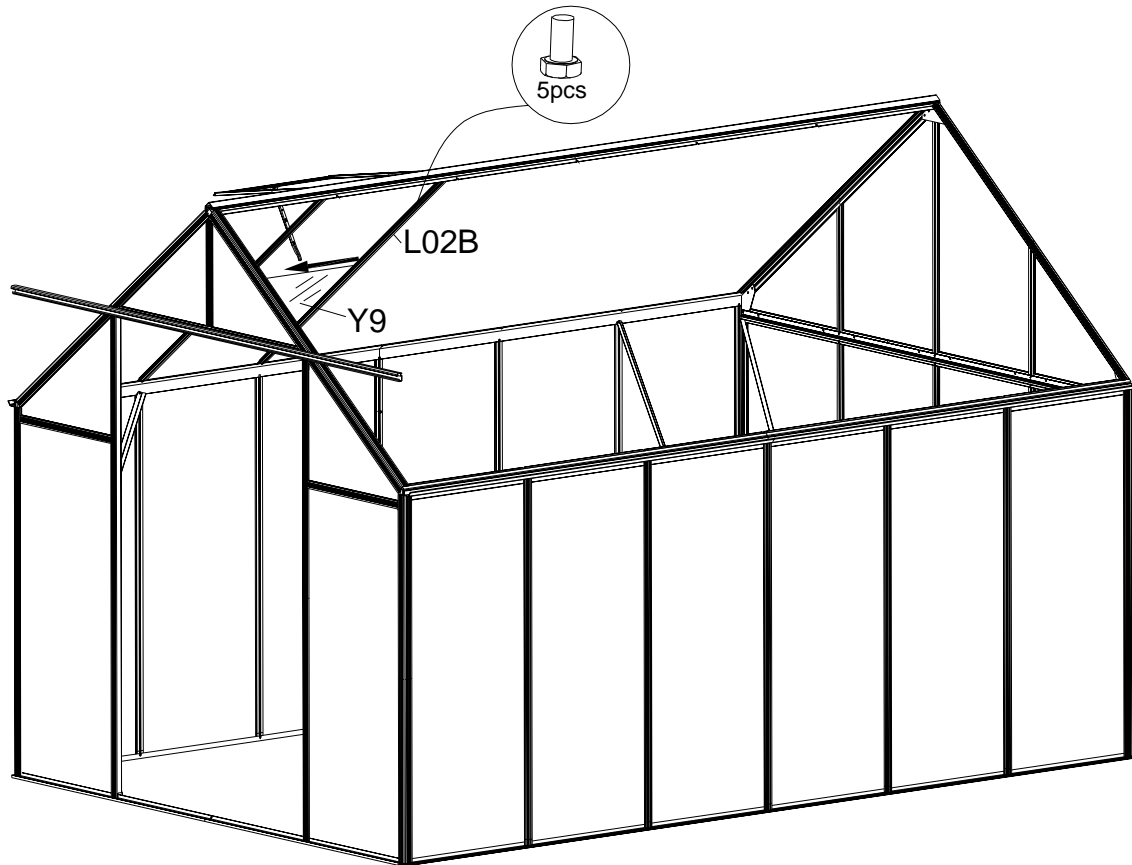

Step 13

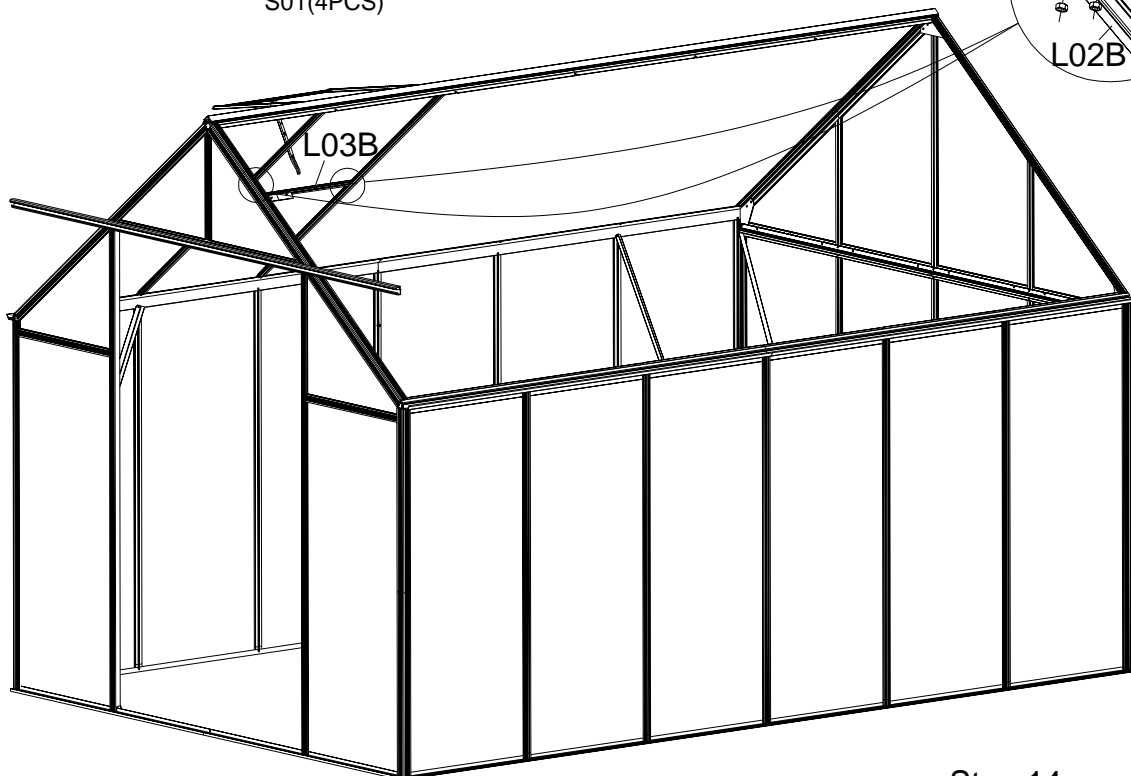

Step 14

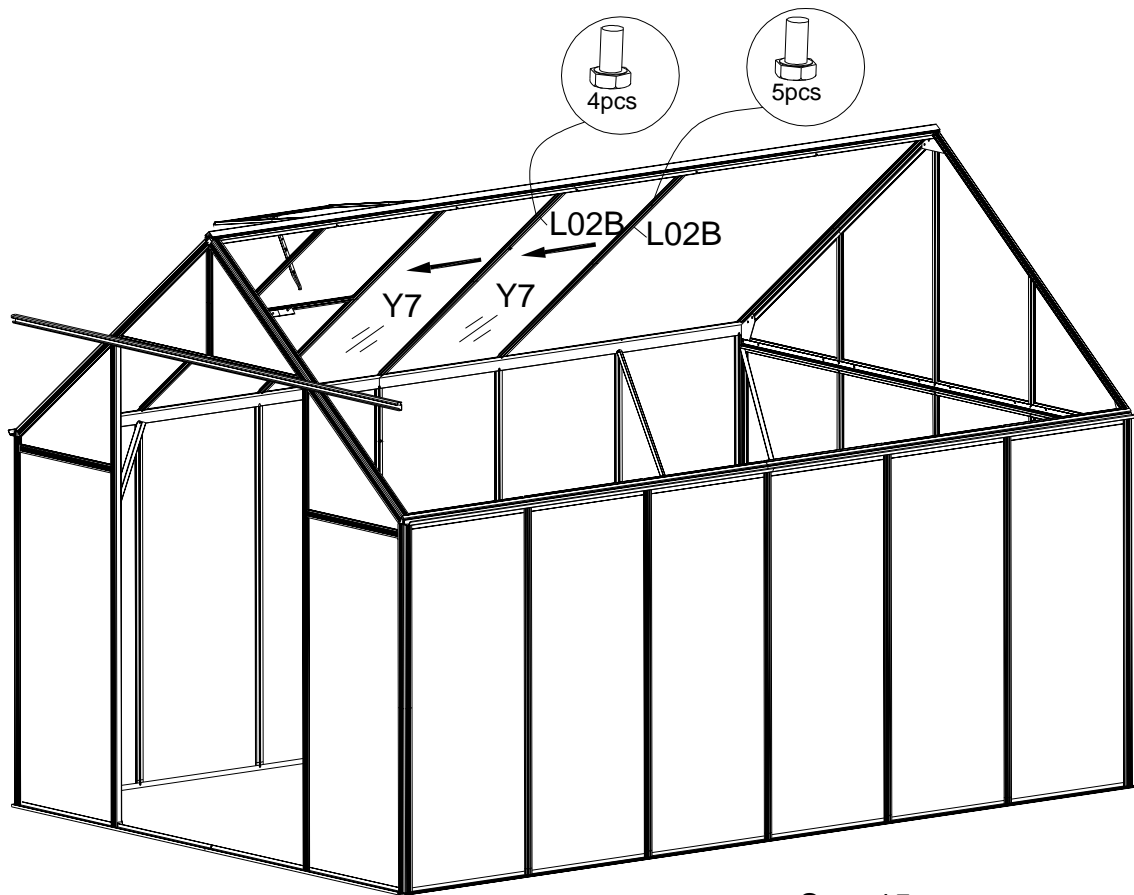

Step 15

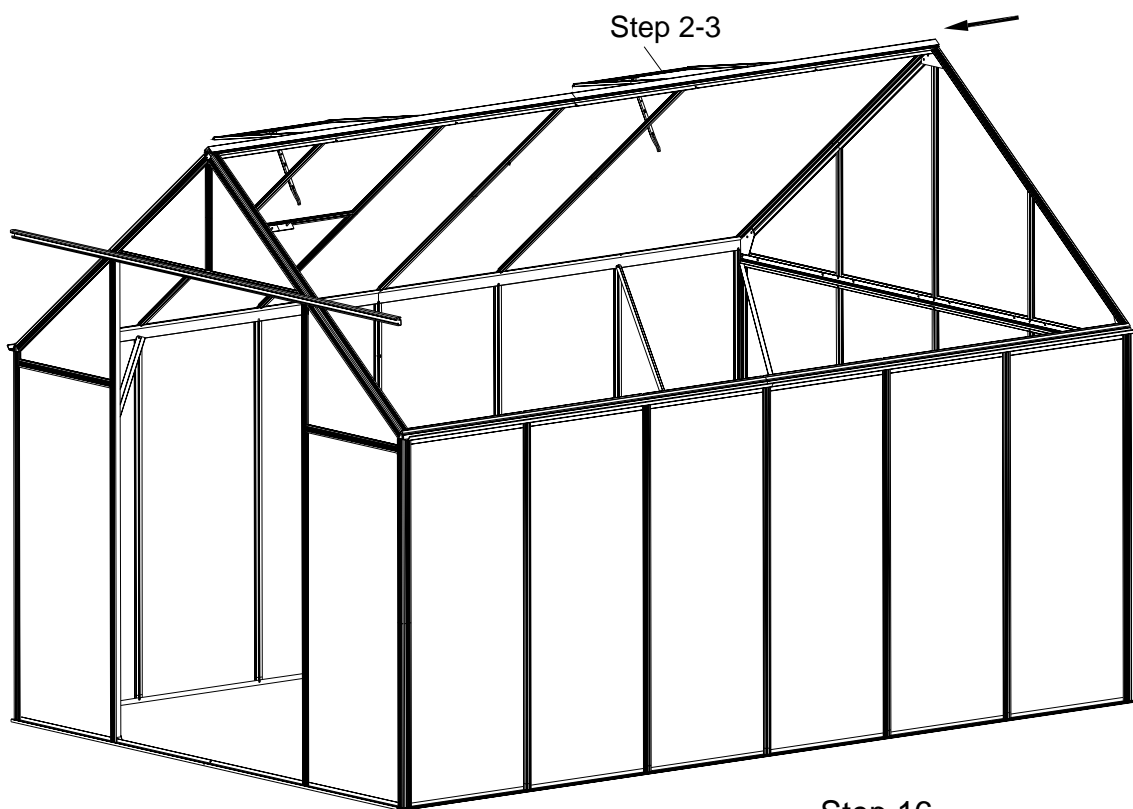

Step 16

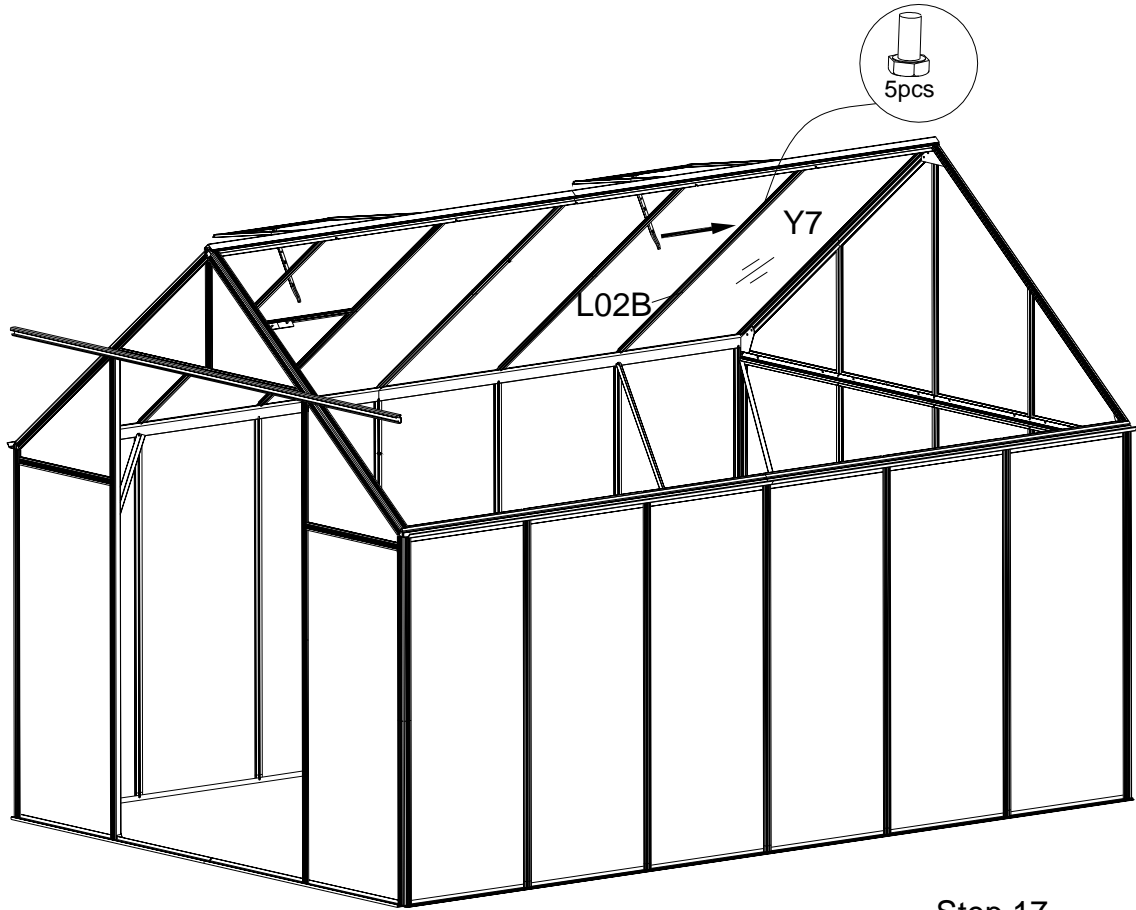

Step 17

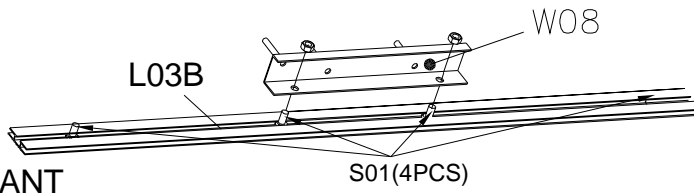

IMPORTANT

Y9 is the last piece of polycarbonate to go in. Slide L03B up. Once Y9 is in position slide over Y9 to lock it in place. Gently bend the sheet to pop it into the extrusion

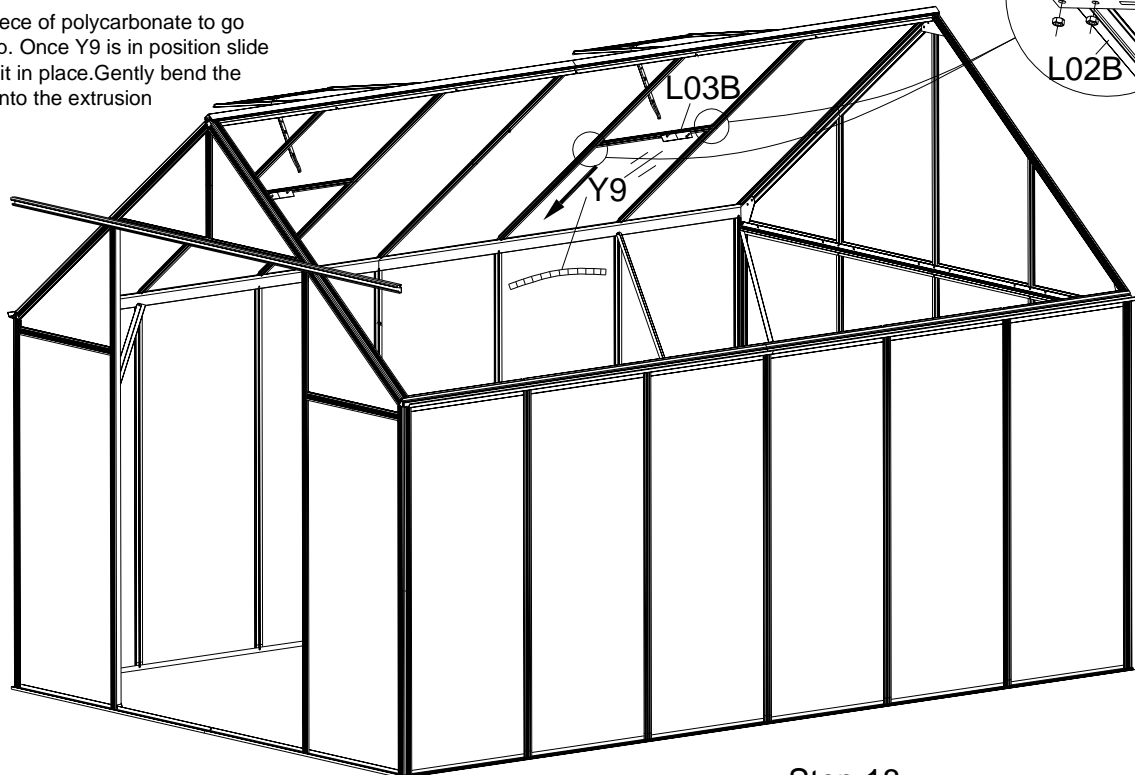
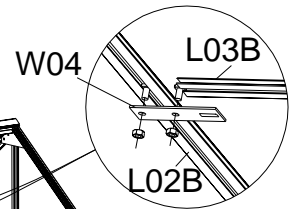

Step 18

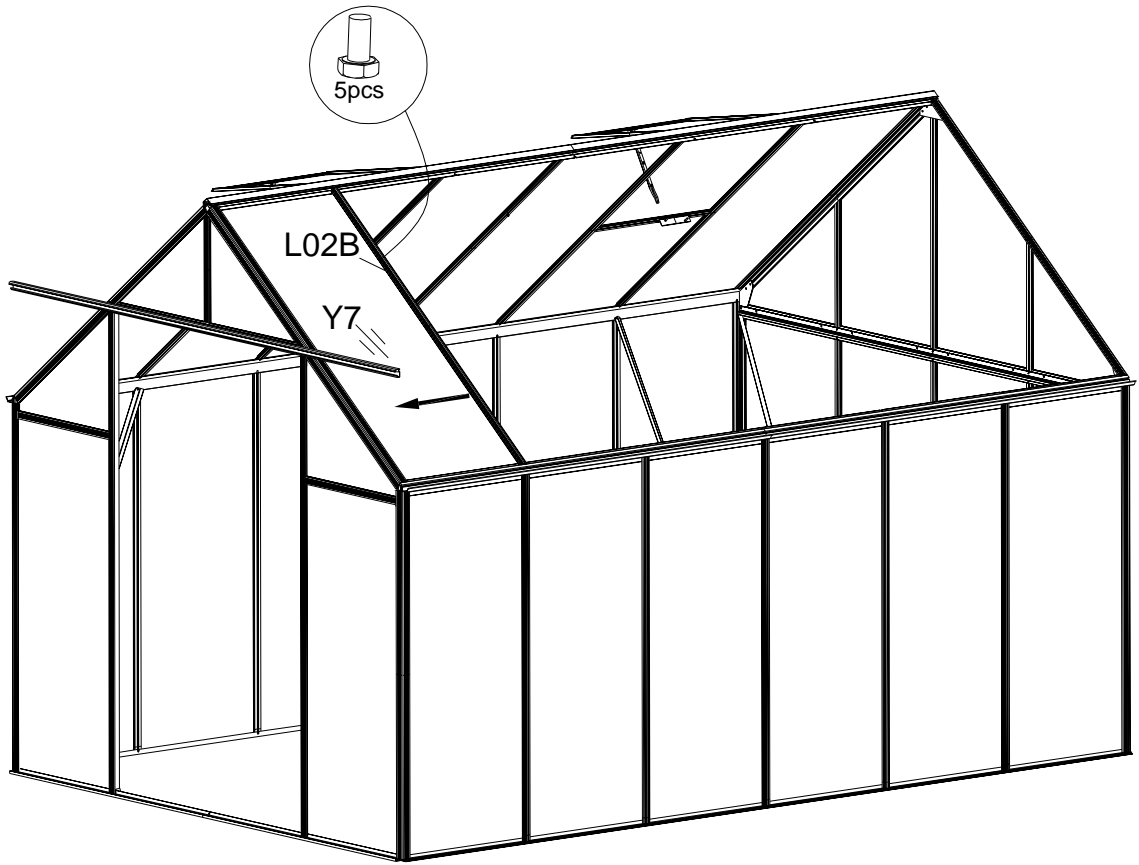

Step 19

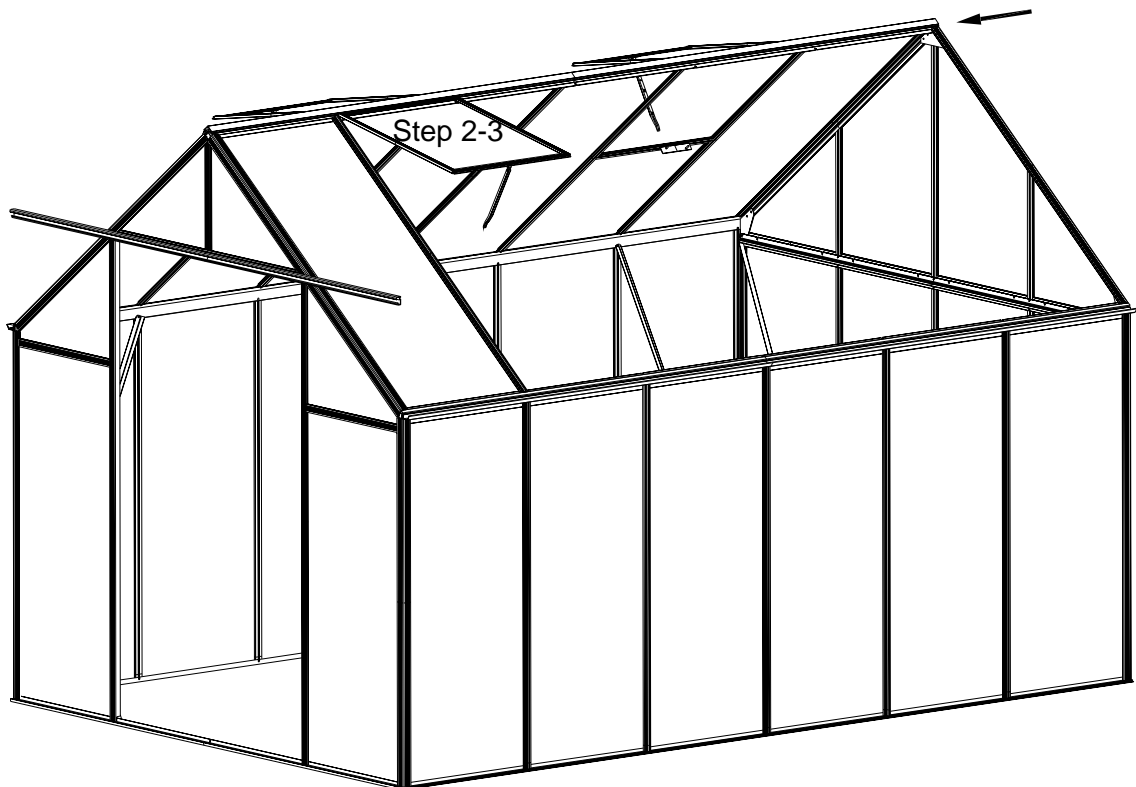

Step 20

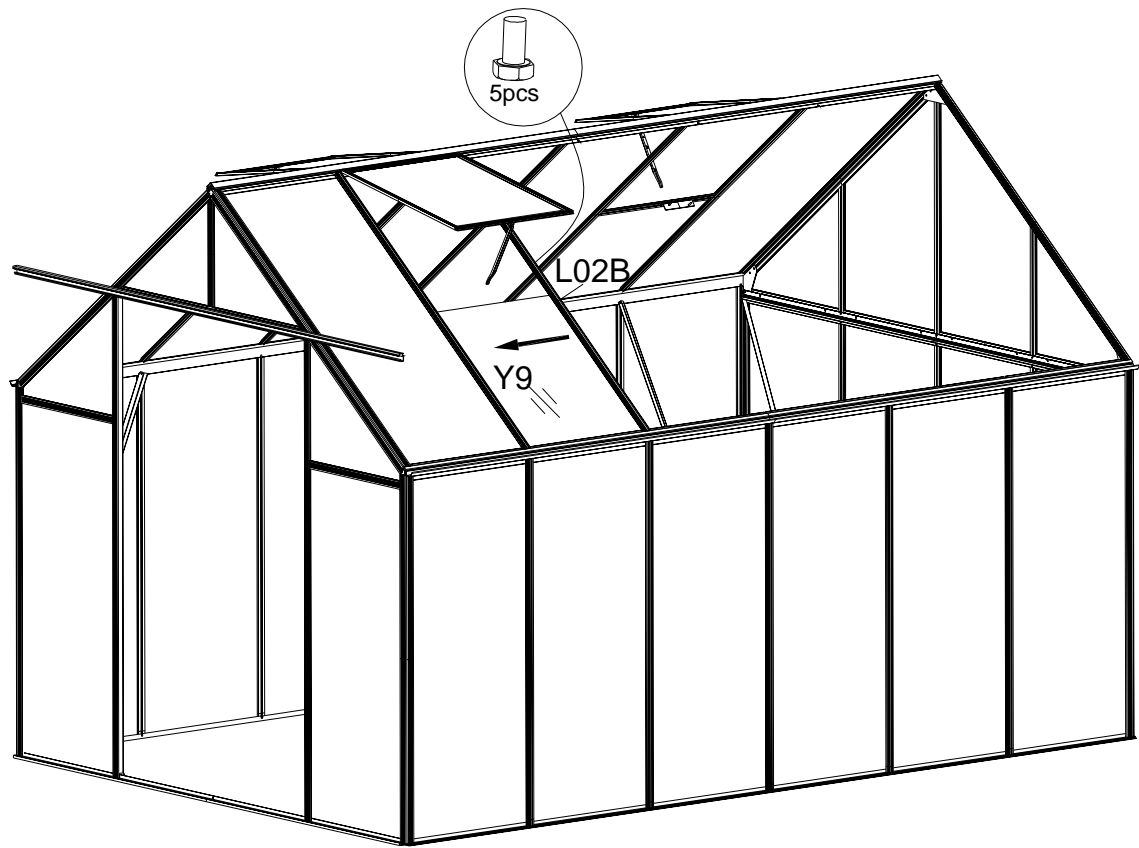

Step 21

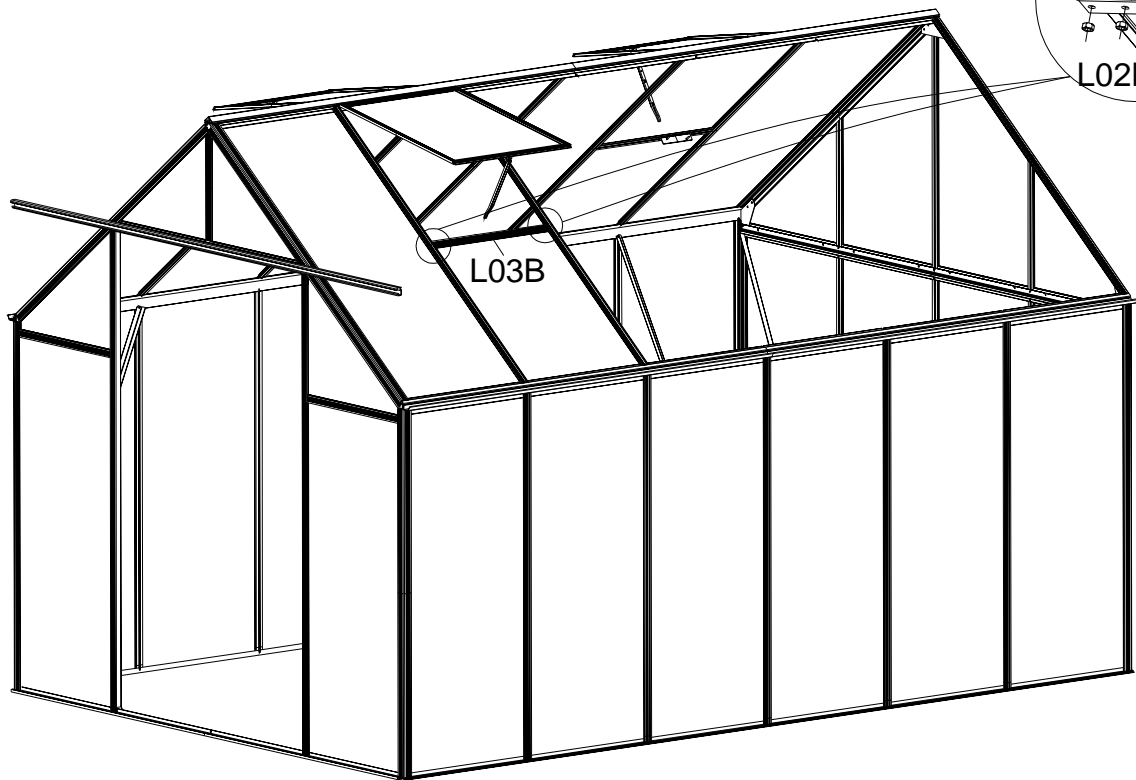
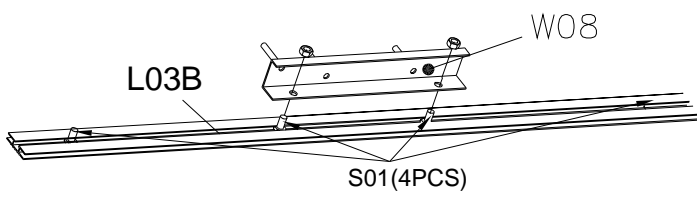

Step 22

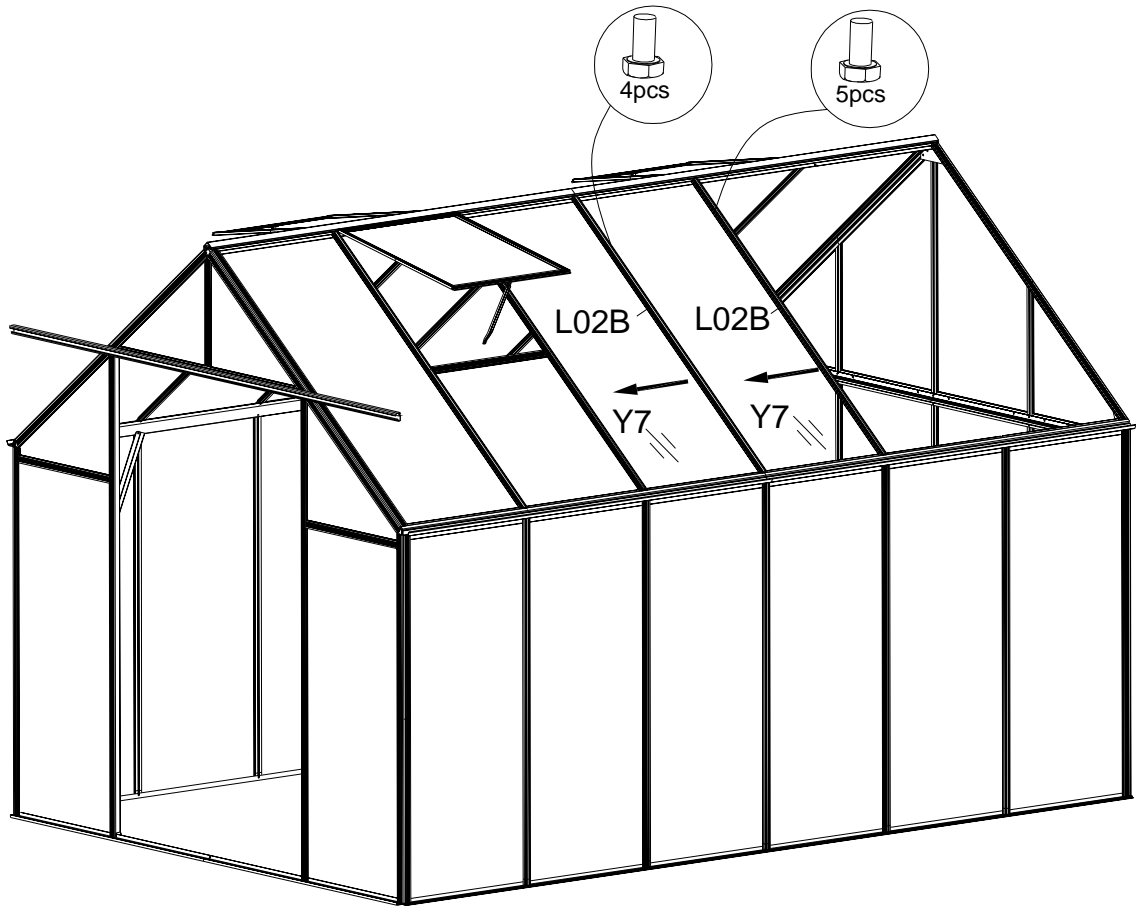

Step 23

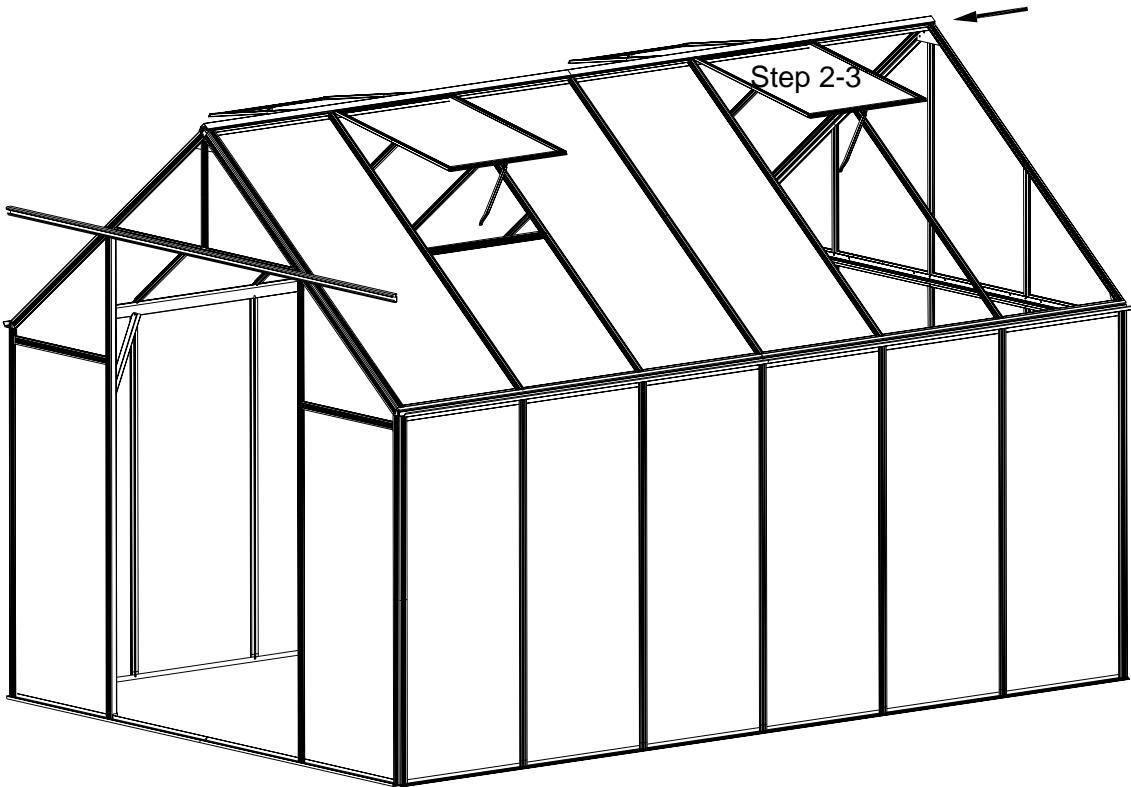

Step 24

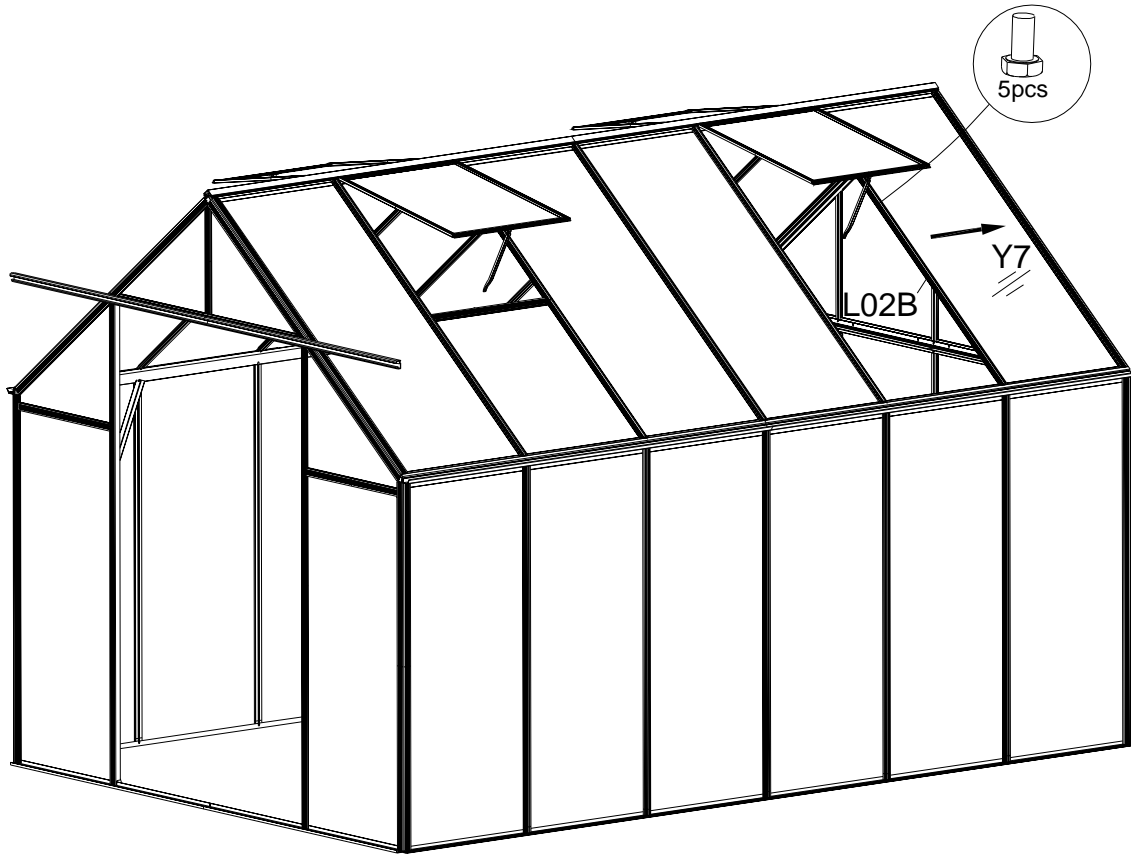

Step 25

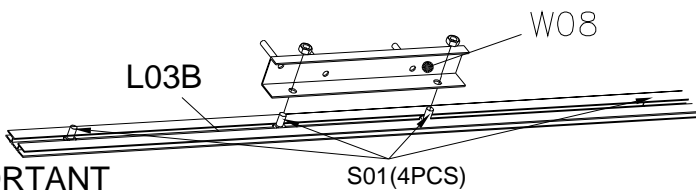

IMPORTANT

Y9 is the last piece of polycarbonate to go in. Slide L03B up. Once Y9 is in position slide over Y9 to lock it in place. Gently bend the sheet to pop it into the extrusion

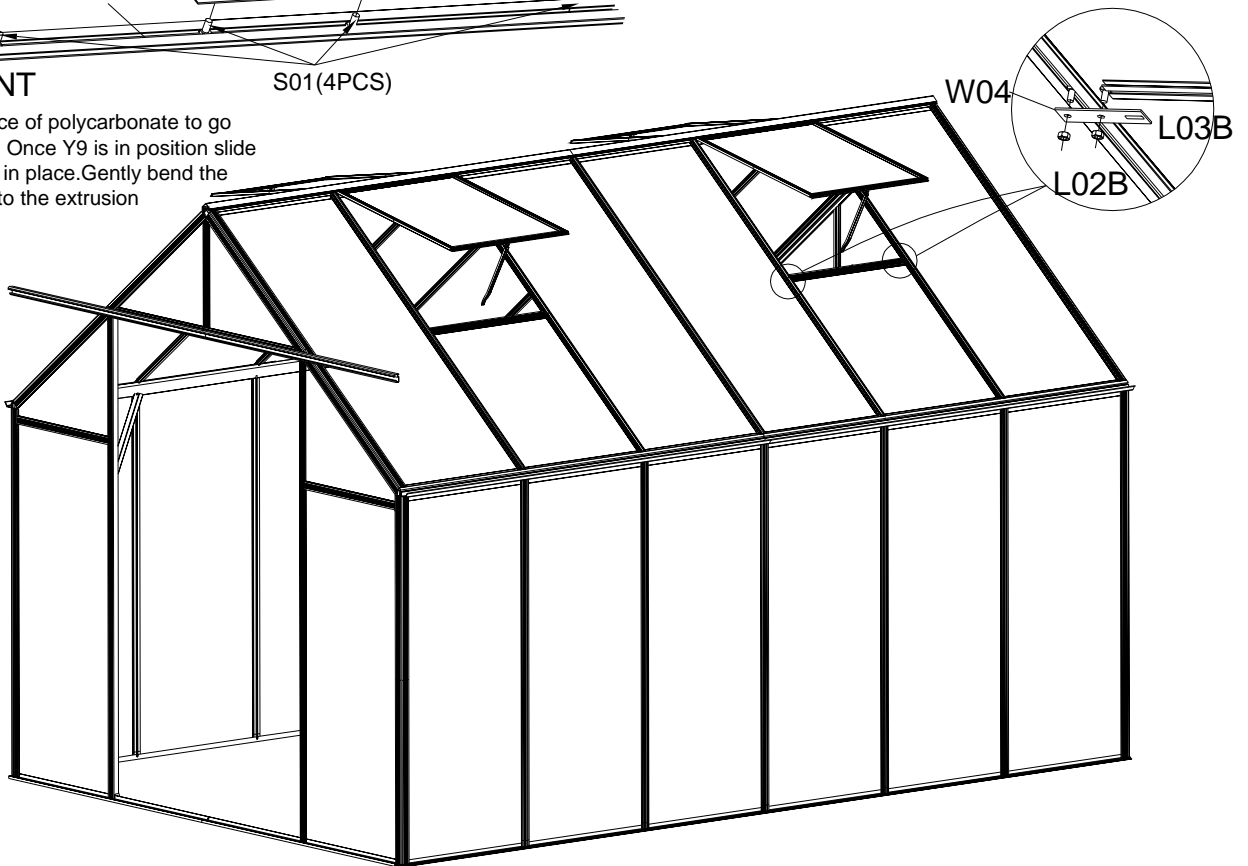

Step 26

