

Assembly Instruction

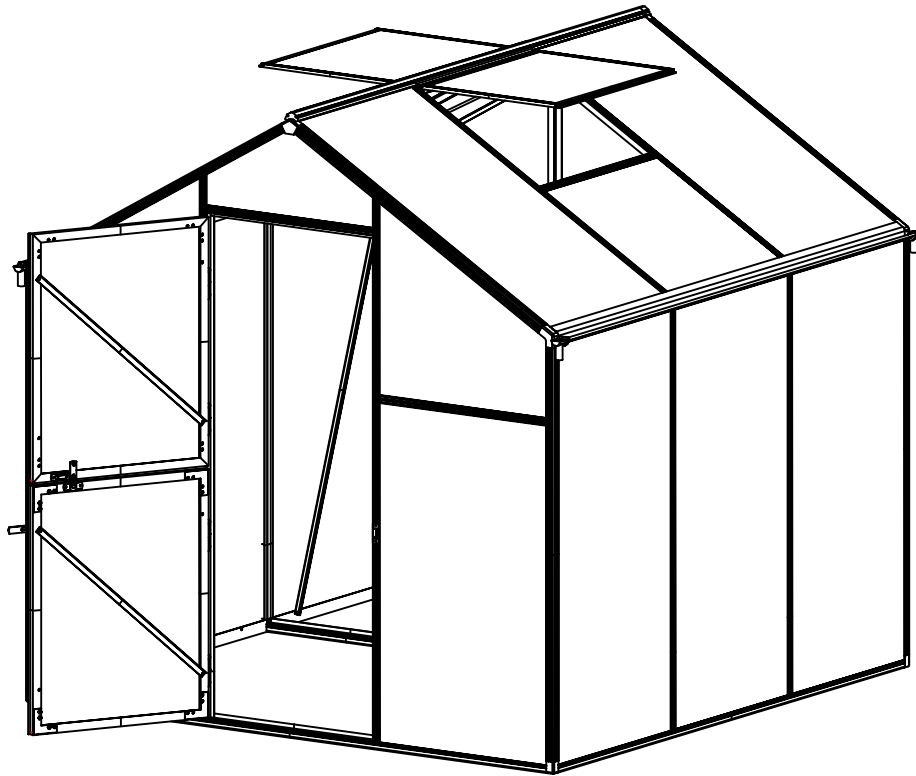

MODEL:GM30303

PRODUCT SIZE(LxWxH):Please refer to packing list

PLEASE READ CAREFULLY BEFORE ASSEMBLY

Item No. & Packing List

| 产品编号 | 产品尺寸 | Packing List | | | |
|---------|---------------|--------------|------------------|------------|------------------|
| | | 3Section | | 2Section-1 | |
| | | AL NO.1 | PC/Glass NO.1 | AL NO.2 | PC/Glass NO.2 |
| GM33303 | 210x210x210CM | 1CTN | 1CTN | | |
| GM33305 | 347x210x210CM | 1CTN | 1CTN | 1CTN | 1CTN |
| GM33307 | 484x210x210CM | 1CTN | 1CTN | 2CTN | 2CTN |
| etc. | | etc. | etc. | etc. | etc. |

产品的安装及保养

1. 需要两个或者两个以上人员一起进行安装
2. 铝材表面可能有毛刺，务必戴上手套
3. 安装期间，在地上放一块柔软的平台，以防部件刮伤和损坏
4. 不能攀爬或站在产品顶部，重物不能放置在产品上。
5. 保持顶部和水槽无积雪无树叶，大量的积雪可破坏产品，并使人处于危险的状态。
6. 一些产品有喷漆处理，如安装过程中，产品有刮花，可自行喷漆处理。
7. 当您的产品需要清理，则需用一些温和的清洁剂清理，同时用冷水冲洗，不能用有腐蚀作用的清洁剂。

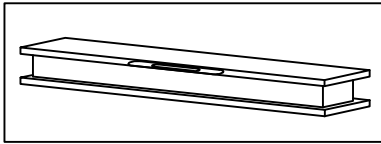
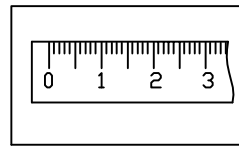
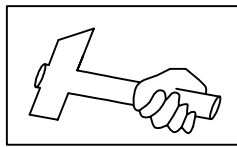
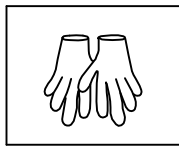
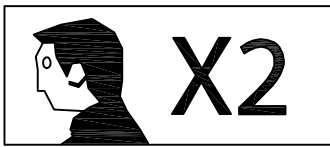
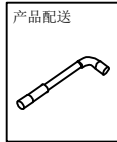
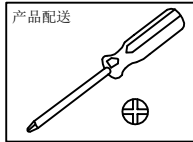
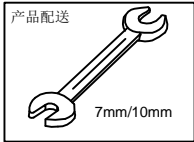

产品的功能与特性

1. Compared to other traditional greenhouses, this product improves its aluminum profile from single layer into tube structure, which makes it much stronger and can be held more pressure.

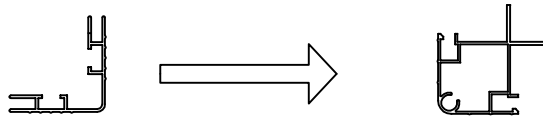

2. Easy and fast assembly.

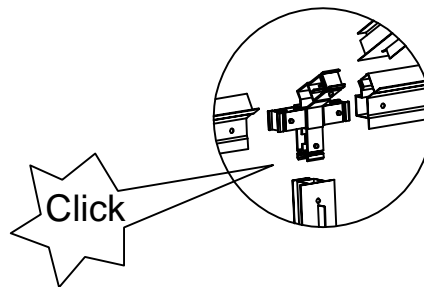

3. To avoid any rusts, galvanized steel base is out of this product. Another two ways are available to choose. One is to use expansion screw to fix into concrete ground (default/standard); the other is to use sharp steel bar to fix into lawn land. (optional/extra charge).

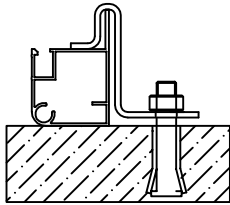

Expansion screw/Concrete ground

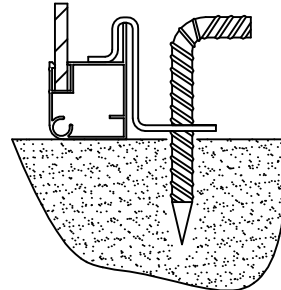

Steel bar/Lawn land

4. Convenient for transportation with no more than 2.8 meters' length of each carton box.

5. Gutter and water pipe are designed for environmental protection in this product. Rain water can be used for saving energy too.

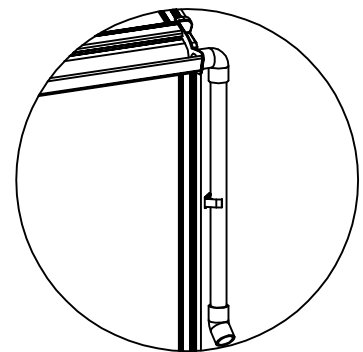

6. Two window openers are available. One is manual opener (default/standard); the other is automatic opener, item no.: JXX80001 (optional/extra charge).

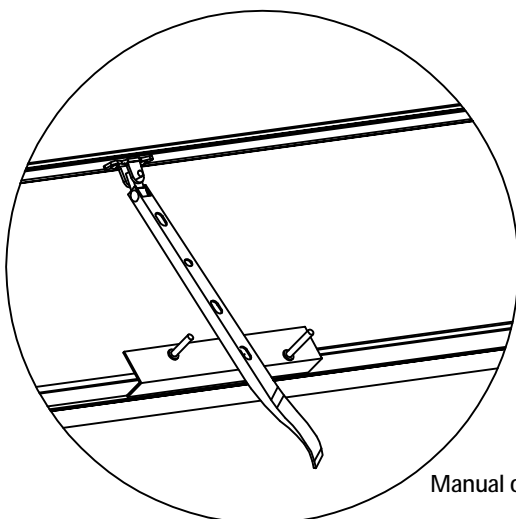

Manual opener

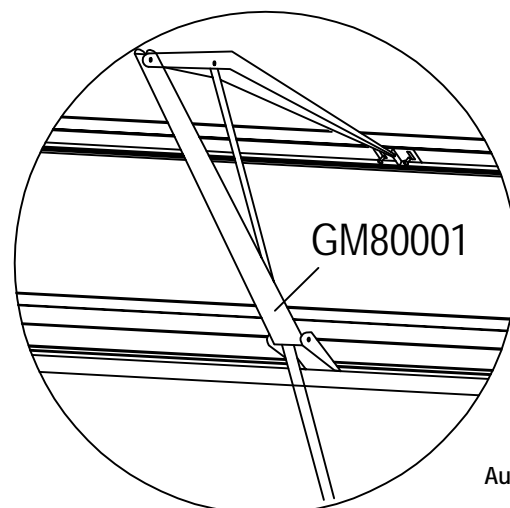

Automatic opener

7. Customers can also choose double doors on both ends.
If it is double doors on both ends, please pick two
Front Assemblys only, instead of one Front and one Back .

8. Please make sure the PC panel the side with words faces out.

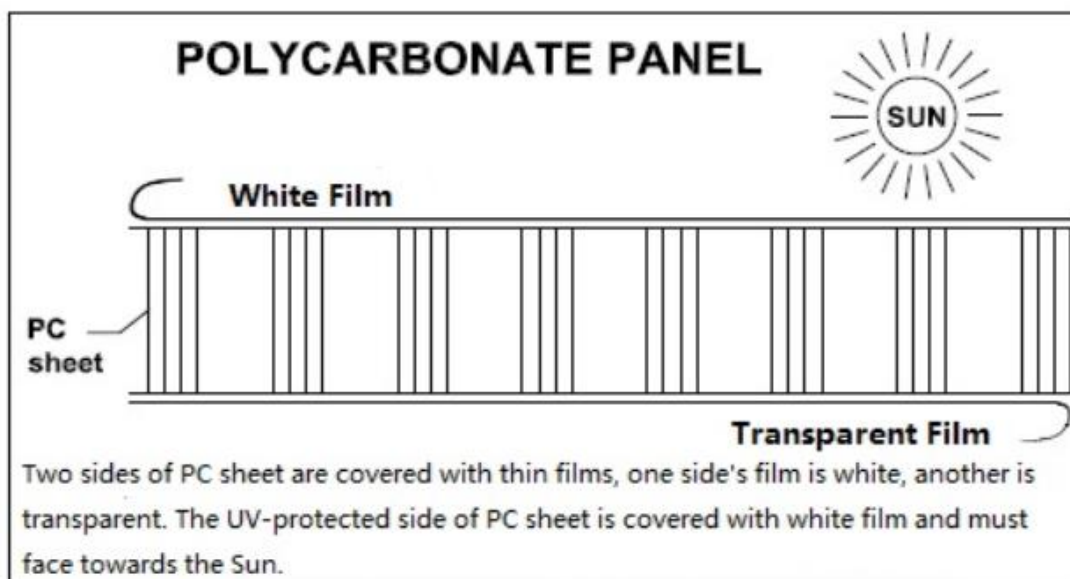



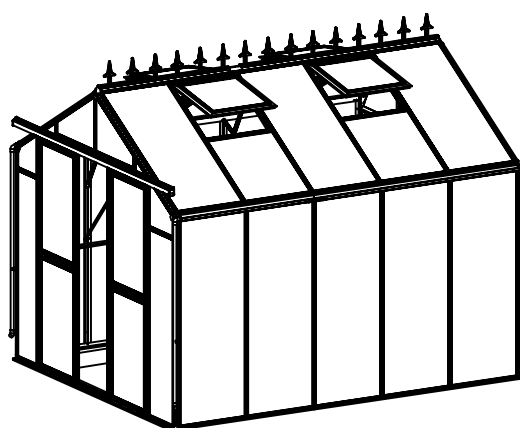
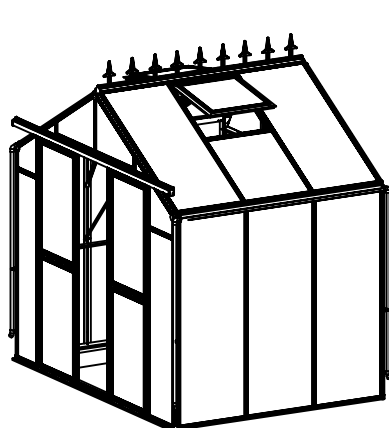



9. 该产品可以无限延伸, 可以根据实际情况购买需要的长度,
3格、5格、7格或者更长













...
etc.

GM33303(ALU. Box No.1)









Door Assembly

| PART | NO | QTY |
|--|------|-----|
|  | L18A | 2 |
|  | L18B | 2 |
|  | L17 | 1 |
|  | L16A | 1 |
|  | L16B | 1 |
|  | L16C | 1 |
|  | L05G | 2 |













Front Assembly

| PART | NO | QTY |
|--|------|-----|
|  | L01A | 1 |
|  | L01B | 1 |
|  | L01C | 1 |
|  | L01D | 1 |
|  | L03E | 1 |
|  | L03F | 1 |
|  | L04B | 2 |
|  | L04A | 1 |
|  | L05A | 2 |
|  | L08A | 1 |























Back Assembly

| PART | NO | QTY |
|--|------|-----|
|  | L01A | 2 |
|  | L01B | 1 |
|  | L01C | 1 |
|  | L03C | 1 |
|  | L03D | 1 |
|  | L04B | 3 |
|  | L05A | 2 |
|  | L08A | 1 |

3 Sections

| PART | NO | QTY |
|---|------|-----|
|  | L02A | 4 |
|  | L02B | 4 |
|  | L06A | 1 |
|  | L07A | 2 |
|  | L08A | 2 |
|  | L09A | 2 |
|  | L05C | 4 |
|  | L05D | 4 |
|  | L15A | 2 |
|  | L19 | 4 |
|  | L20 | 2 |
|  | L21 | 2 |
|  | L04B | 2 |

Parts

| PART | NO | QTY |
|---|---------------|-----|
|  | A | 2 |
|  | B | 2 |
|  | D | 2 |
|  | E | 2 |
|  | F | 2 |
|  | J | 8 |
|  | W01 | 4 |
|  | W04 | 4 |
|  | W05 | 11 |
|  | W06 | 2 |
|  | W08 | 2 |
|  | S01 M6X10 | 76 |
|  | M01 M6 | 76 |
|  | S03 M8X60 | 11 |
|  | Z01 Ø4X14D | 40 |
|  | Z02 Ø5X15 | 8 |
|  | Z03 Ø4X8 | 4 |
|  | J01 | 2 |
|  | J02R/L | 2/2 |
|  | J03R/L | 2/2 |
|  | J07R/L | 2/2 |
|  | J08 | 4 |

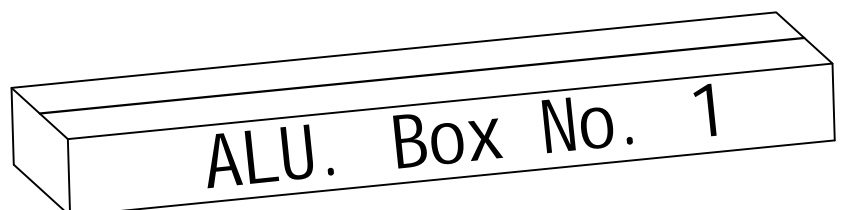





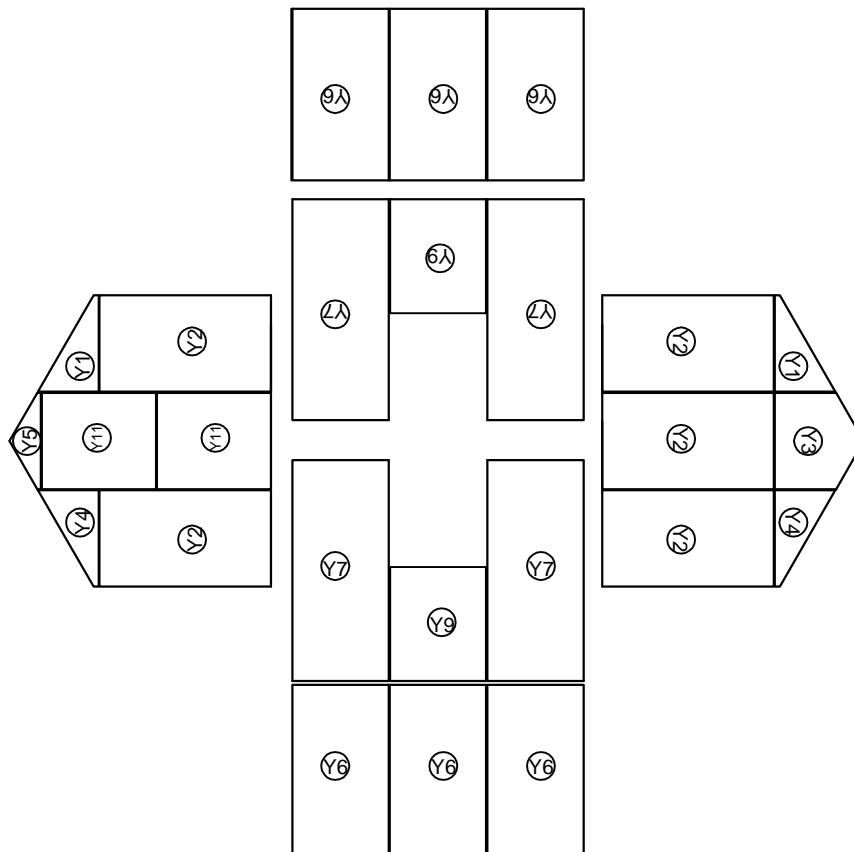
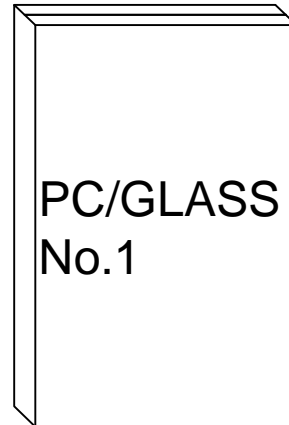





























GM33303(PC/GLASS No.1)

| | | |
|--|-----|---|
| | Y1 | 2 |
| | Y2 | 5 |
| | Y3 | 1 |
| | Y4 | 2 |
| | Y5 | 1 |
| | Y6 | 6 |
| | Y7 | 4 |
| | Y9 | 2 |
| | Y10 | 2 |
| | Y11 | 2 |





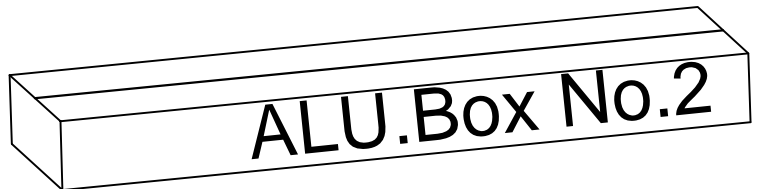

EXT. 2 Sections(AU.Box No.2)

| 2 Section | | |
|--|------|-----|
| PART | NO | QTY |
|  | L02A | 2 |
|  | L02B | 2 |
|  | L04B | 2 |
|  | L05C | 2 |
|  | L05D | 2 |
|  | L06 | 1 |
|  | L07 | 2 |
|  | L08 | 2 |
|  | L08D | 2 |
|  | L09 | 2 |
|  | L10A | 2 |
|  | L10B | 2 |
|  | L10C | 2 |
|  | L15A | 2 |
|  | L19 | 4 |
|  | L20 | 2 |
|  | L21 | 2 |









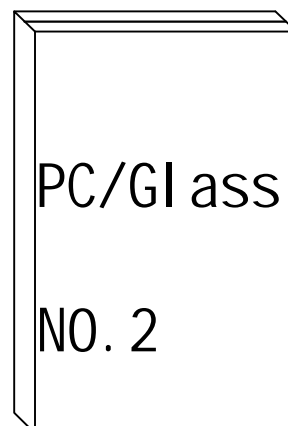
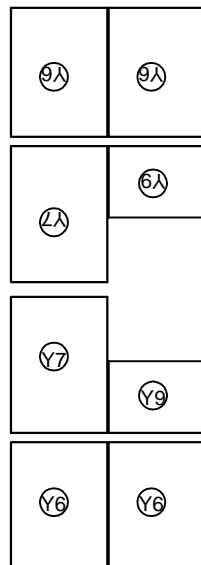





















| Parts | | |
|---|--------|-----|
| PART | NO | QTY |
|  | C | 2 |
|  | G | 2 |
|  | H | 1 |
|  | K | 2 |
|  | W02 | 2 |
|  | W04 | 2 |
|  | W05 | 6 |
|  | W06 | 2 |
|  | W08 | 2 |
|  | S01 | 30 |
| | M6X10 | |
|  | M01 | 30 |
| | M6 | |
|  | S03 | 6 |
| | M8X60 | |
|  | Z01 | 16 |
| | Ø4X16D | |
|  | Z02 | 6 |
| | Ø5X15 | |
|  | Z03 | 4 |
| | Ø4X8 | |
|  | J04 | 2 |
|  | J05 | 2 |
|  | J06 | 1 |



EXT. 2 Sections(PC/GLASS No.2)









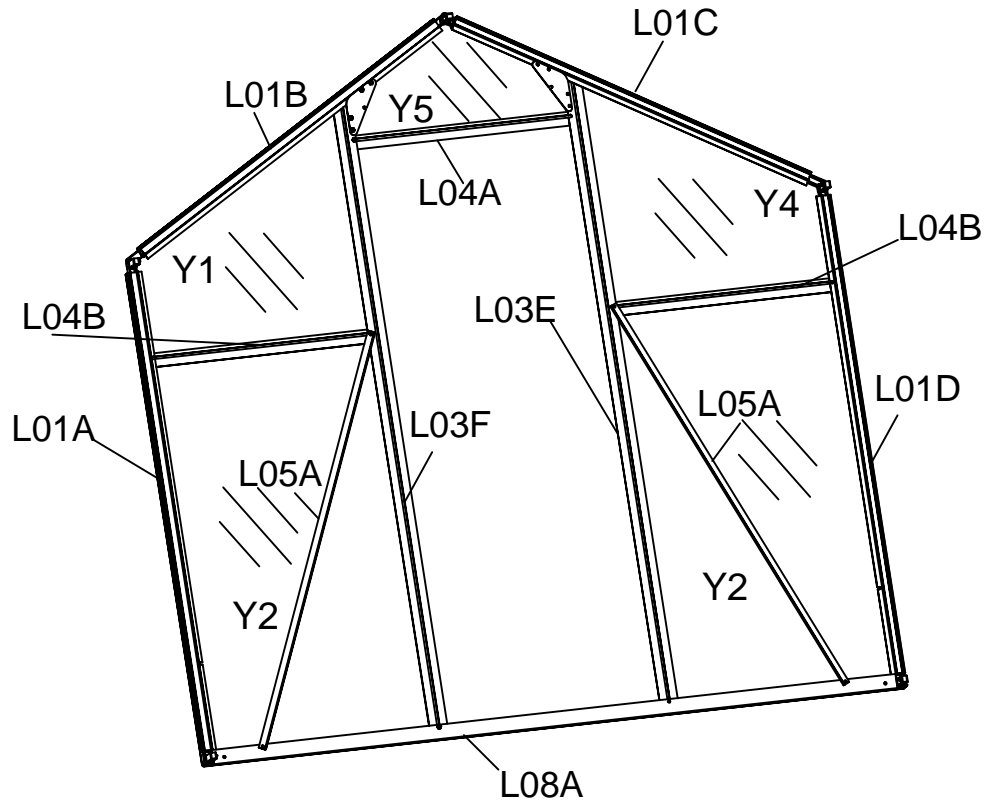



















| | | |
|---|-----|---|
|  | Y6 | 4 |
|  | Y7 | 2 |
|  | Y9 | 2 |
|  | Y10 | 2 |



| PART | NO. | QTY. | PART | NO. | QTY. | PART | NO. | QTY. |
|--|------|------|---|---------------|------|---|-----|------|
|  | L01A | 1 |  | A | 1 |  | Y1 | 1 |
|  | L01B | 1 |  | B | 1 |  | Y2 | 2 |
|  | L01C | 1 |  | D | 1 |  | Y5 | 1 |
|  | L01D | 1 |  | E | 1 |  | Y4 | 1 |
|  | L03E | 1 |  | F | 1 | | | |
|  | L03F | 1 |  | W01 | 2 | | | |
|  | L04B | 2 |  | S01 M6X10 | 18 | | | |
|  | L04A | 1 |  | M01 M6 | 18 | | | |
|  | L05A | 2 |  | Z01 Ø4X16D | 4 | | | |
|  | L08A | 1 |  | W05 | 2 | | | |
| | | |  | S03 M8X60 | 2 | | | |
| | | |  | J01 | 1 | | | |
| | | |  | J02R/L | 1/1 | | | |
| | | |  | J03R/L | 1/1 | | | |
| | | |  | J07R/L | 1/1 | | | |
| | | |  | J08 | 2 | | | |









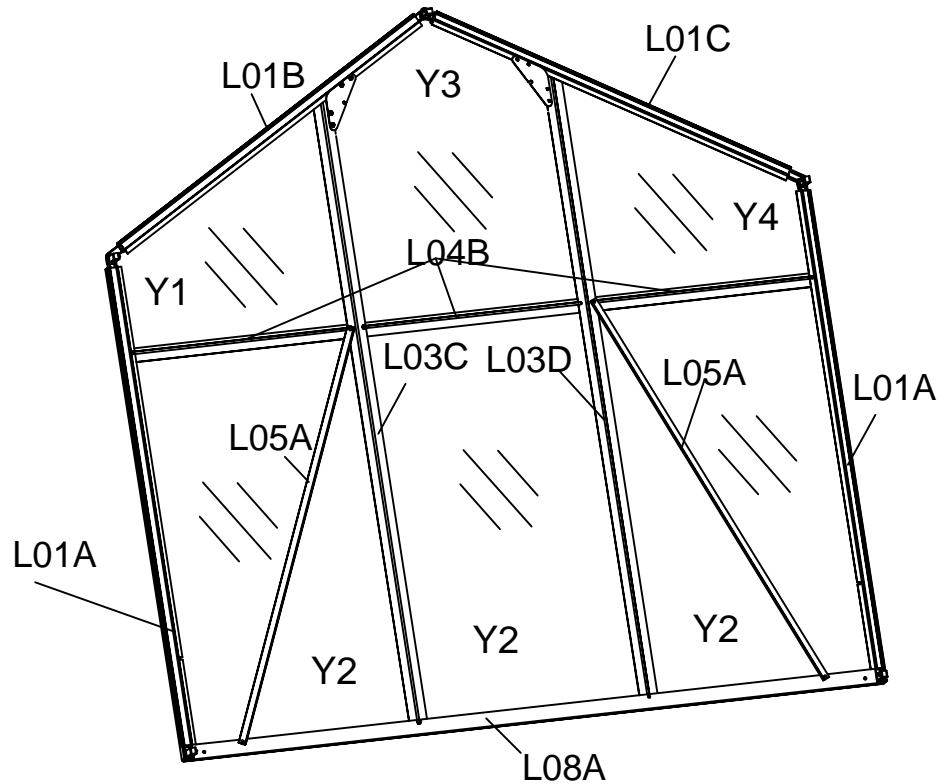

















Front Assembly



| PART | NO. | QTY. | PART | NO. | QTY. | PART | NO. | QTY. |
|--|------|------|---|--------|------|---|-----|------|
|  | L01A | 2 |  | A | 1 |  | Y1 | 1 |
|  | L01B | 1 |  | B | 1 |  | Y2 | 3 |
|  | L01C | 1 |  | D | 1 |  | Y3 | 1 |
|  | L03C | 1 |  | E | 1 |  | Y4 | 1 |
|  | L03D | 1 |  | F | 1 | | | |
|  | L04B | 3 |  | W01 | 2 | | | |
|  | L05A | 2 |  | Z01 | 4 | | | |
|  | L08A | 1 |  | S01 | 18 | | | |
| | | |  | M01 | 18 | | | |
| | | |  | W05 | 3 | | | |
| | | |  | S03 | 3 | | | |
| | | |  | J01 | 1 | | | |
| | | |  | J02R/L | 1/1 | | | |
| | | |  | J03R/L | 1/1 | | | |
| | | |  | J07R/L | 1/1 | | | |
| | | |  | J08 | 2 | | | |









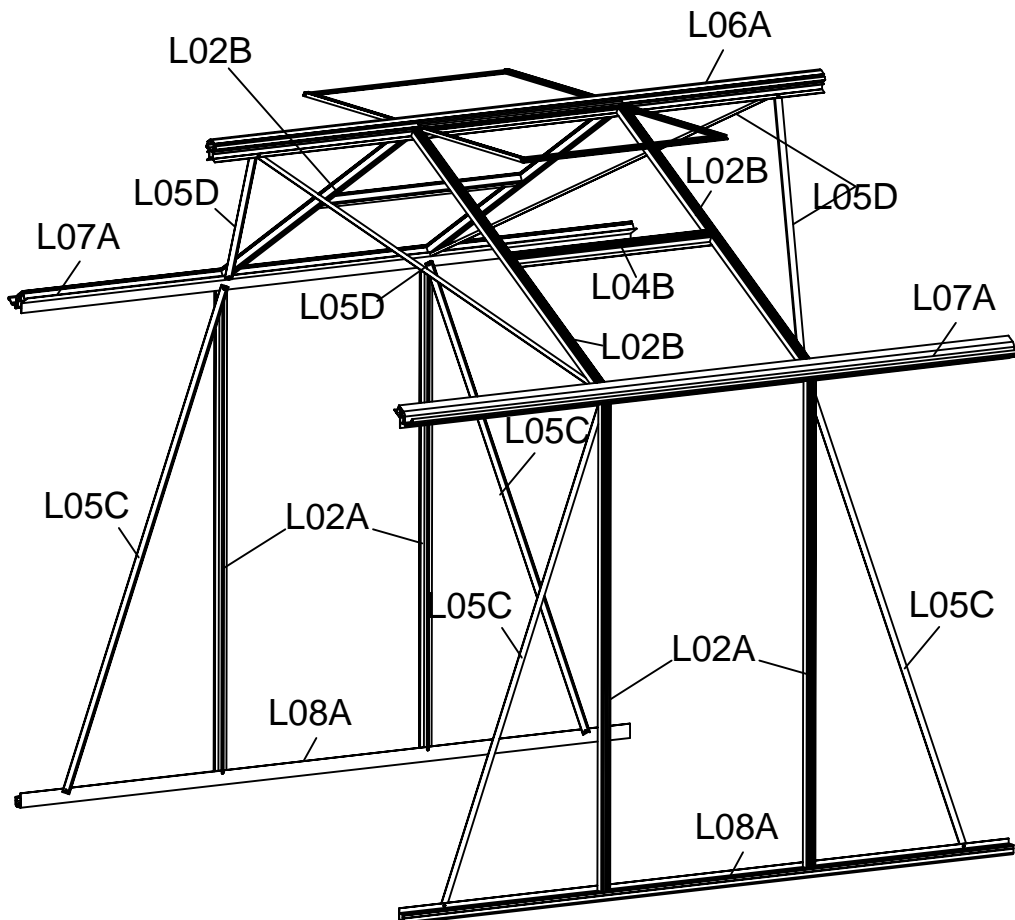





























Back Assembly



| PART | NO. | QTY. | PART | NO. | QTY. | PART | NO. | QTY. |
|---|------|------|---|---------------|------|---|-----|------|
|  | L02A | 4 |  | W06 | 2 |  | Y6 | 6 |
|  | L02B | 4 |  | W08 | 2 |  | Y7 | 4 |
|  | L06A | 1 |  | W04 | 4 |  | Y9 | 2 |
|  | L07A | 2 |  | S01 M6X10 | 36 |  | Y10 | 2 |
|  | L08A | 2 |  | M01 M6 | 36 | | | |
|  | L09A | 2 |  | Z01 Ø4X14D | 16 | | | |
|  | L05C | 4 |  | Z02 Ø5X15 | 8 | | | |
|  | L05D | 4 |  | Z03 Ø4X8 | 4 | | | |
|  | L15A | 2 |  | W05 | 6 | | | |
|  | L19 | 4 |  | S03 M8X60 | 6 | | | |
|  | L20 | 2 | | | | | | |
|  | L21 | 2 | | | | | | |
|  | L04B | 2 | | | | | | |

3 Sections Assembly Instruction



| PART | NO. | QTY. | PART | NO. | QTY. | PART | NO. | QTY. | PART | NO. | QTY. |
|--|------|------|---|------|------|---|-----|------|---|-----|------|
|  | L02A | 2 |  | L09 | 2 |  | C | 2 |  | S01 | 30 |
| | | | | | | | | | M6X10 | | |
|  | L02B | 2 |  | L10A | 2 |  | G | 2 |  | M01 | 30 |
| | | | | | | | | | M6 | | |
|  | L04B | 2 |  | L10B | 2 |  | H | 1 |  | Z01 | 16 |
| | | | | | | | | | Ø4X16D | | |
|  | L05C | 2 |  | L10C | 2 |  | K | 2 |  | Z02 | 6 |
| | | | | | | | | | Ø5X15 | | |
|  | L05D | 2 |  | L15A | 2 |  | W02 | 2 |  | Z03 | 4 |
| | | | | | | | | | Ø4X8 | | |
|  | L06 | 1 |  | L19 | 4 |  | W04 | 2 |  | W05 | 6 |
|  | L07 | 2 |  | L20 | 2 |  | W06 | 2 |  | S03 | 6 |
| | | | | | | | | | M8X60 | | |
|  | L08 | 2 |  | L21 | 2 |  | W08 | 2 |  | Y6 | 4 |
|  | L08D | 2 | | | |  | J04 | 2 |  | Y7 | 2 |
| | | | | | |  | J05 | 2 |  | Y9 | 2 |
| | | | | | |  | J06 | 2 |  | Y10 | 2 |

2 Sections Assembly Instruction

Middle Section Assembly Instruction

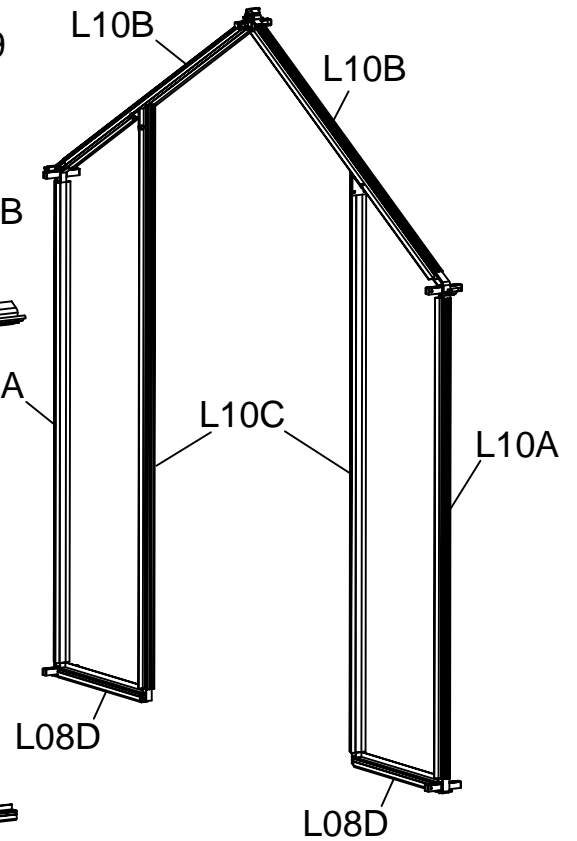
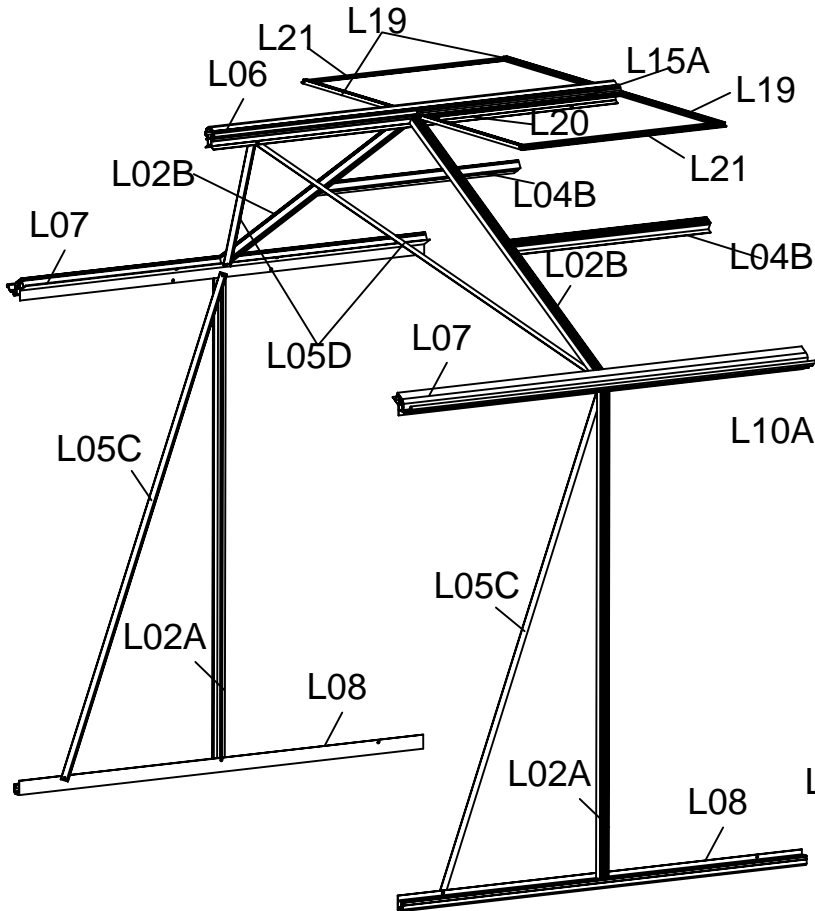

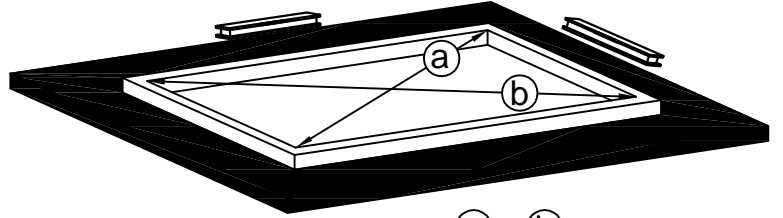
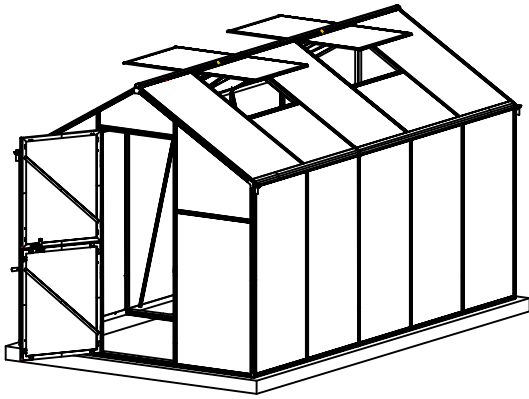

a = b

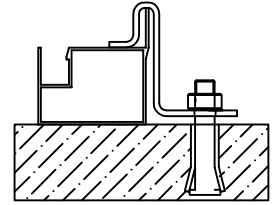
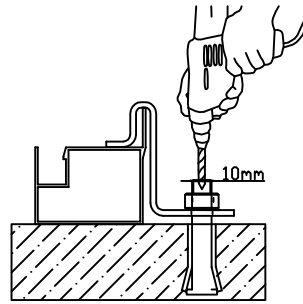

Expansion bolt in concrete



It is essential the dimensions a + b are the same to ensure the base is square.

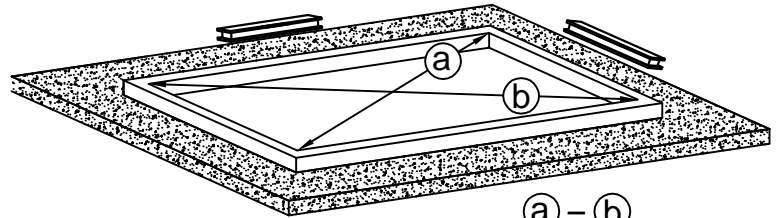
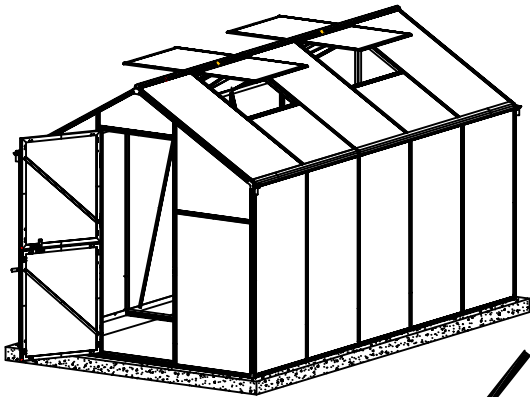

a = b

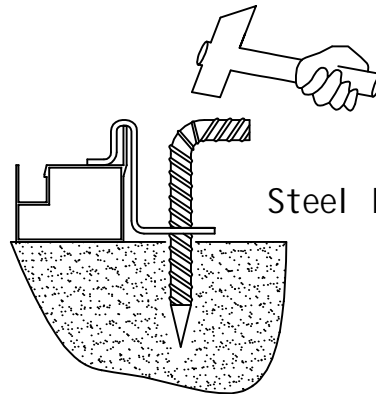

Steel bar/Lawn land

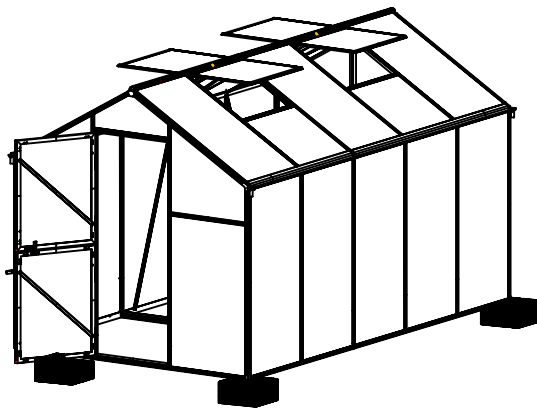

Back

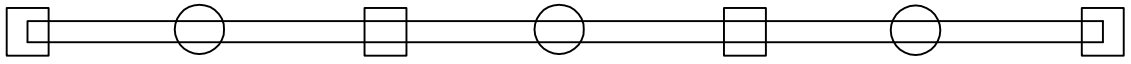

⋮



⋮

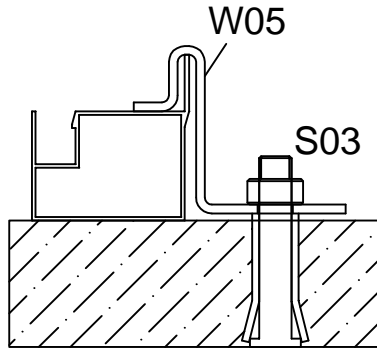

* 产品安装W05布局图, W05的安装位置约为每格阳光析的中间位置。

W05

W05

W05

Front

GM33303

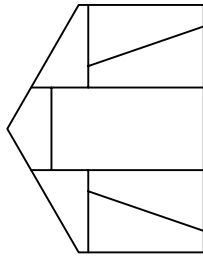
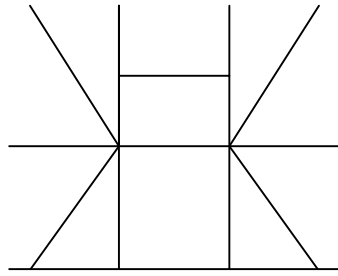

Front Assembly

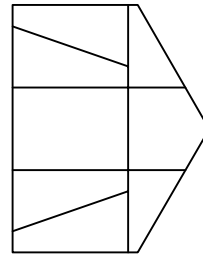
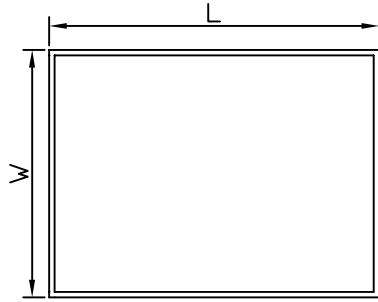

Back Assembly

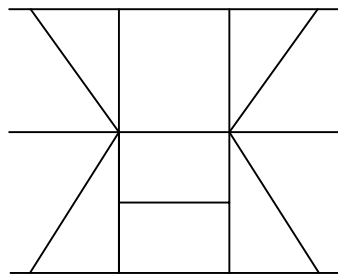

1 2 3
4 Section Assembly

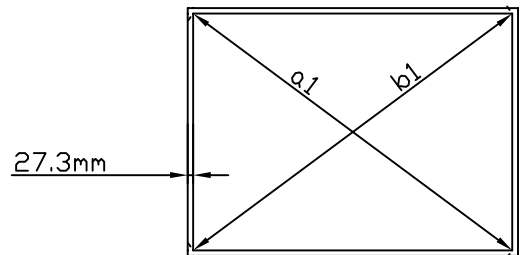

| Dim/Model | GM10 | GM10+Ext(1) | GM10+Ext(2) | GM10+Ext(3) | GM10+Ext(4) | GM10+Ext(5) | etc. |
|-----------|--------|-------------|-------------|-------------|-------------|-------------|------|
| W(mm) | 2092.2 | 2092.2 | 2092.2 | 2092.2 | 2092.2 | 2092.2 | |
| L (mm) | 2092.2 | 3463.8 | 4835.4 | 6207 | 7578.6 | 8950.2 | |
| a=b(mm) | 2958.8 | 4046.6 | 5268.6 | 6550.1 | 7795 | 9126 | |
| a1=b1(mm) | 2881.6 | 3917.7 | 5196.9 | 6481 | 7862.1 | 9191.5 | |

- * W=产品底座铝材外侧宽度;
- L=产品底座铝材外侧长度;
- a=b=产品底座铝材外侧对角线长度;
- a1=b1=产品底座铝材内侧对角线长度;

GM33303+Ext(1)

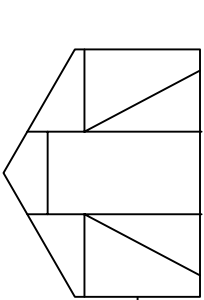
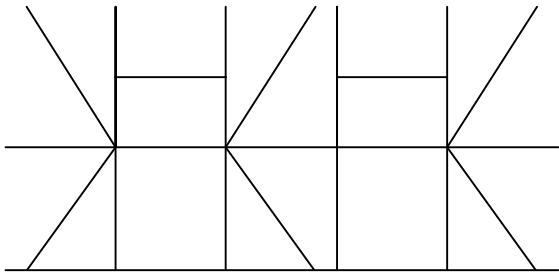

Front Assembly

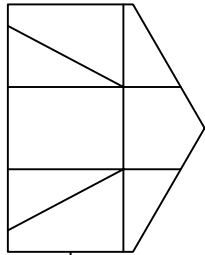
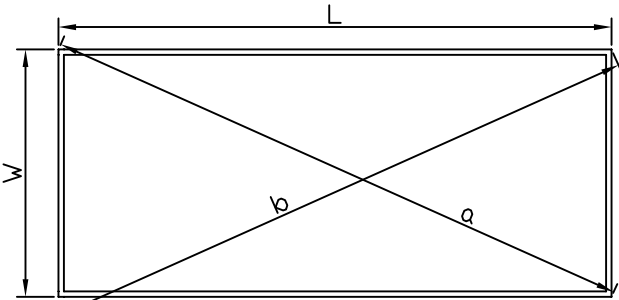

Back Assembly

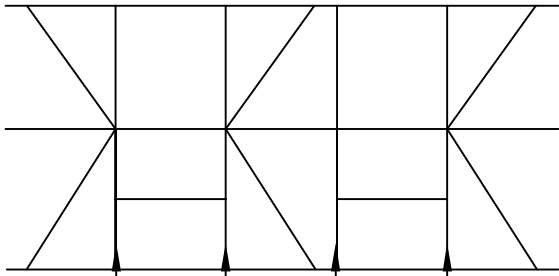













2 Section Assembly 2 Section Assembly 2 Section Assembly

Middle Section

GM33303

GM33303ext

* The basic model, GM33303, can be easily extended by adding a '2 Section Assembly' each time for a longer size



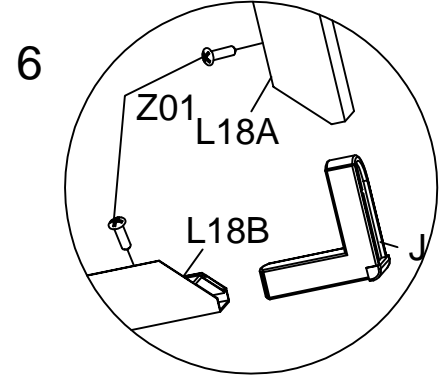
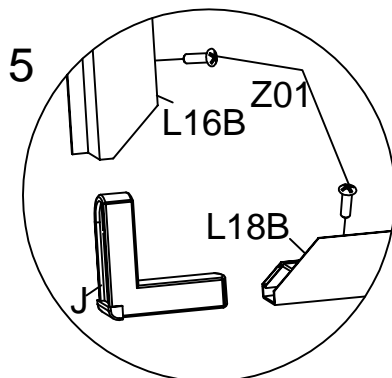
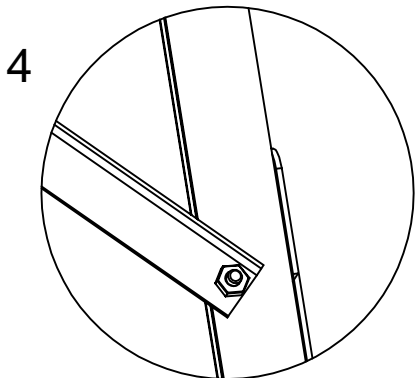
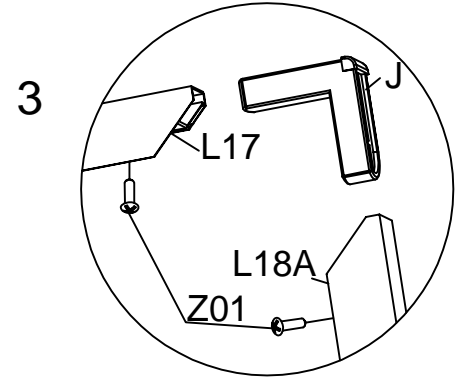
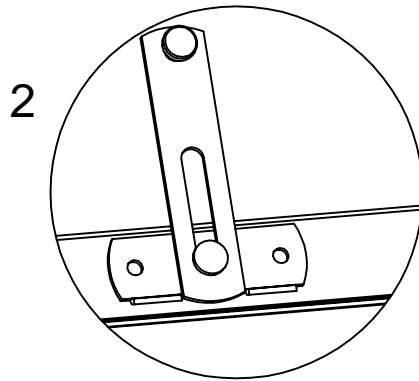
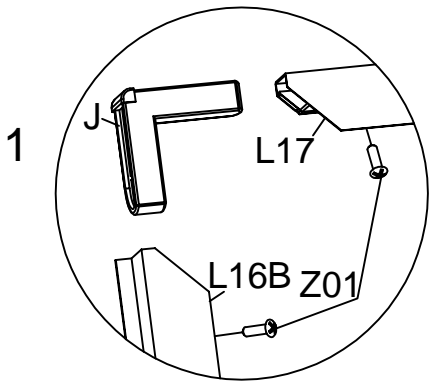
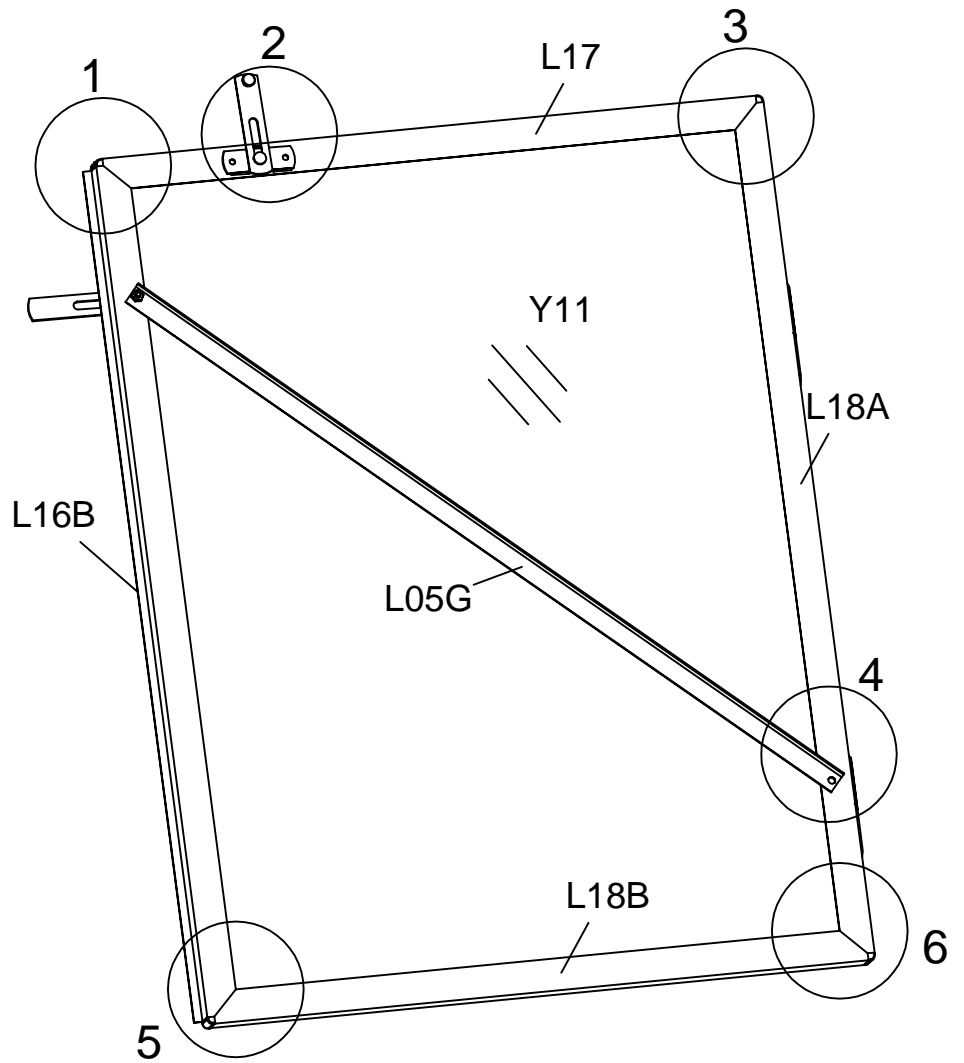

| PART | NO. | QTY. |
|---|--------|------|
|  | L18A | 2 |
|  | L18B | 2 |
|  | L17 | 1 |
|  | L16A | 1 |
|  | L16B | 1 |
|  | L16C | 1 |
|  | L05G | 2 |
|  | J | 8 |
|  | Z01 | 16 |
| | Ø4X16D | |
|  | S01 | 4 |
| | M6X10 | |
|  | M01 | 4 |
| | M6 | |
|  | Y11 | 2 |

Door1 Assembly

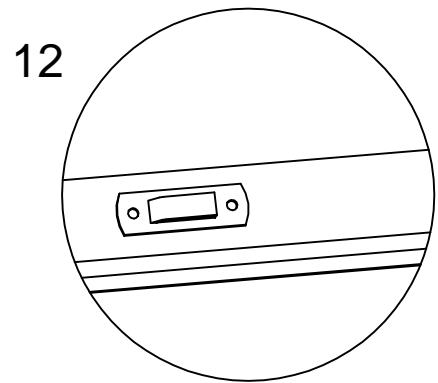
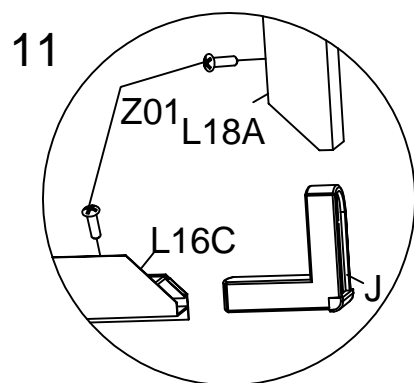
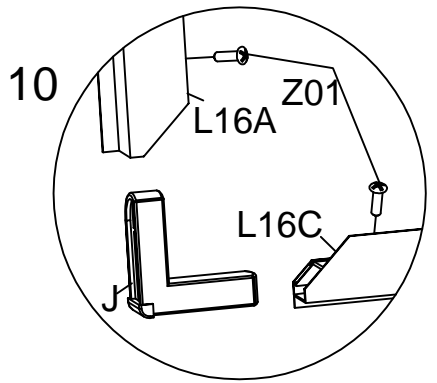
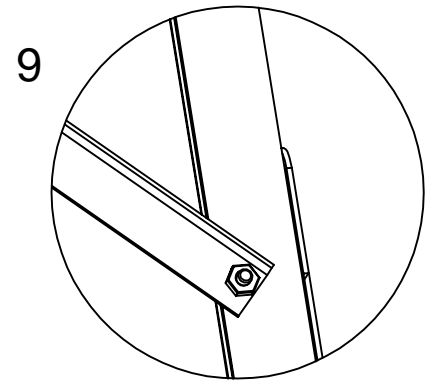
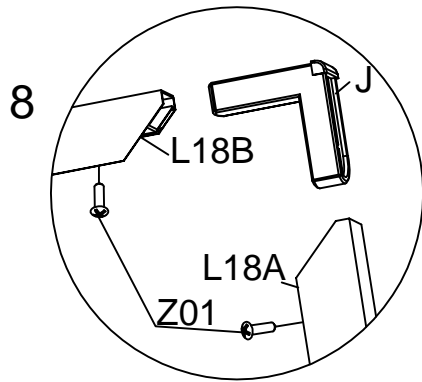
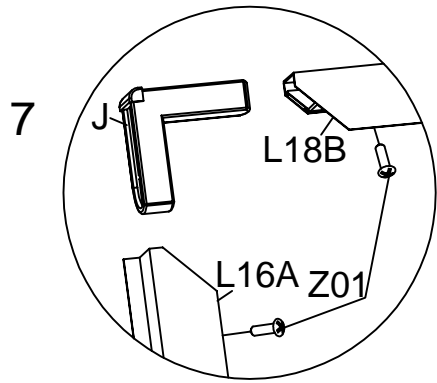
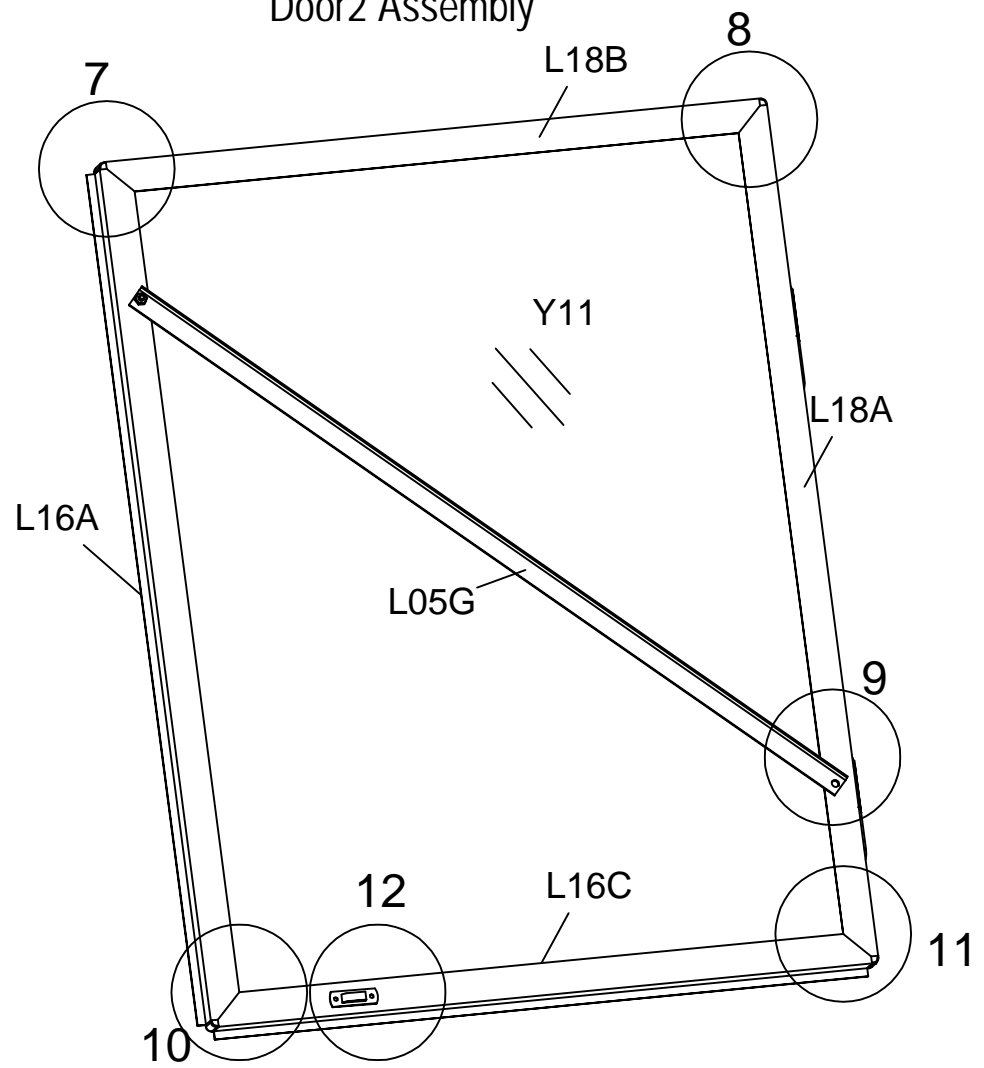

Door2 Assembly



| PART | NO. | QTY. |
|--|--------|------|
|  | L15A | 1 |
|  | L19 | 2 |
|  | L20 | 1 |
|  | L21 | 1 |
|  | Z01 | 8 |
| | Ø4X16D | |

Roof Vent Assembly

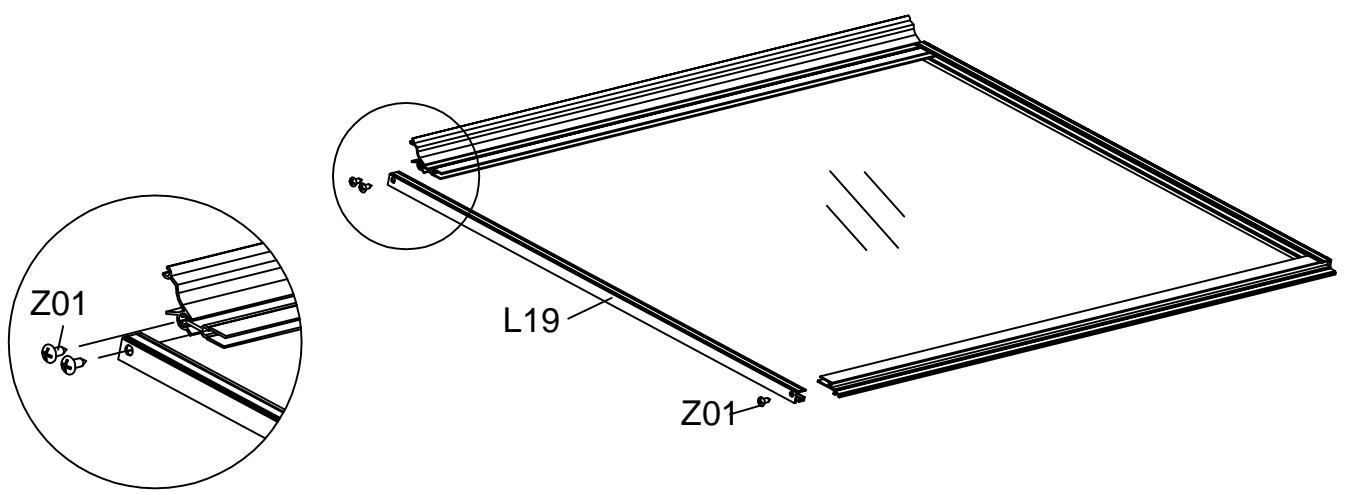
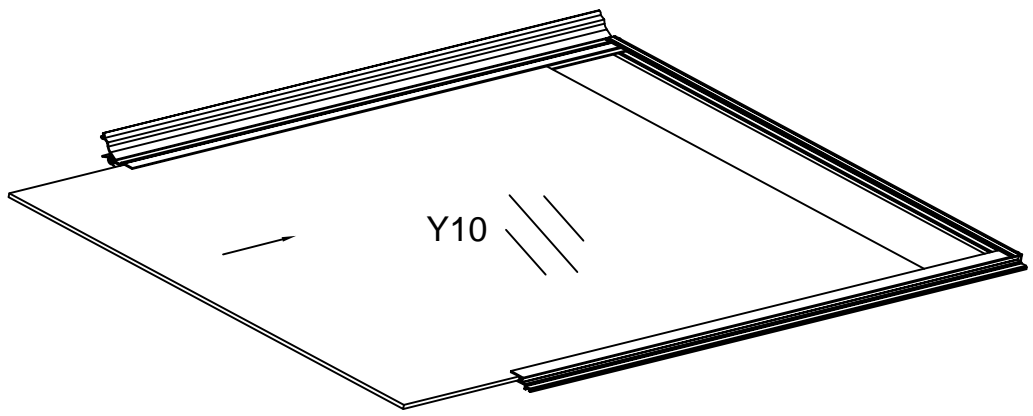
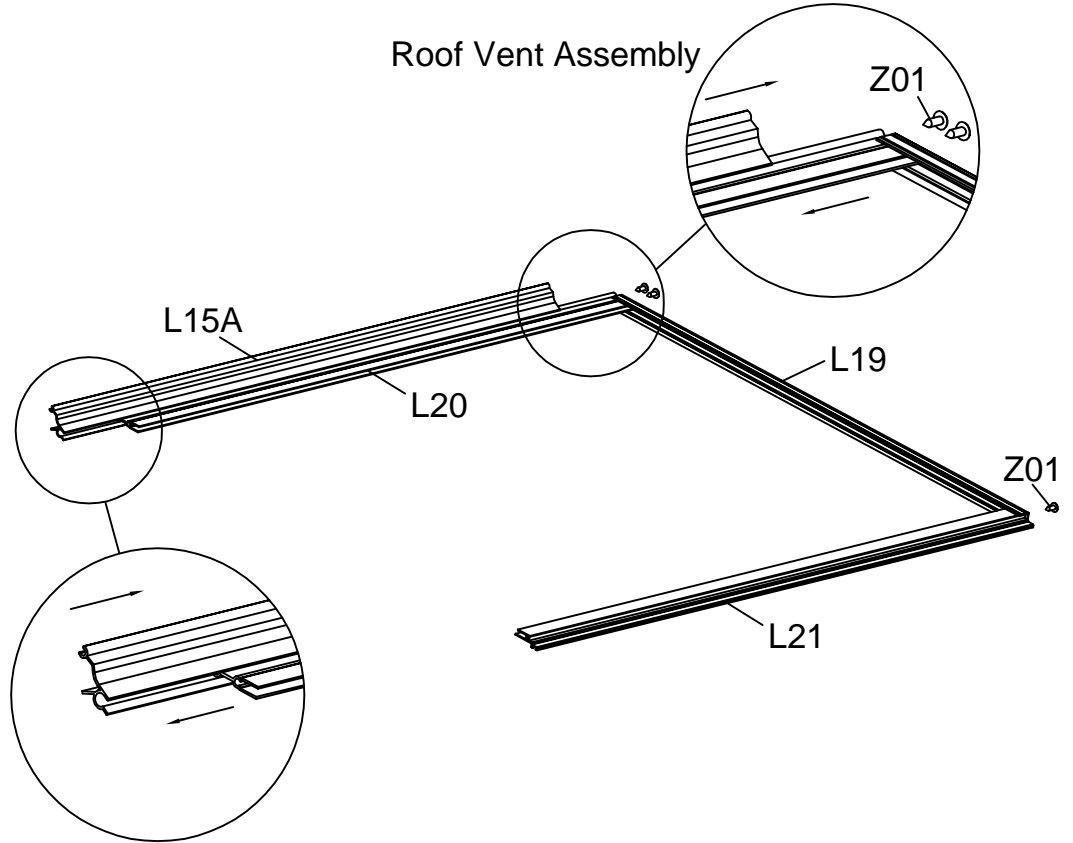

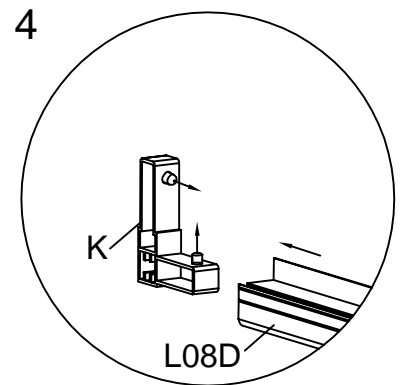
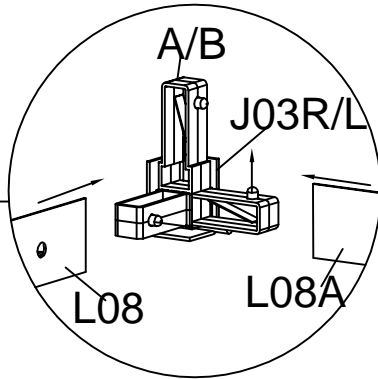
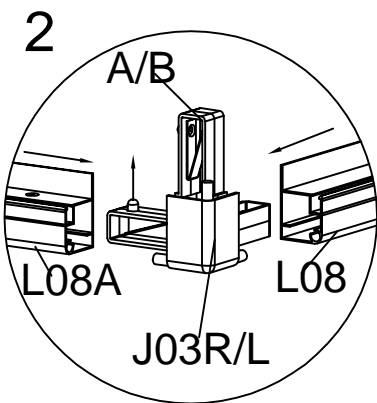
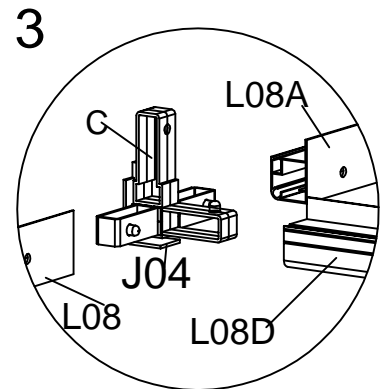
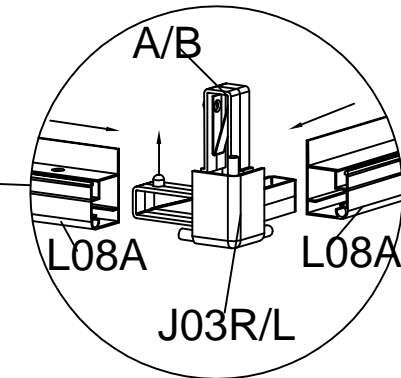
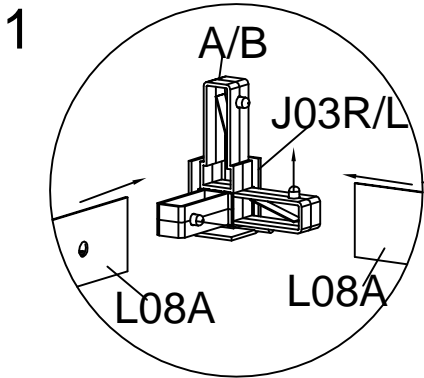
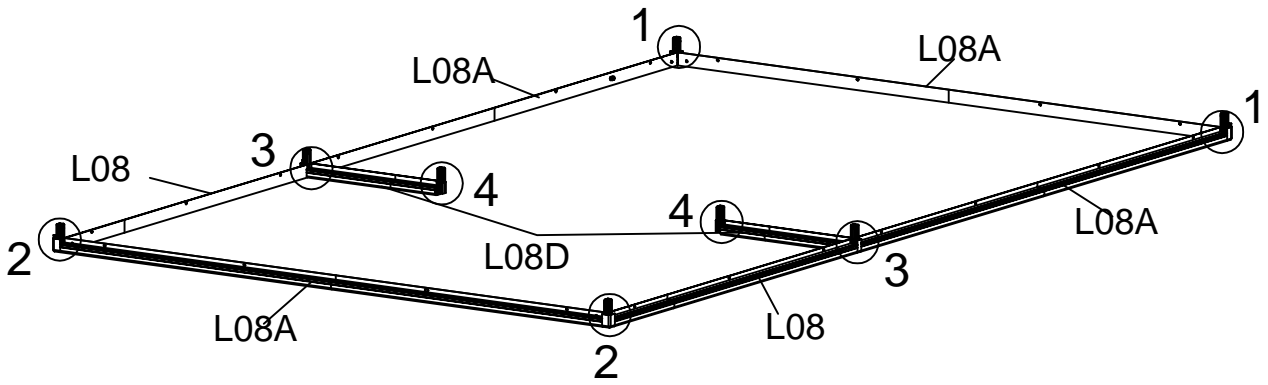

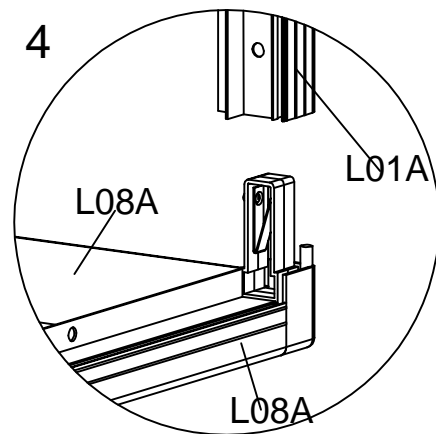
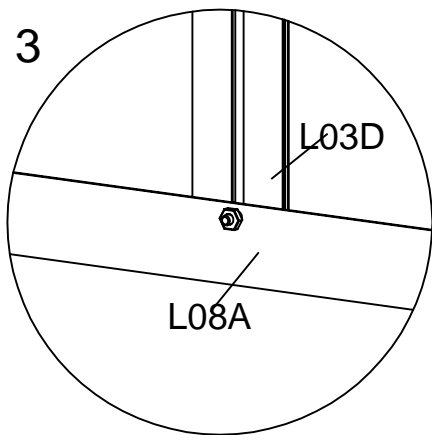
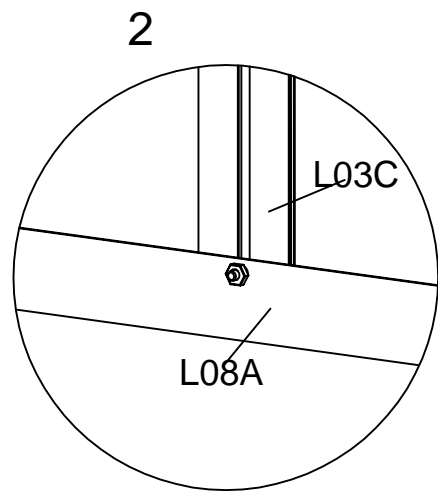
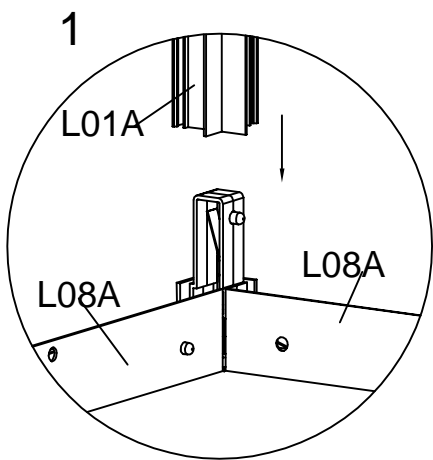
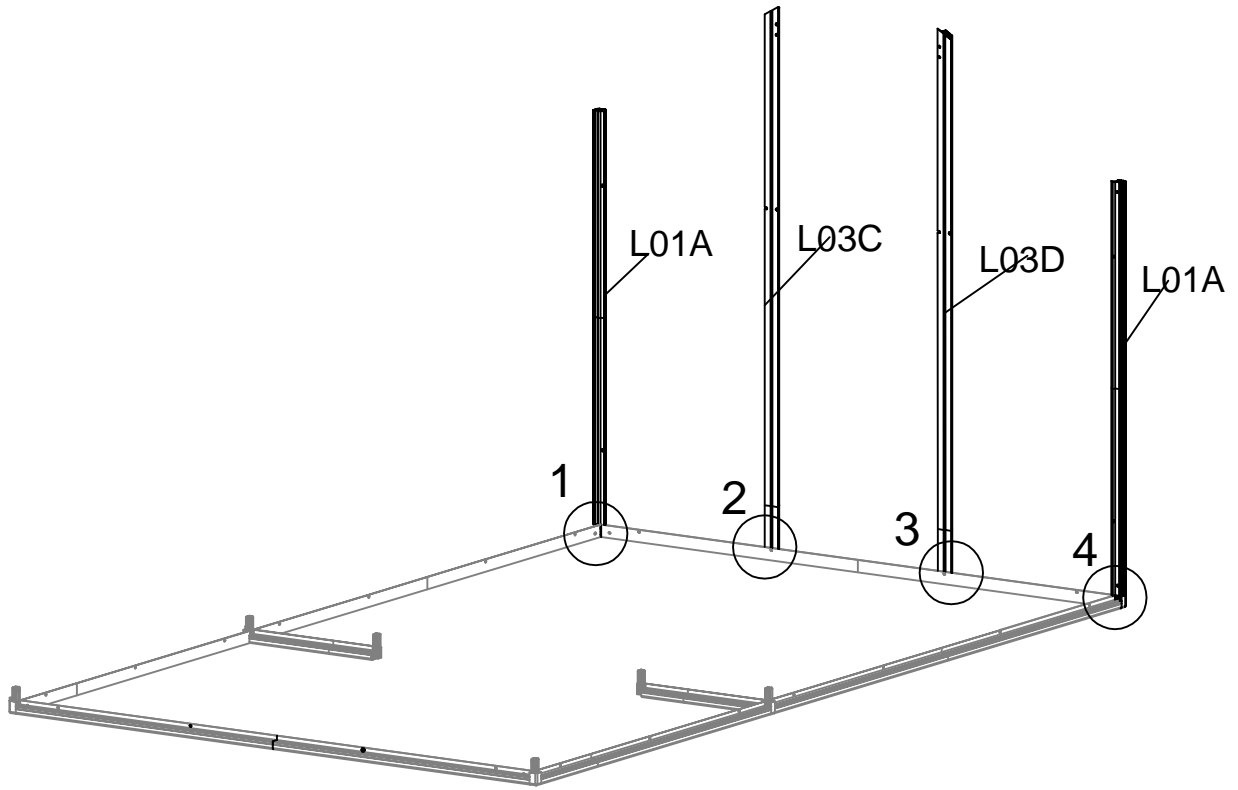

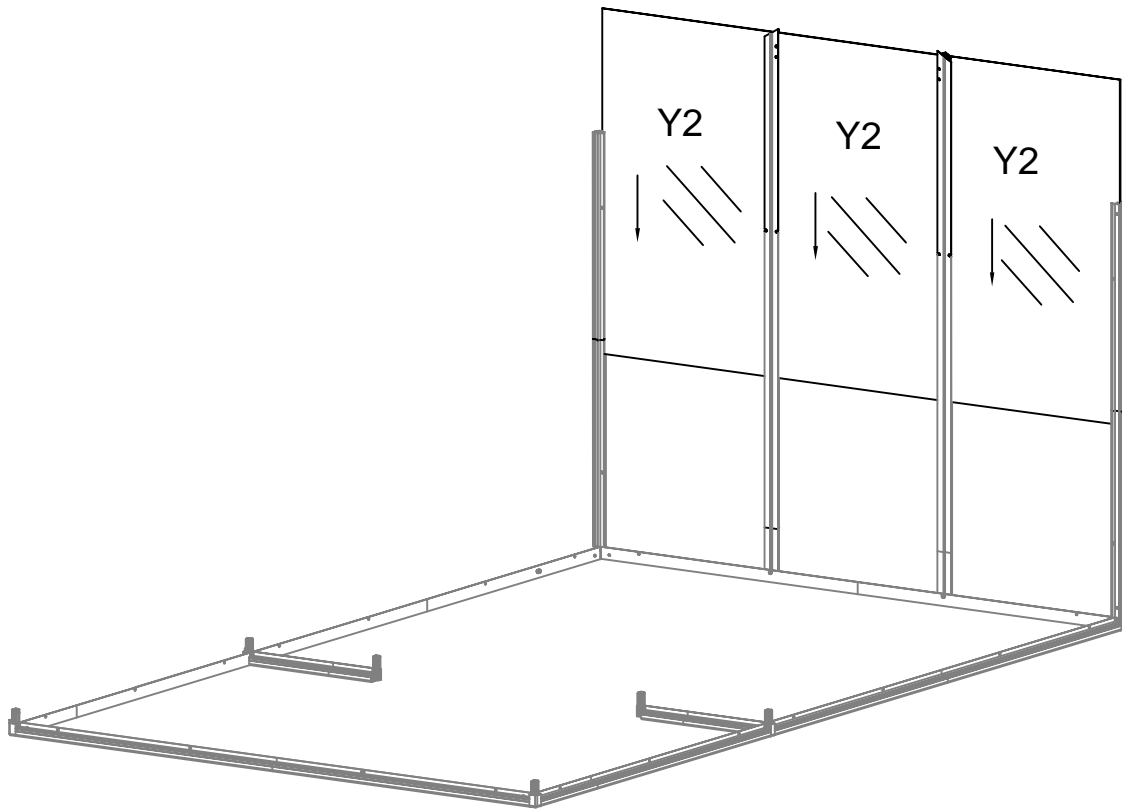

1

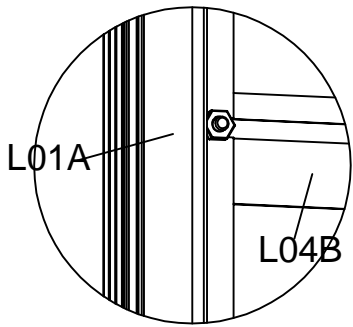

2

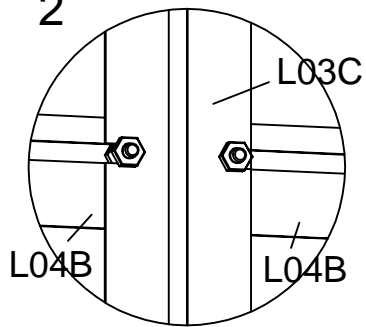

3

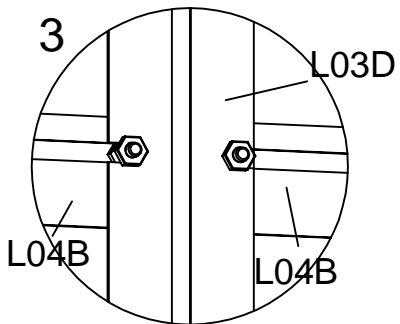

4

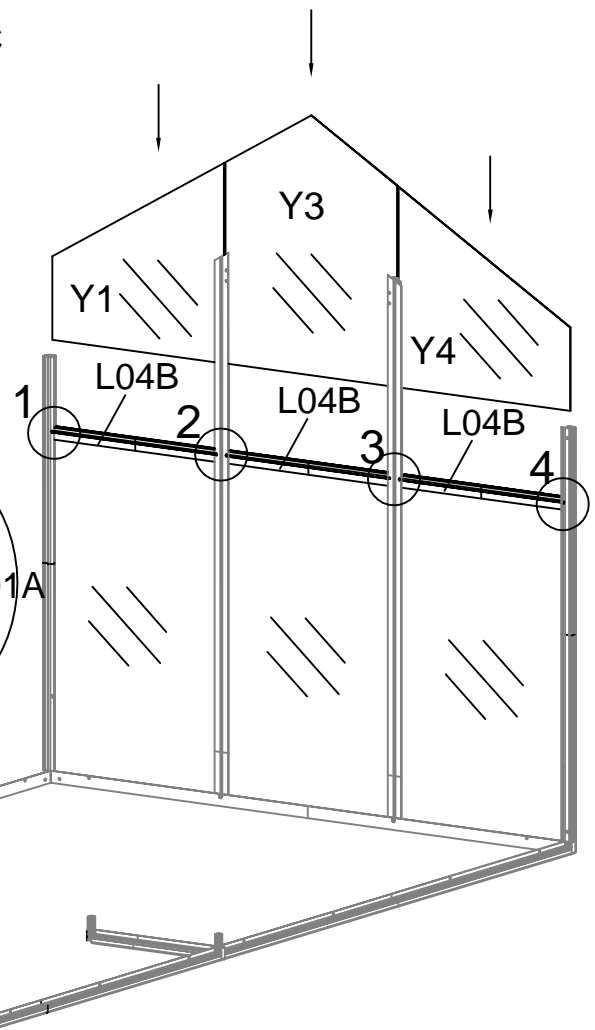
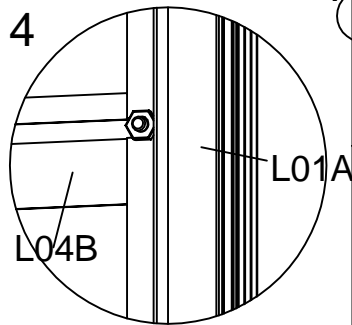

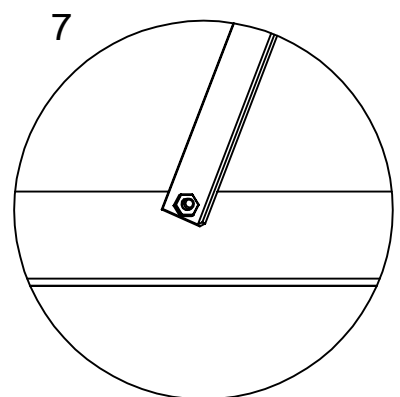
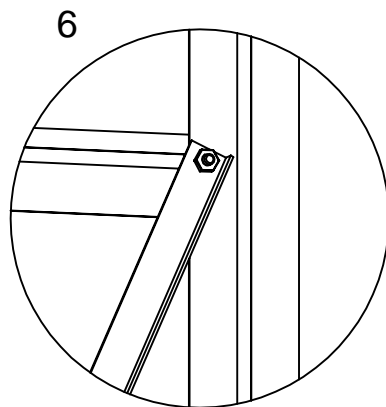
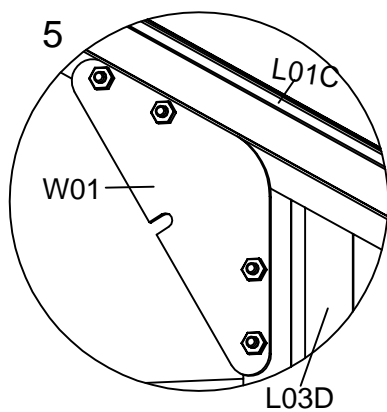
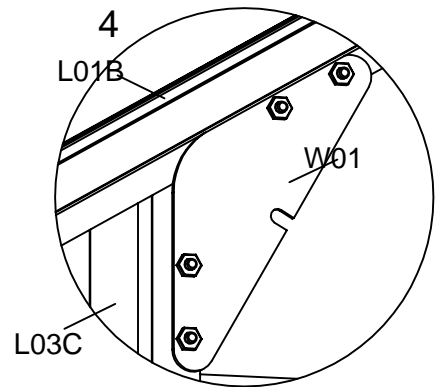
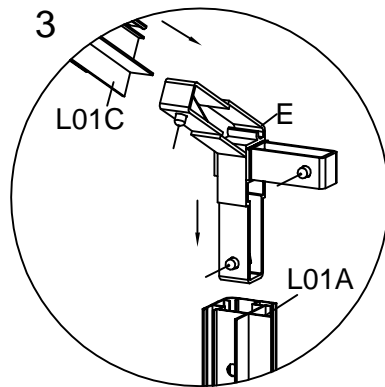
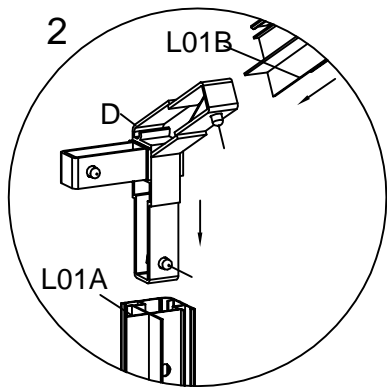
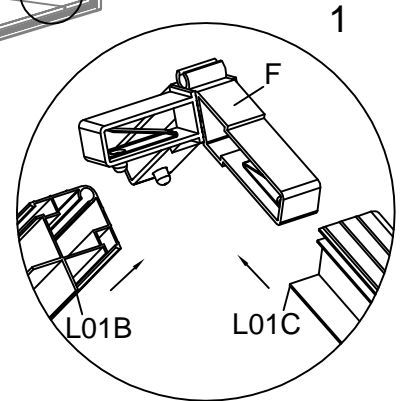
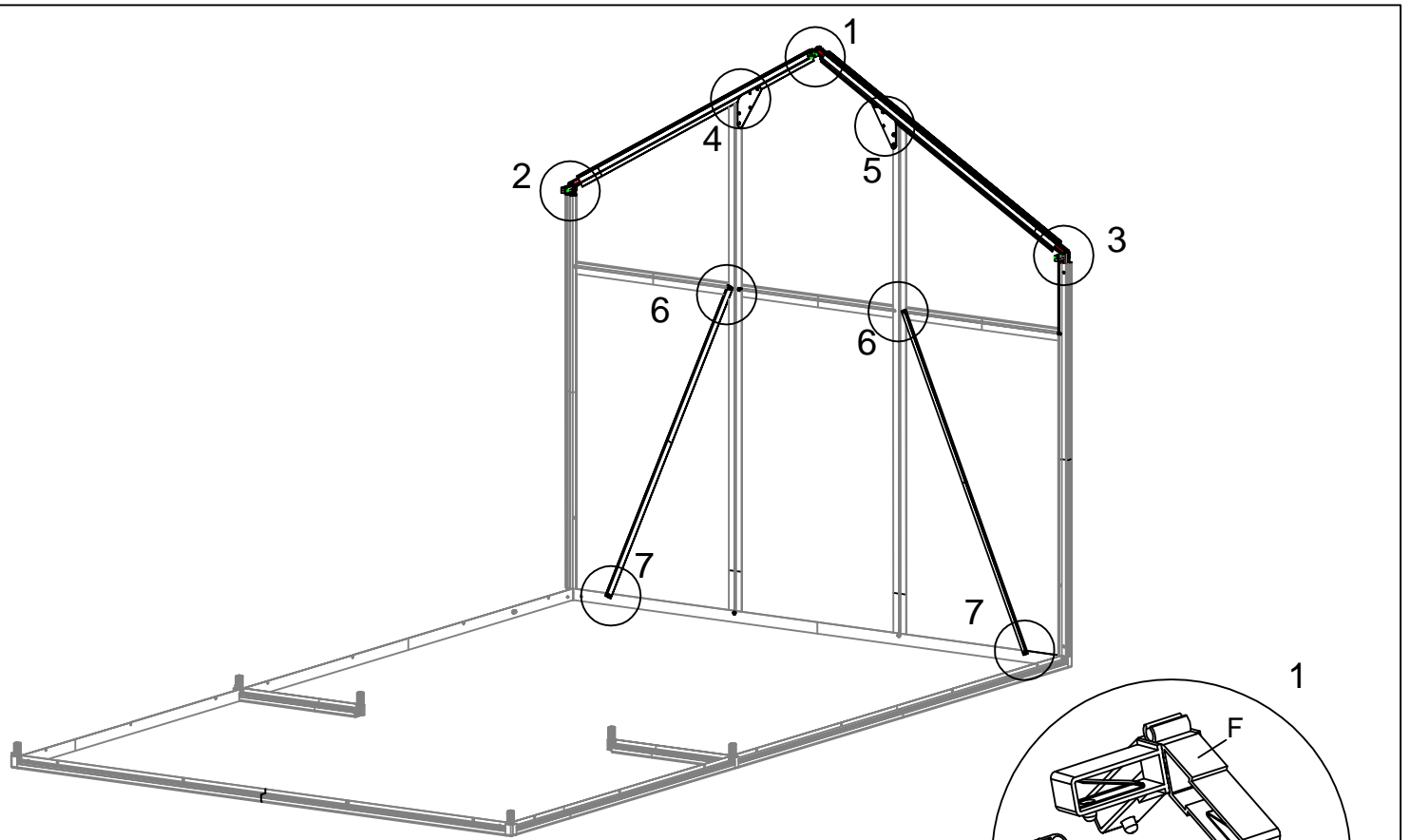

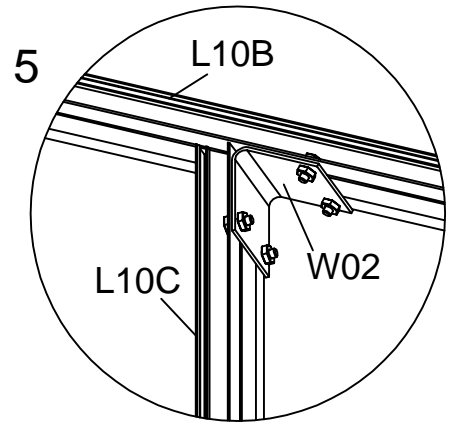
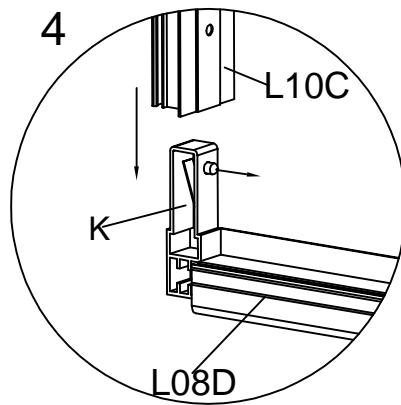
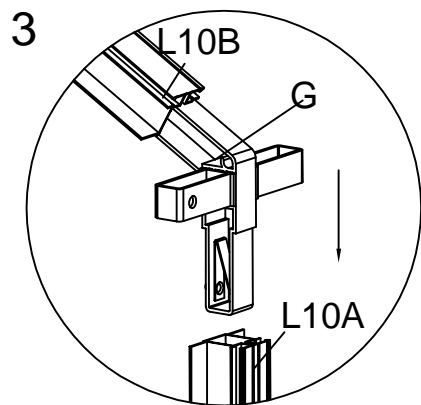
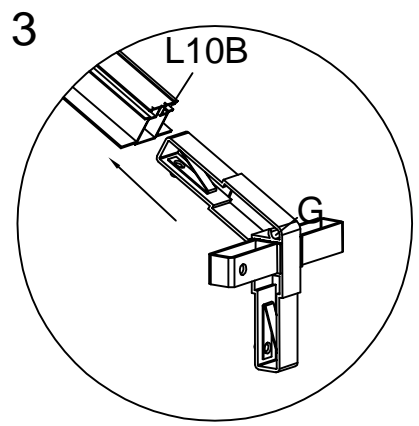
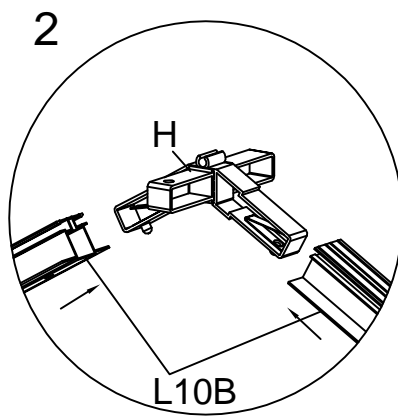
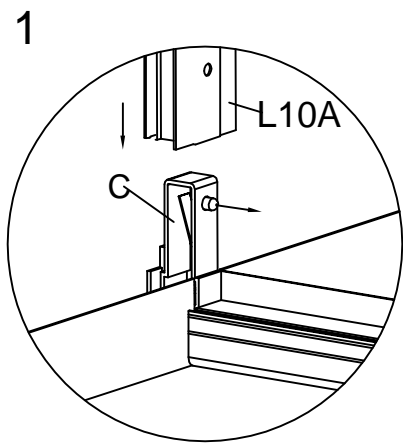
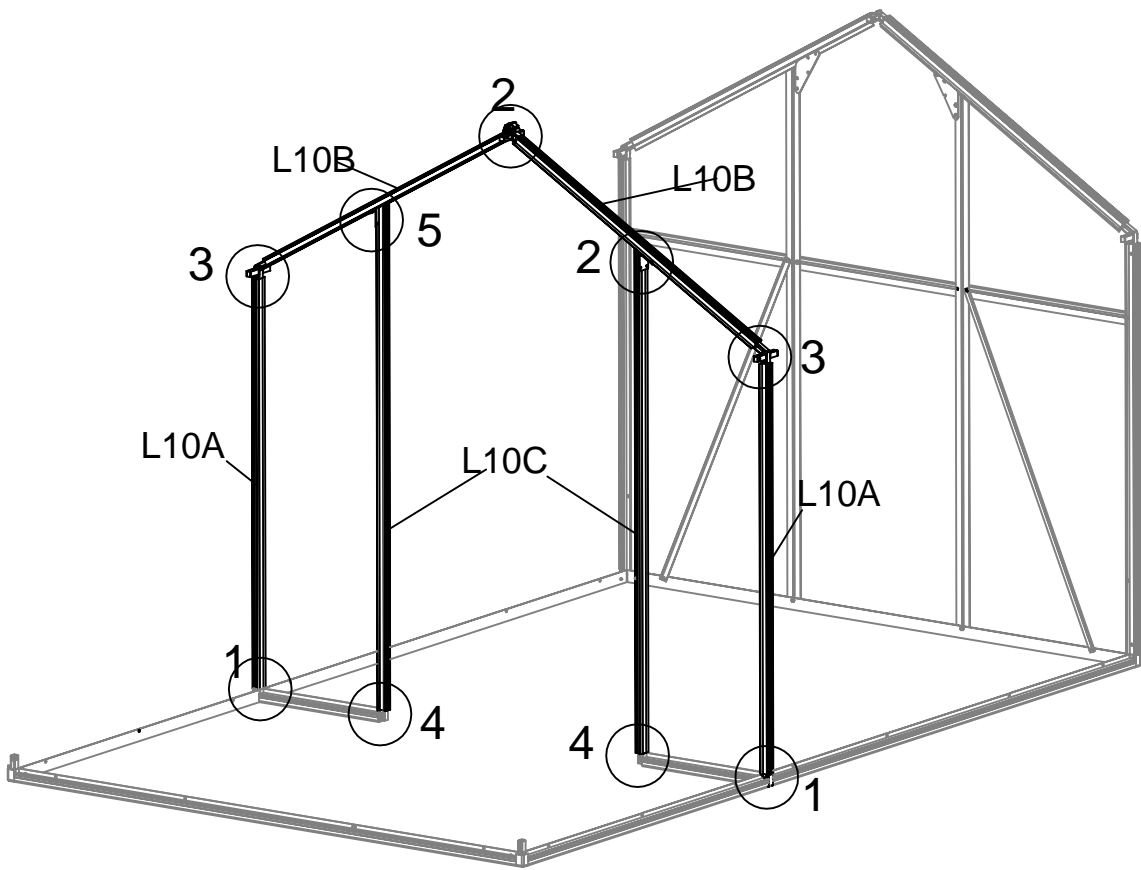

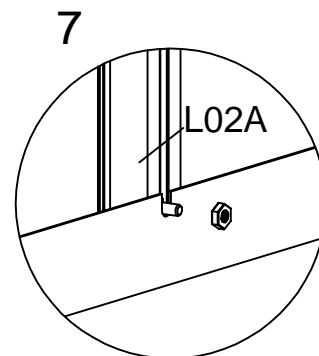
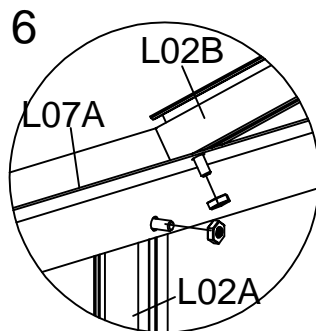
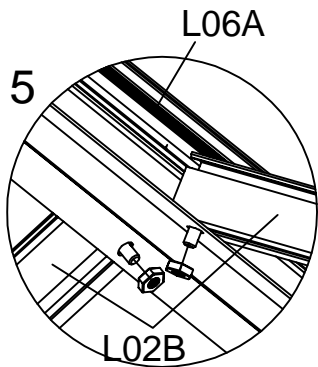
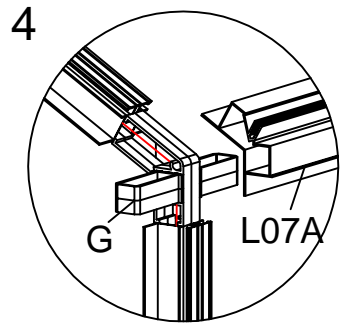
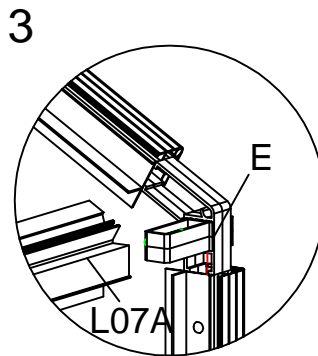
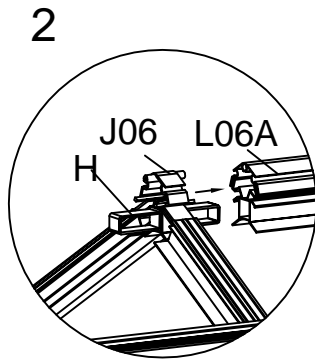
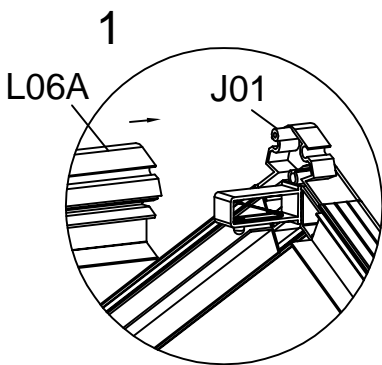
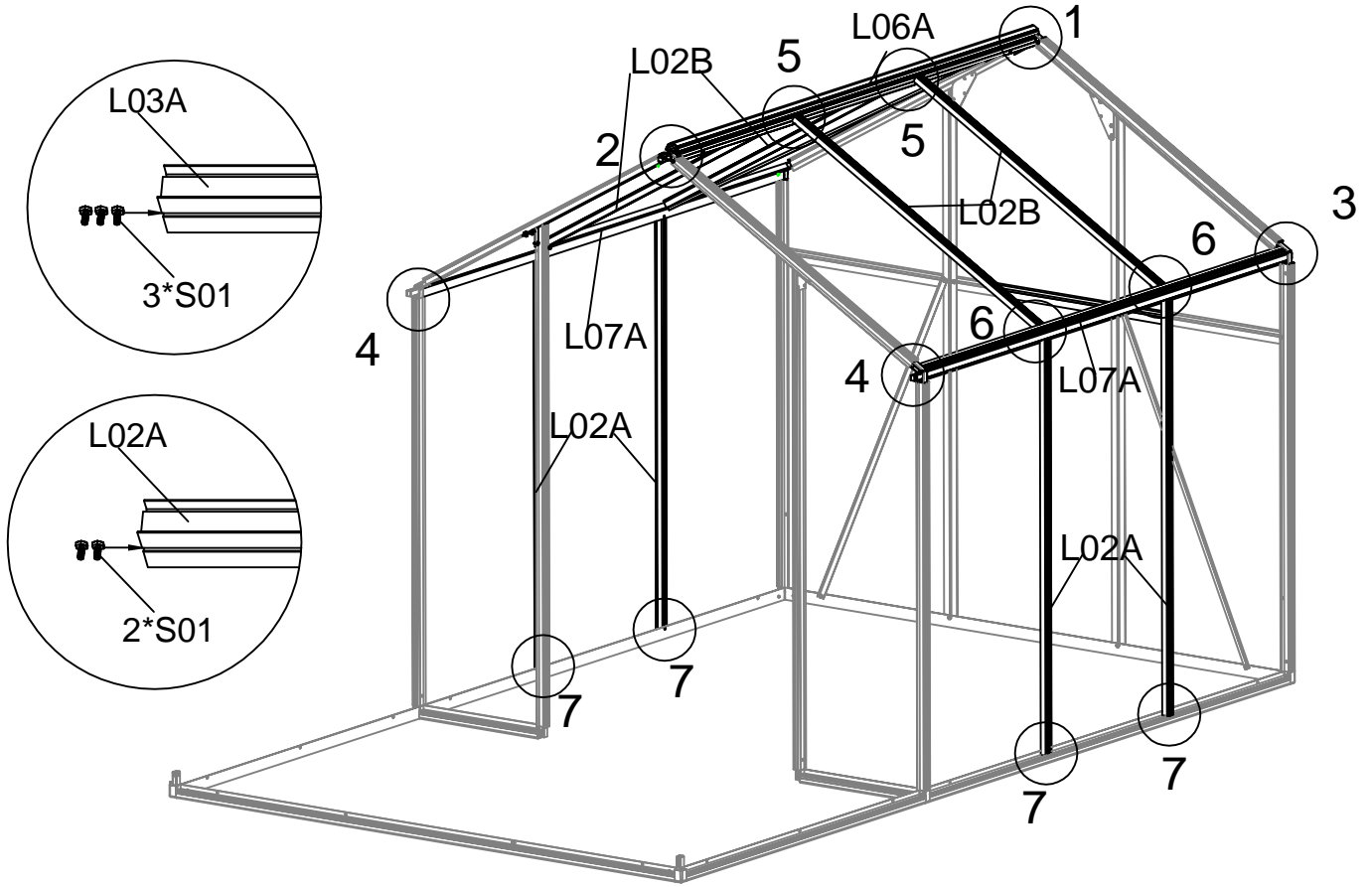

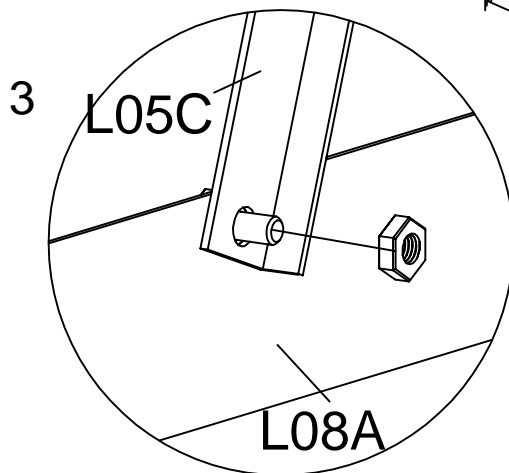
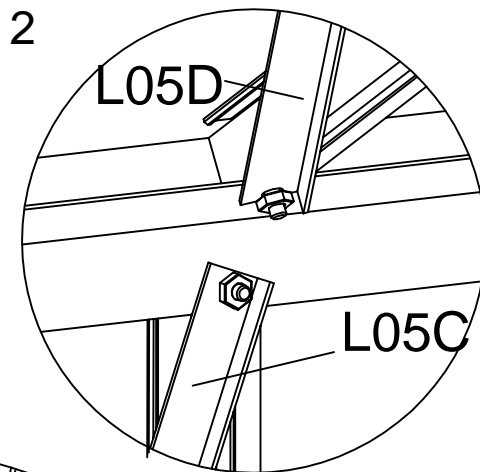
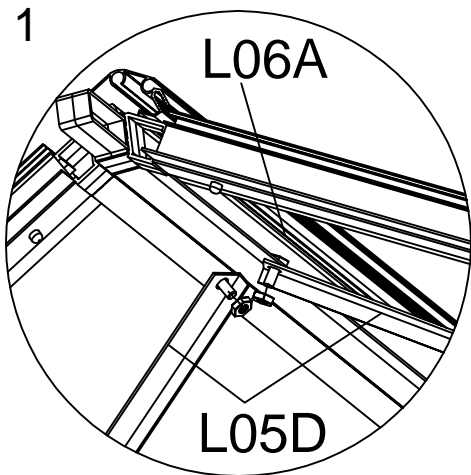
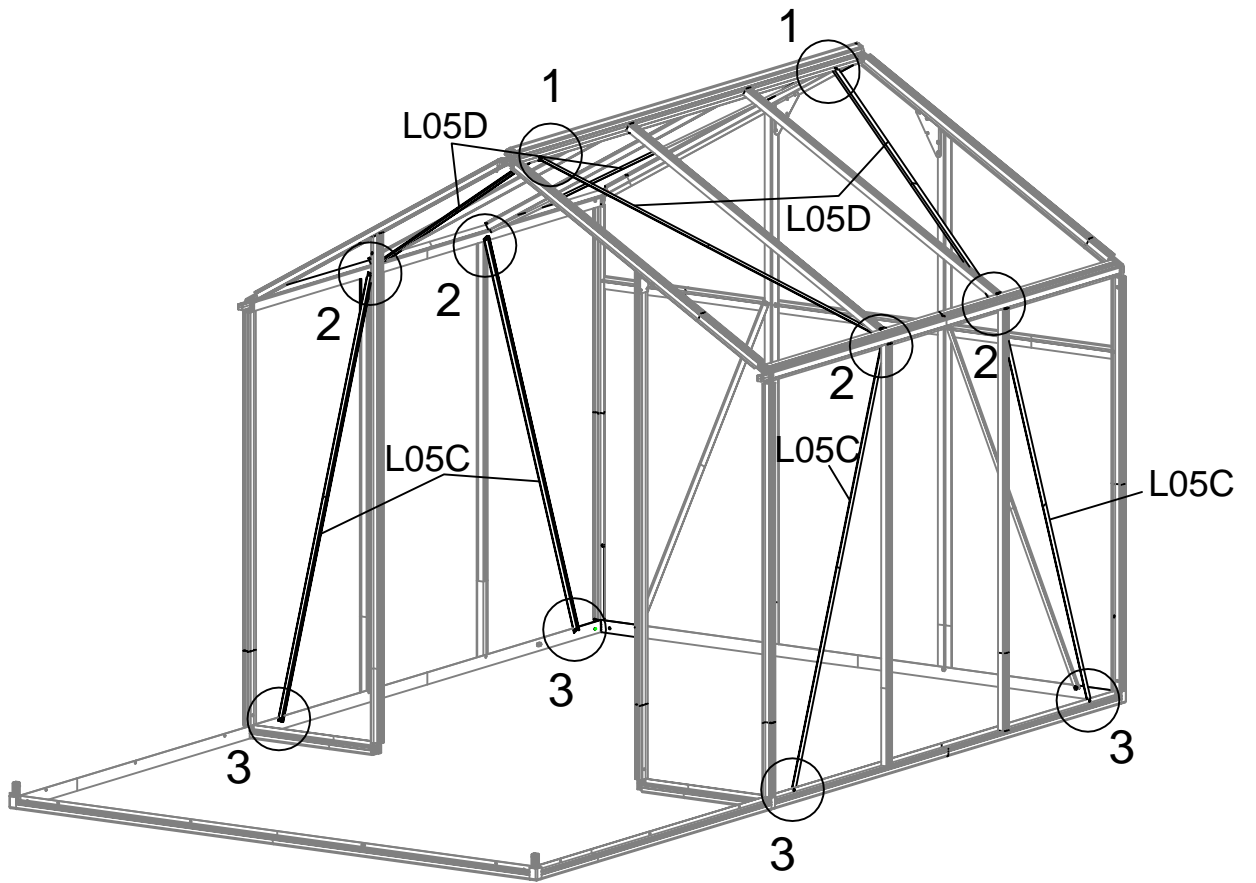

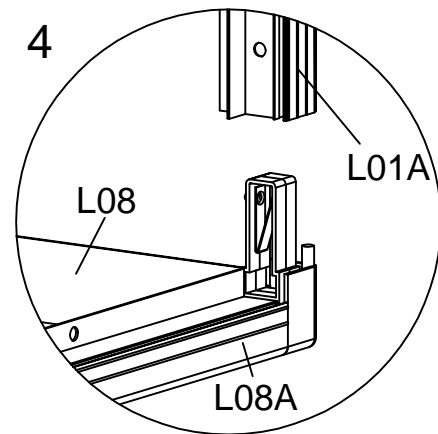
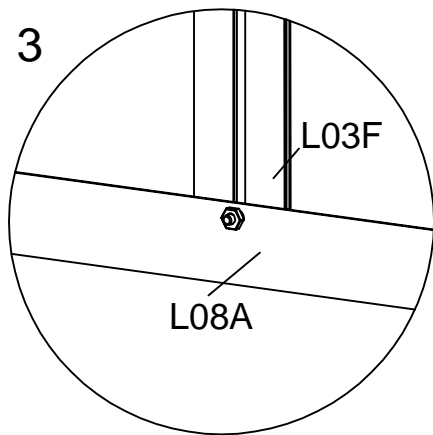
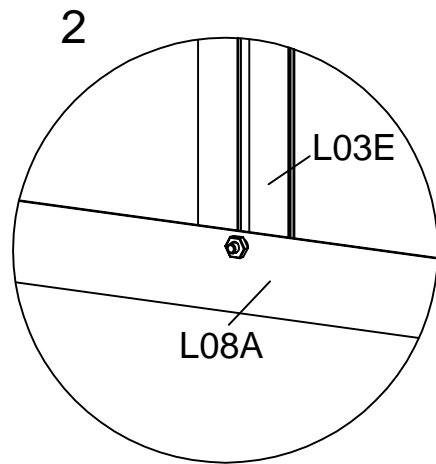
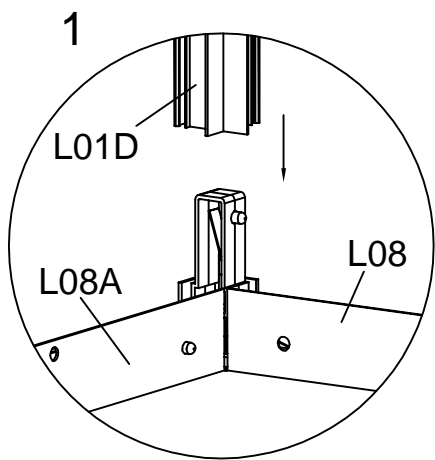
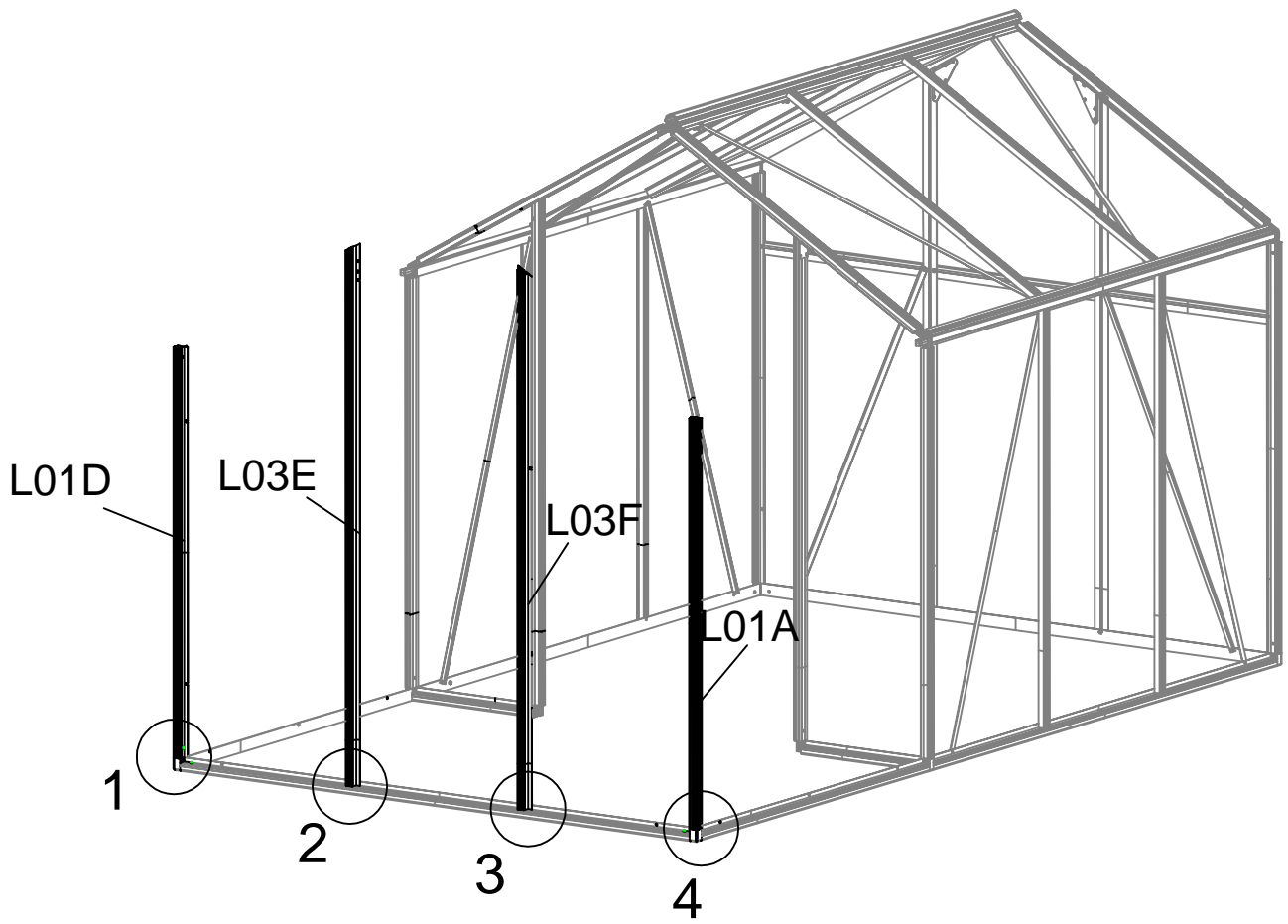

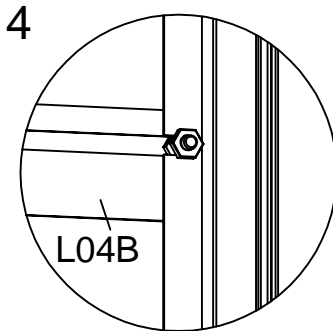
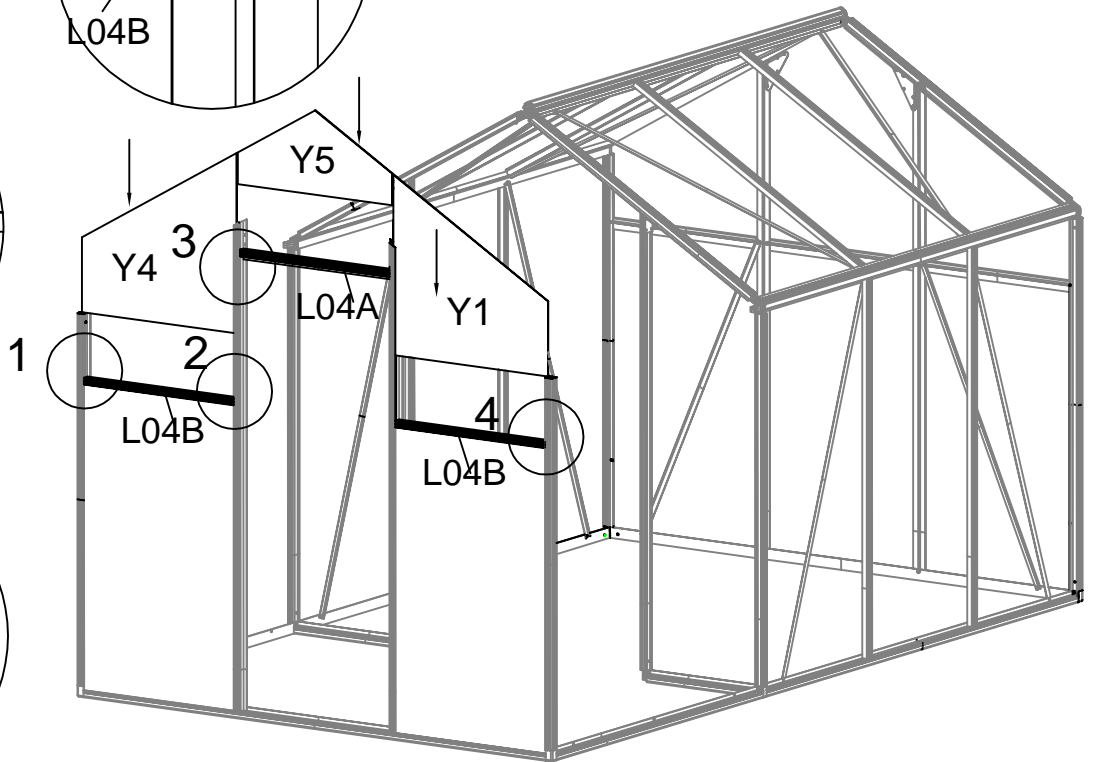
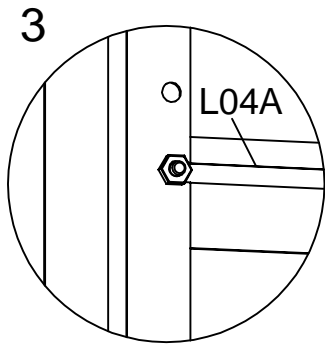
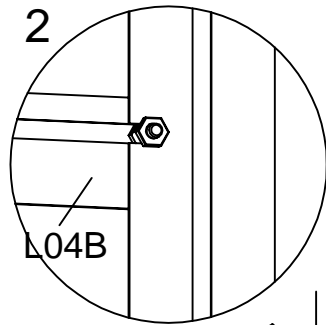
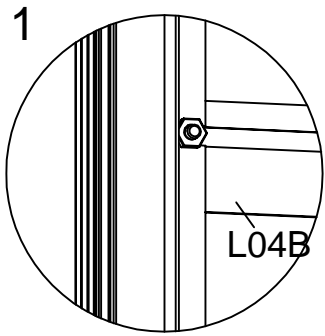
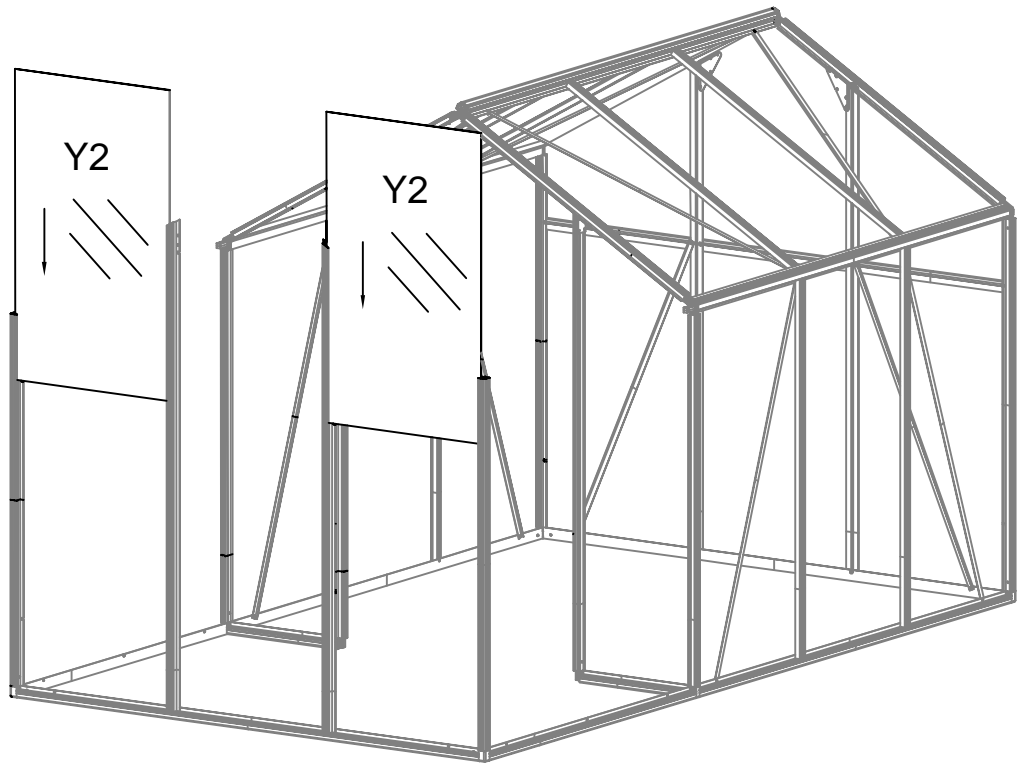

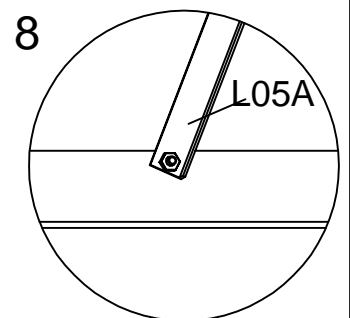
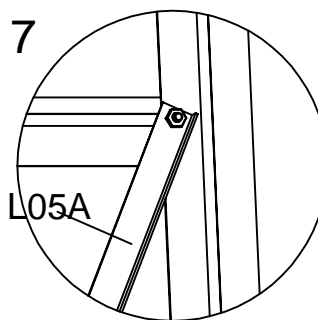
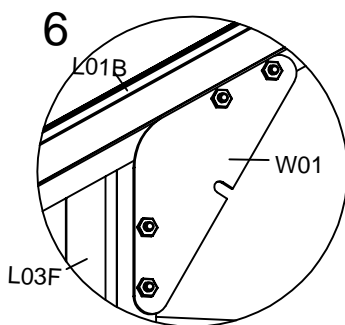
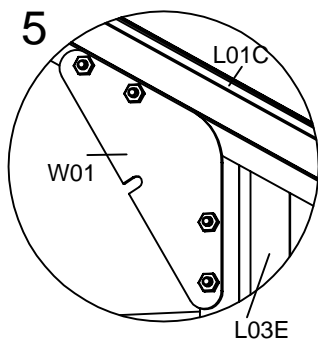
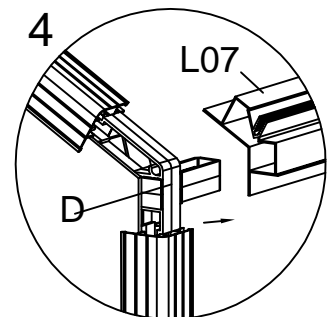
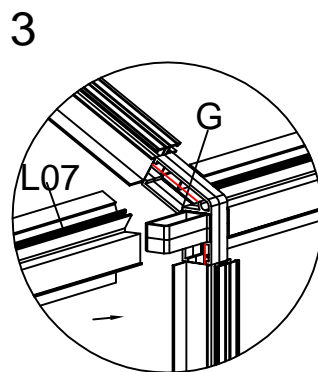
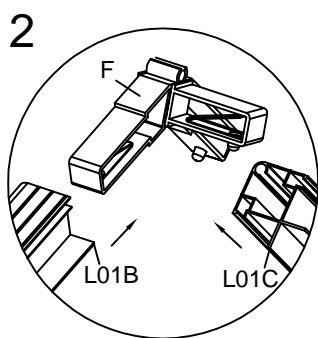
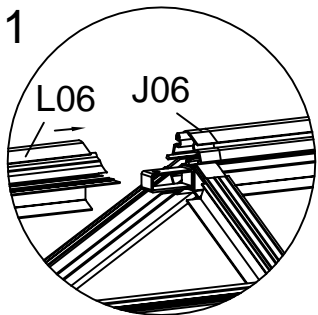
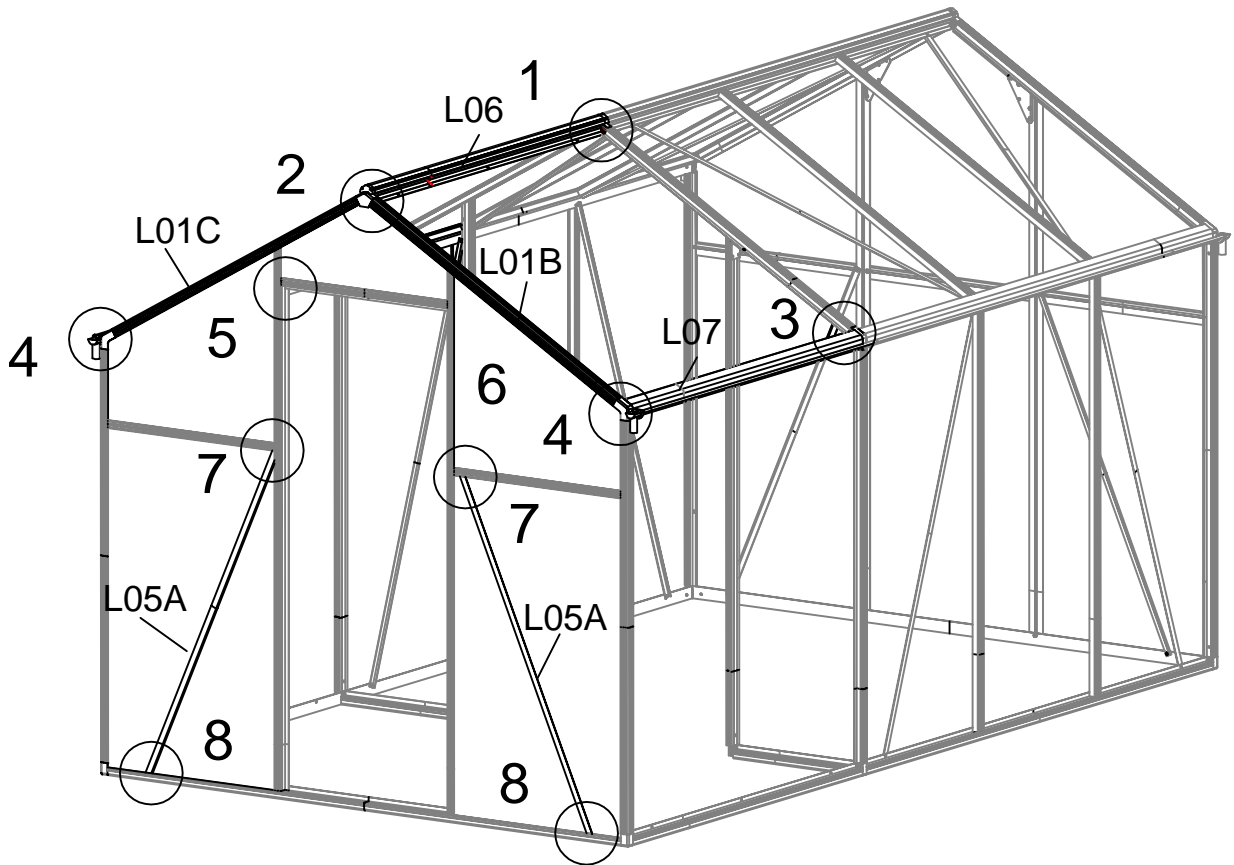

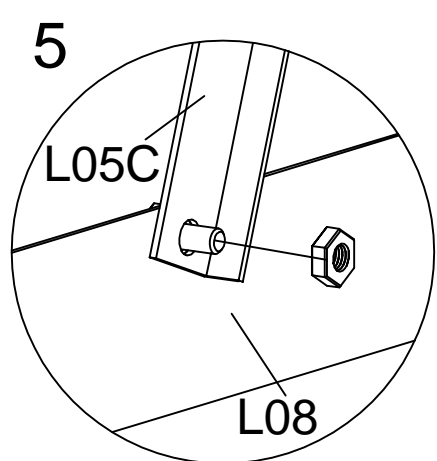
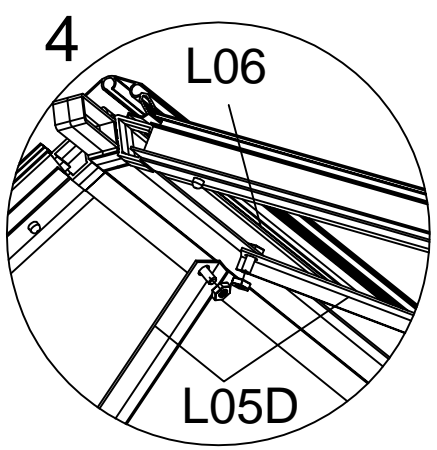
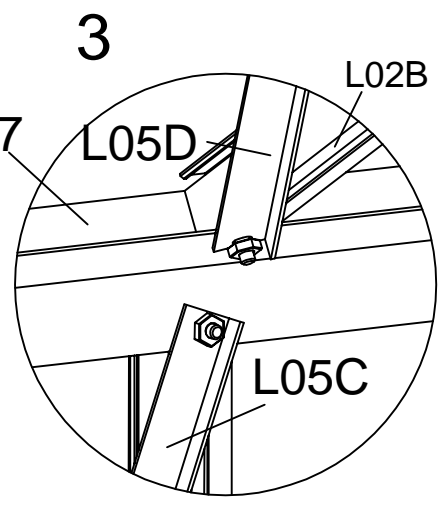
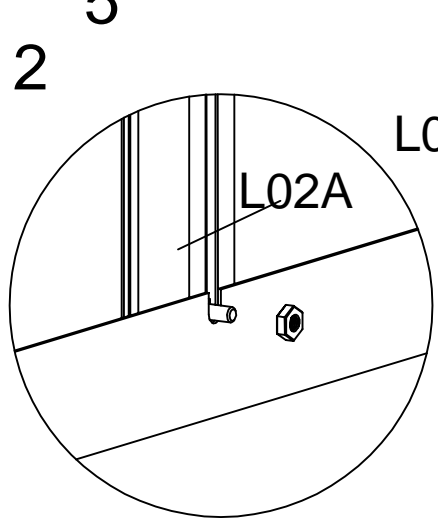
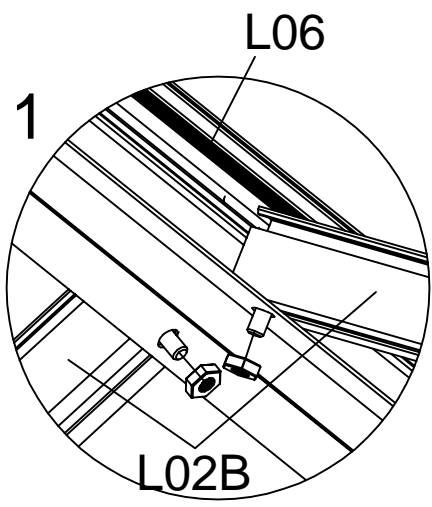
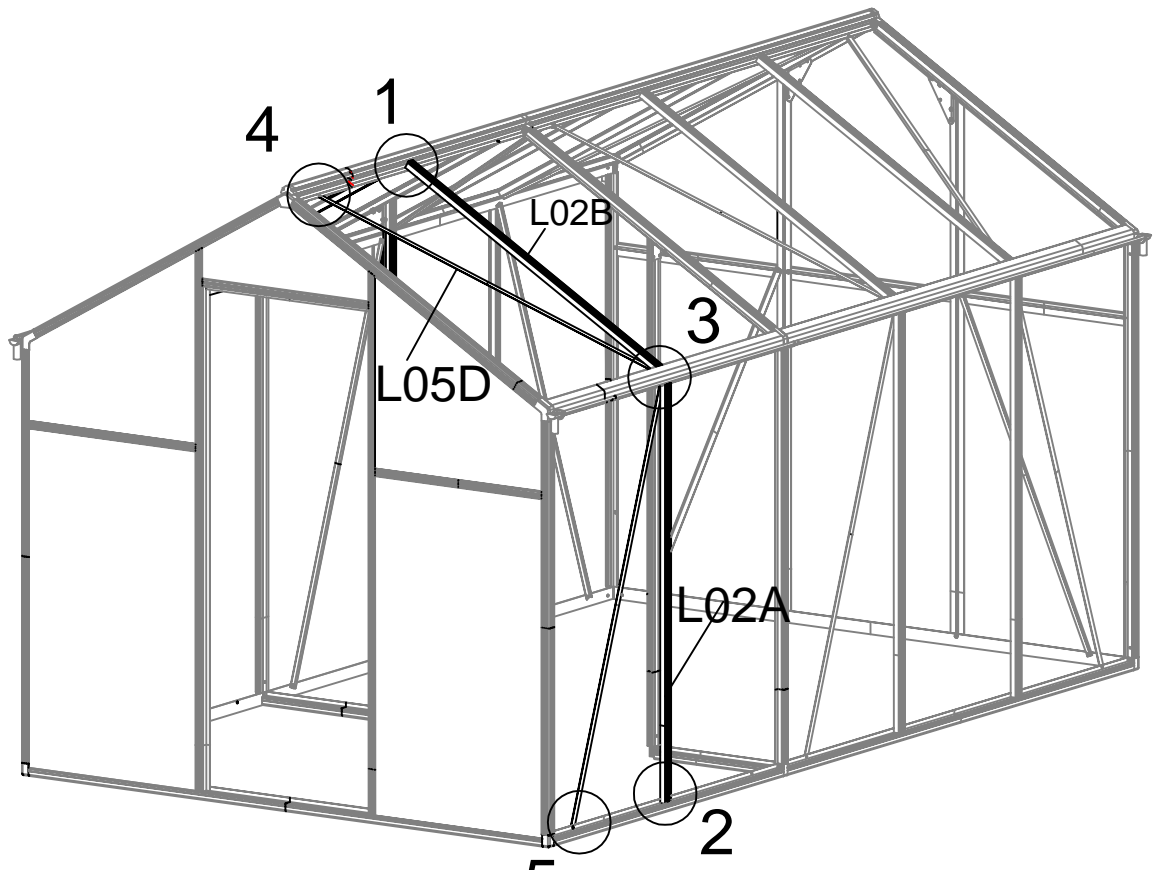

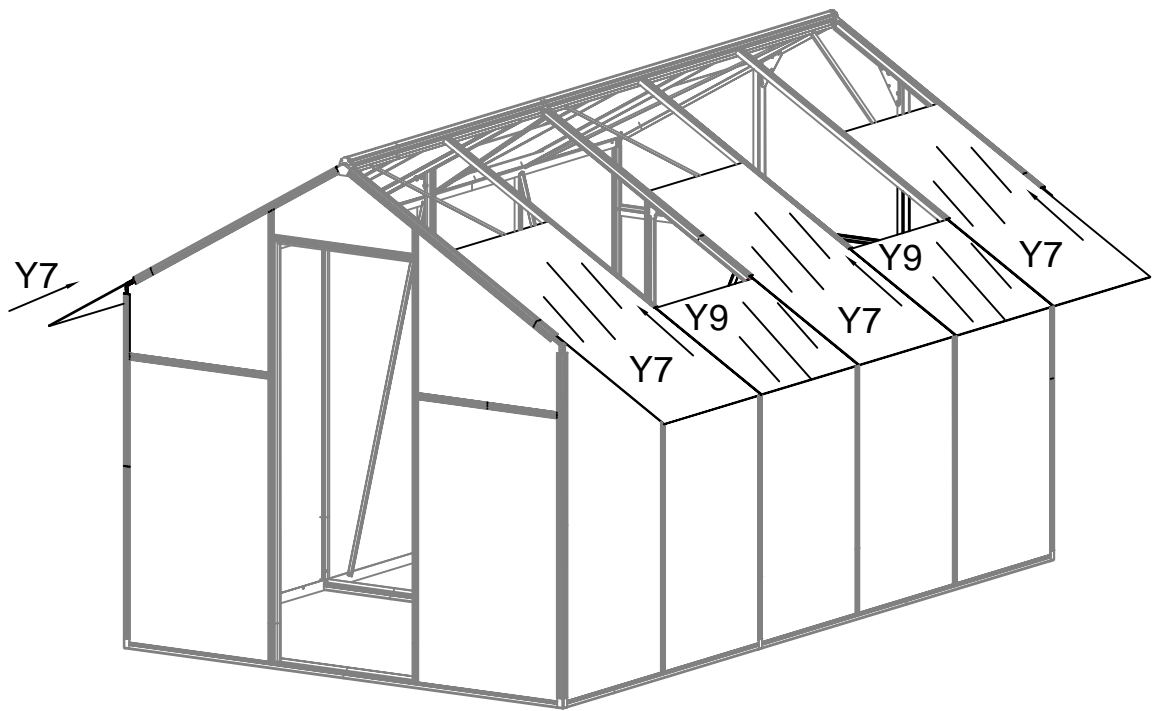
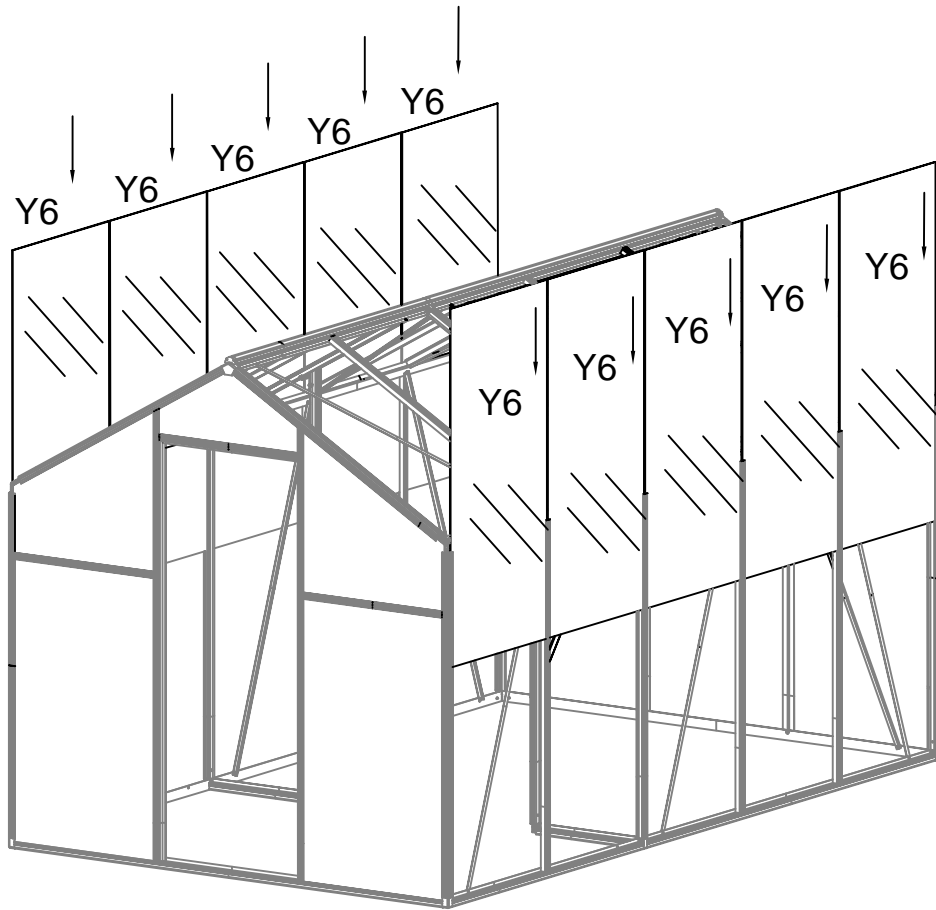

Roof Vent Assembly

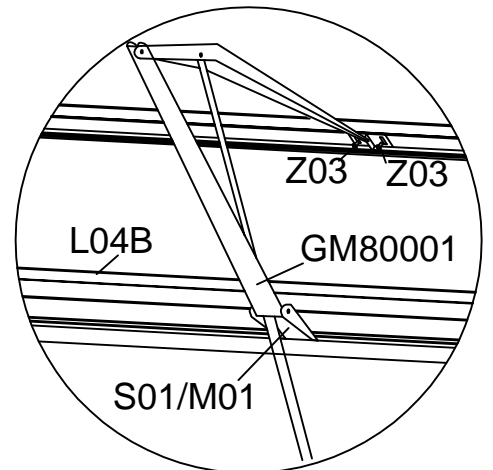
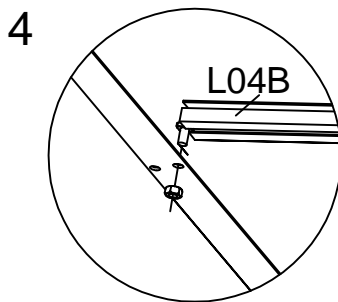
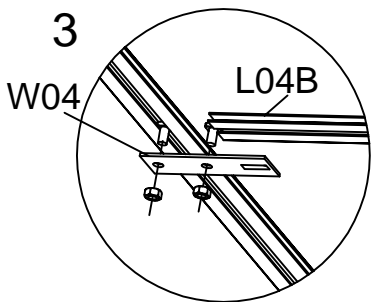
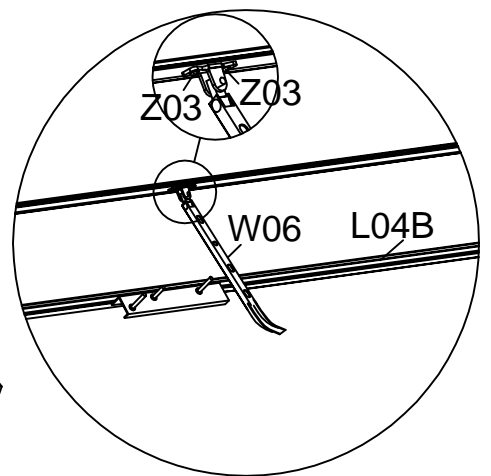
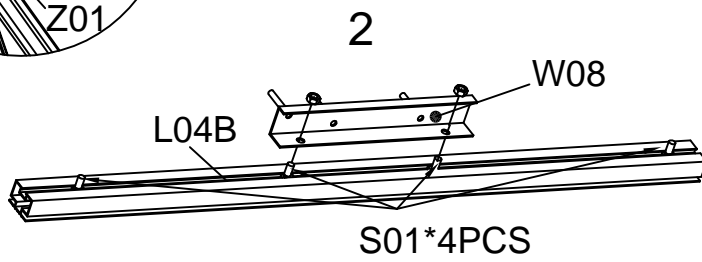
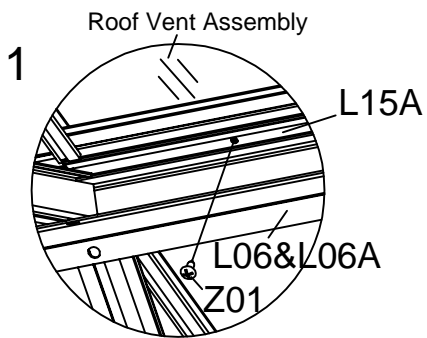
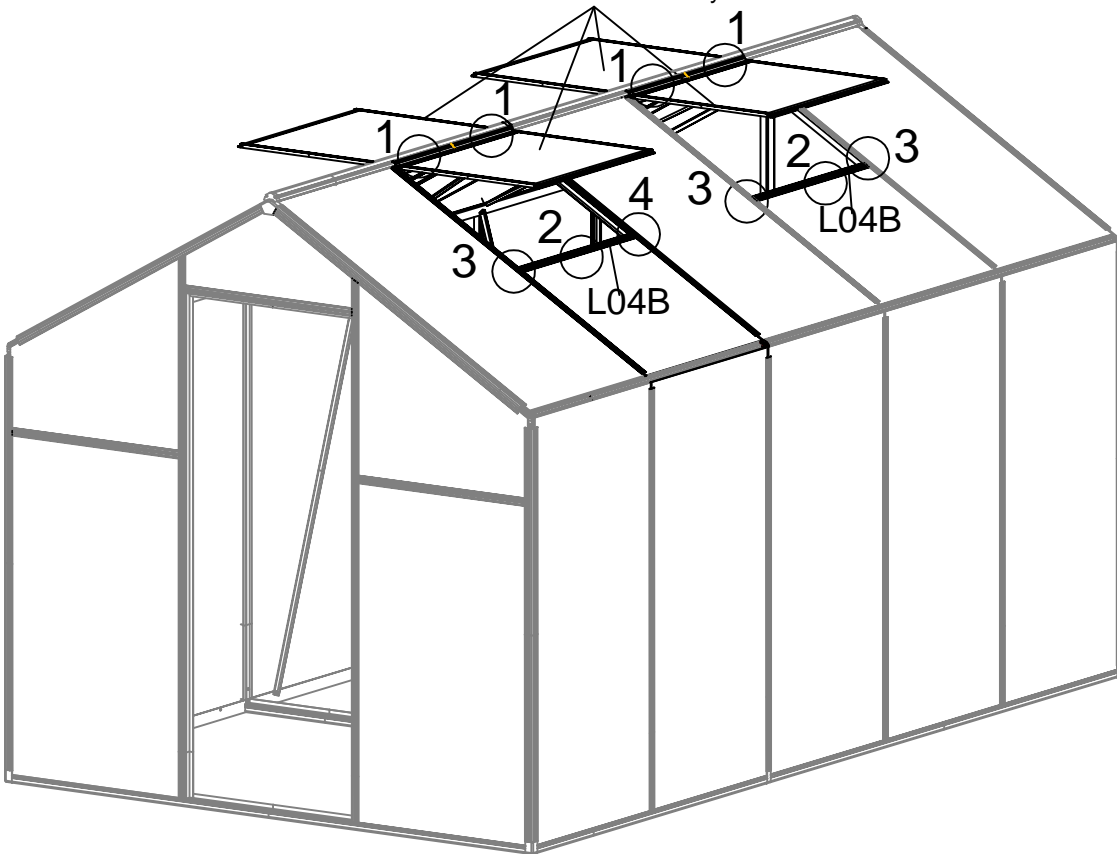

Door2 Assembly

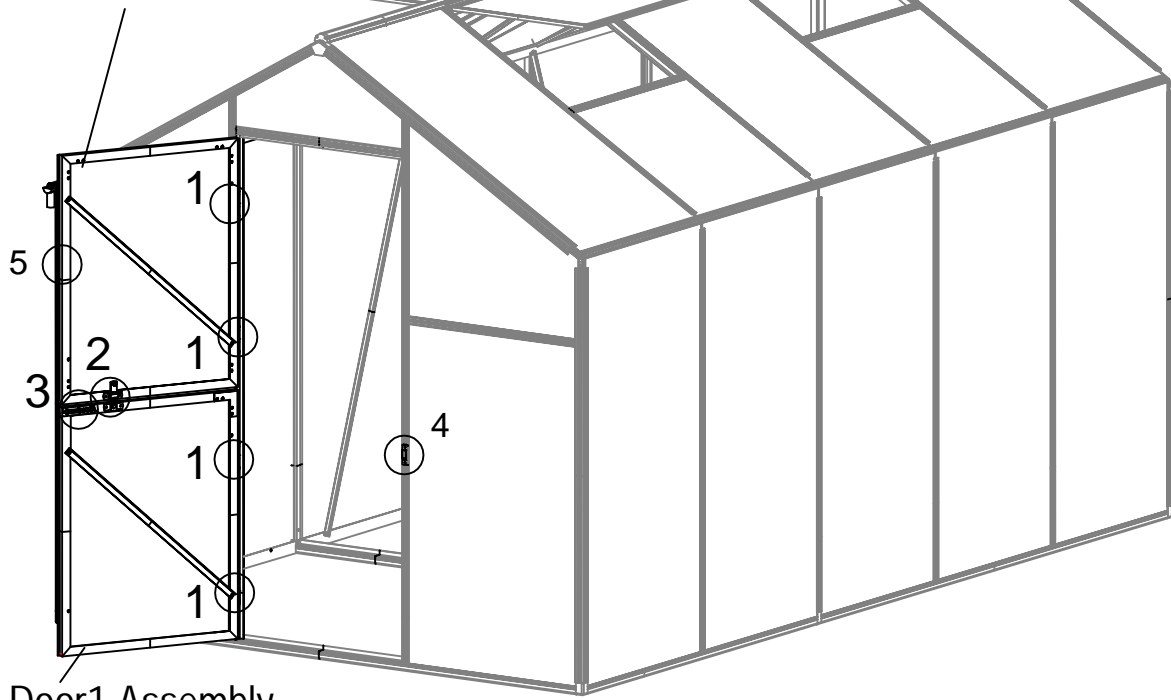

Door1 Assembly

