

Assembly instruction

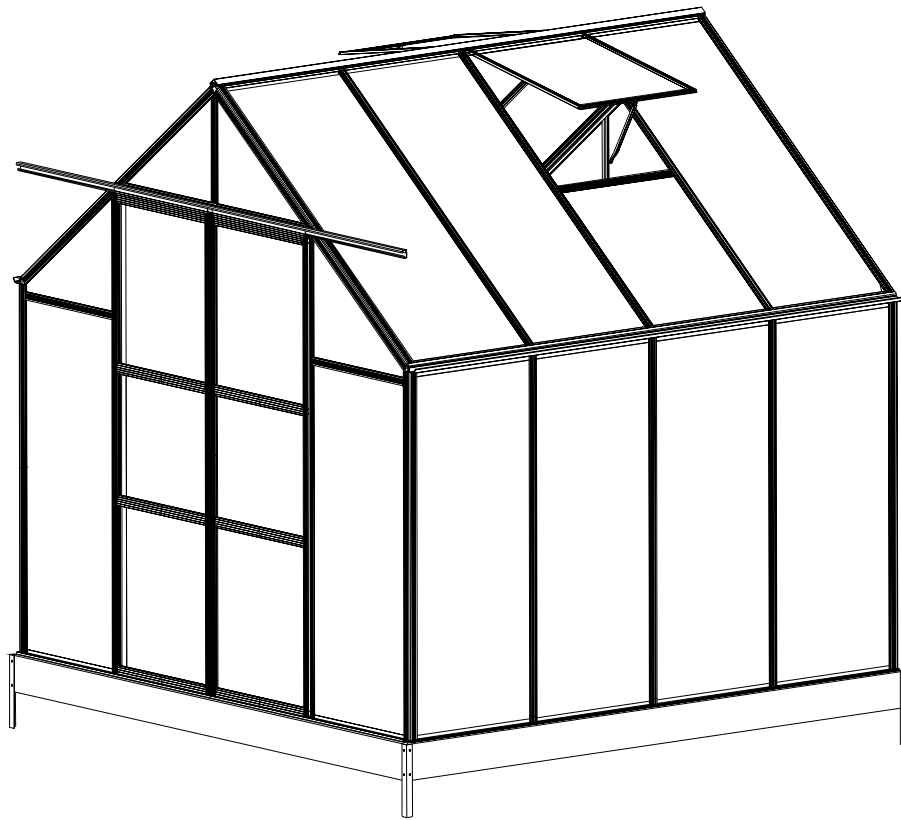

MODEL:GM31034

PRODUCT SIZE(LxWxH):258X257X205CM

PLEASE READ CAREFULLY BEFORE ASSEMBLY

Safety Warning & Advice

KEEP WORKING AREA CLEAN AND DRY

A cluttered, damp or wet working area may cause injuries.

PREPARE A FLAT AND LEVEL BASE

Make sure your greenhouse is located on a flat and level surface.

DO NOT INSTALL THE GREENHOUSE ON A WINDY DAY OR IN AN AREA SUBJECT TO HIGH WINDS

Although this greenhouse is designed to withstand greater wind loads than many other greenhouses, do not install it in on a windy day or in an area which is subject to high winds. A partially completed greenhouse may be seriously damaged if it is left in this state. It is your responsibility to safely and securely anchor the greenhouse, having regard to wind conditions in your area.

POLYCARBONATE SHEET



Remove approximately 2 inches of film from all sheet edges before installing and remove all film immediately after the construction is completed. Please ensure that the side with the white film faces outwards.

CHECK PARTS BEFORE ASSEMBLY

All parts have been well labelled. Please sort, separate and identify all components before construction and check against the parts list in this manual.

WARNING

Do not install this product when you are tired or distracted from the job at hand. We recommend that you use gloves during assembly.

Part	NO.	QTY.
	W05	15
	S01 M6X10	16
	M01 M6	16

Skip this step if you don't take the base.

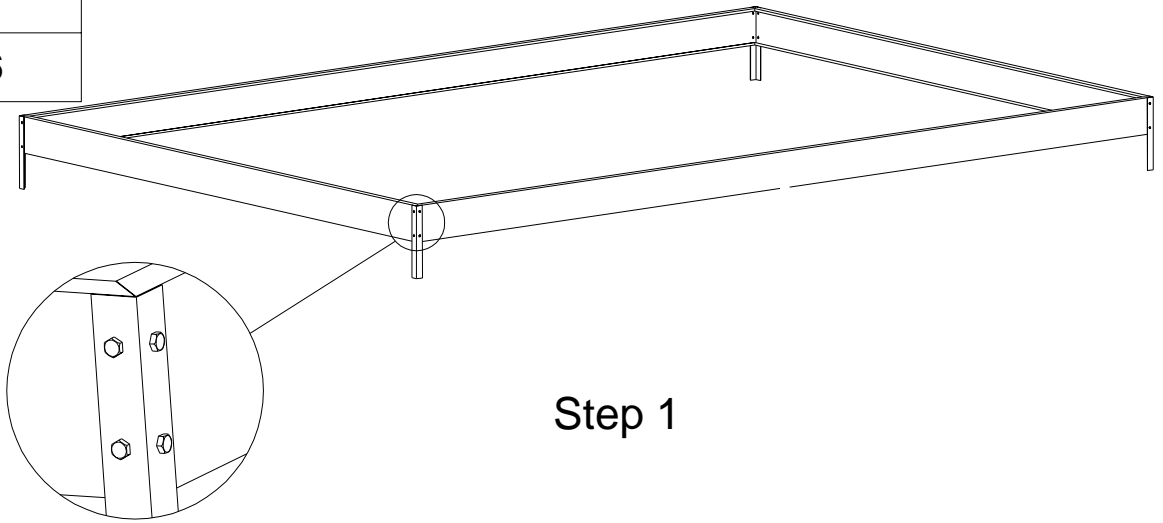

Step 1

When fixing the greenhouse to the base please loosen the existing greenhouse bolts and fasten the W05 clips. No extra nuts or bolts are needed.

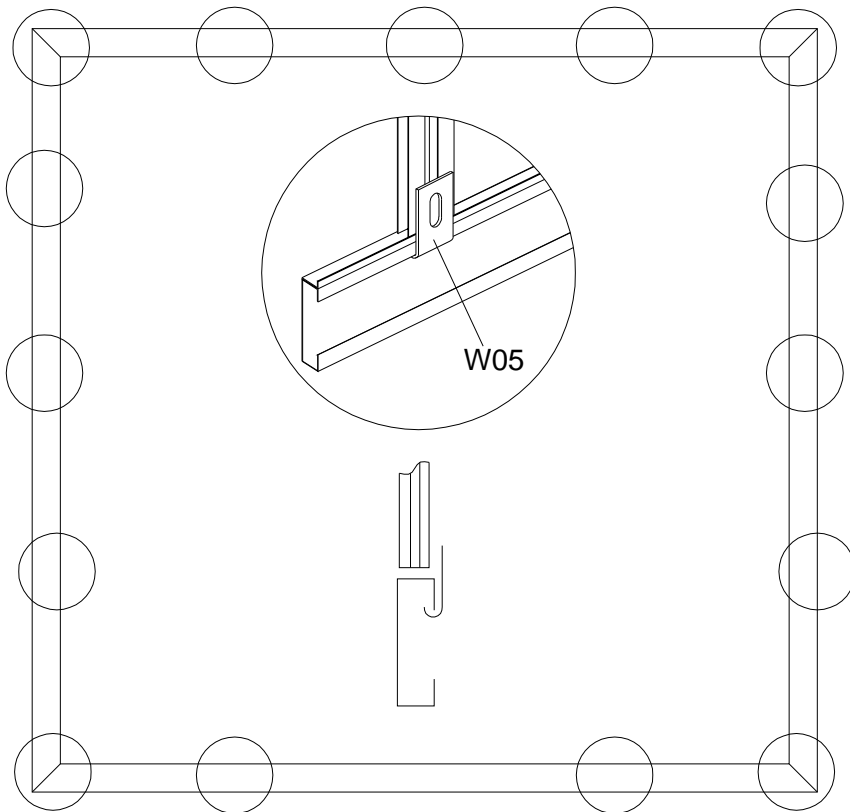

Step 2

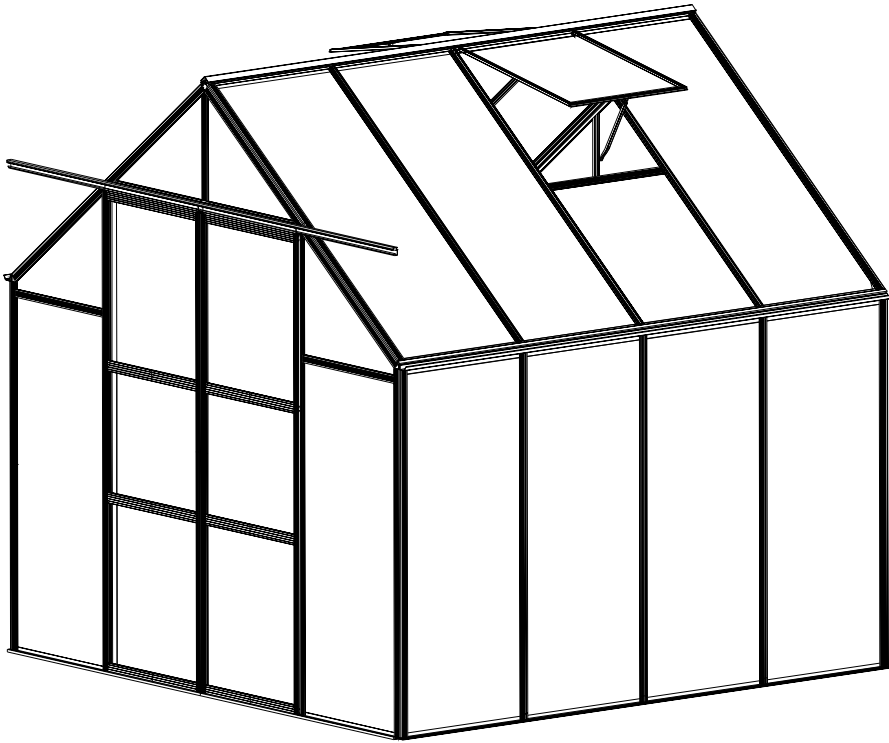



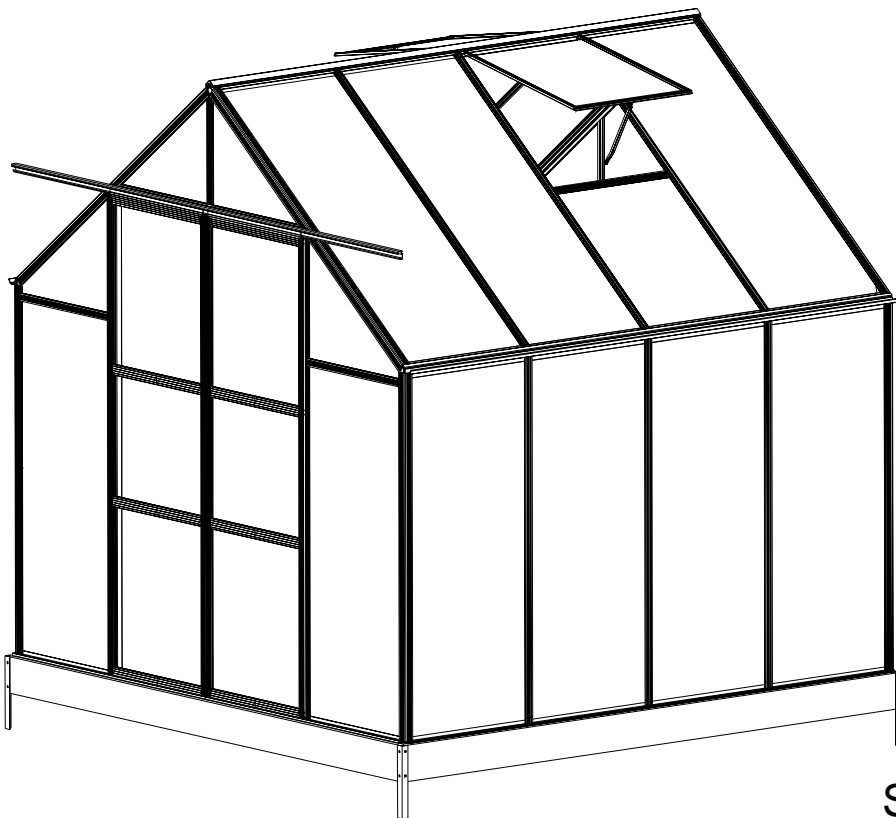
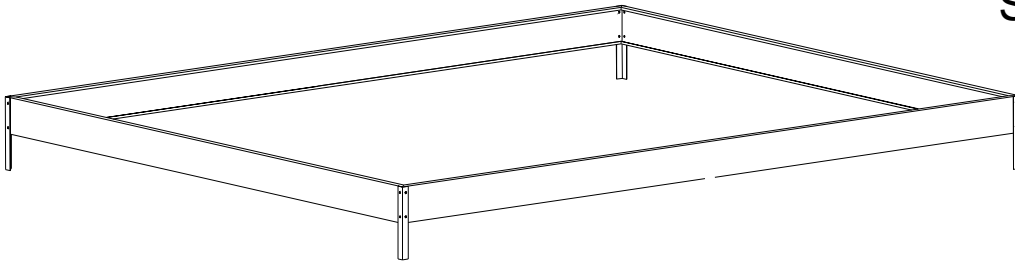

Step 3





Step 4











P2 -P3Door Assembly

Part	NO.	QTY.
	L18A	4
	L15	2
	L16A	1
	L16B	3
	L17	2













P4 Vent Assembly

Part	NO.	QTY.
	L19	4
	L20	2
	L21	2











(P5-P7) Rear Wall

Part	NO.	QTY.
	L01A	1
	L01B	1
	L01C	2
	L03B	4
	L02C	1
	L02D	1
	L02E	1
	L05A	2
	L08A	1
	L09	1















(P8-P11) Front Wall

Part	NO.	QTY.
	L01A	1
	L01B	1
	L01D	1
	L01E	1
	L03A	1
	L03B	2
	L03T	1
	L04A	1
	L04B	1
	L05A	2
	L05B	2
	L10	1
	L14	1













(P12-P23) Sides and Roof

Part	NO.	QTY.
	L02A	6
	L02B	6
	L03B	2
	L05C	4
	L05D	4
	L05E	3
	L05F	6
	L06	1
	L07	2
	L08B	2

PARTS

Part	NO.	QTY.
	W06	2
	W08	2
	W01	2
	W02	4
	W03	2
	W04	7
	S02 M6X20	2
	M01 M6	112
	S01 M6X10	110
	Z01 Ø4X16	32
	Z02 Ø4X14D	8
	Z03 Ø4X10	6
	J01	2
	J02L/R	2/2
	J03L/R	1/1
	J04	1

Polycarbonate

Part	NO.	QTY.
	Y1	2
	Y2	6
	Y3	1
	Y4	2
	Y5	1
	Y6	8
	Y7	6
	Y8	1
	Y9	2
	Y10	2
	Y11	4
	Y12	2
	Y13	1

Part	NO.	QTY.
	L18A	4
	L15	2
	L16A	1
	L16B	3
	L17	2

(P2-P3) Door Assembly

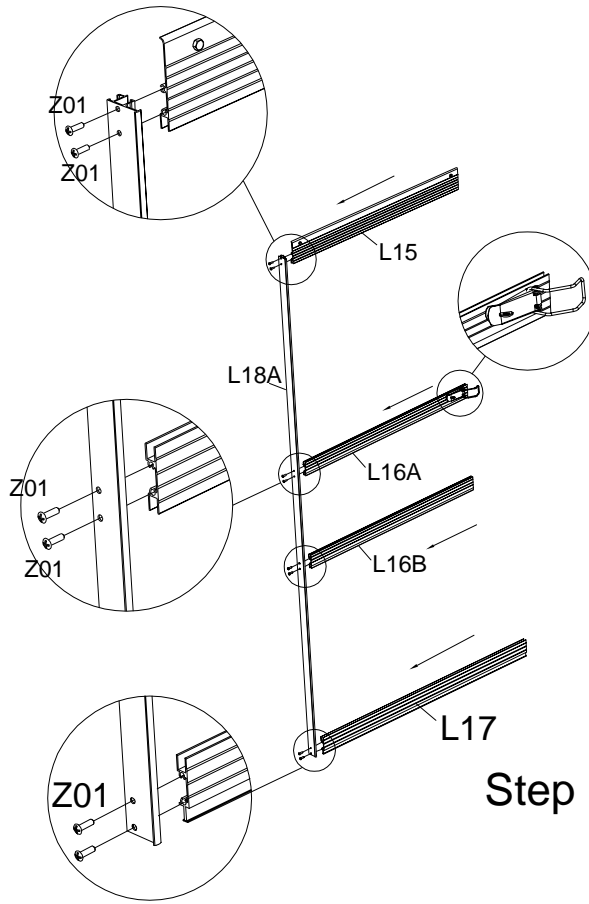

Step 1-1

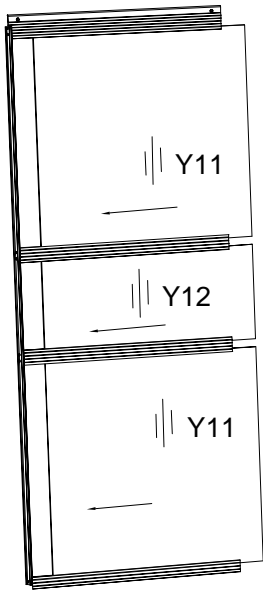

Step 1-2

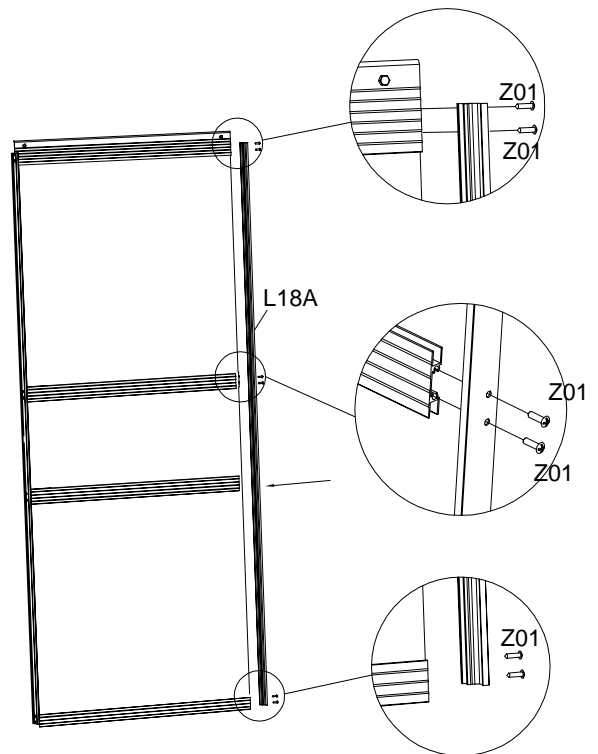

Step 1-3

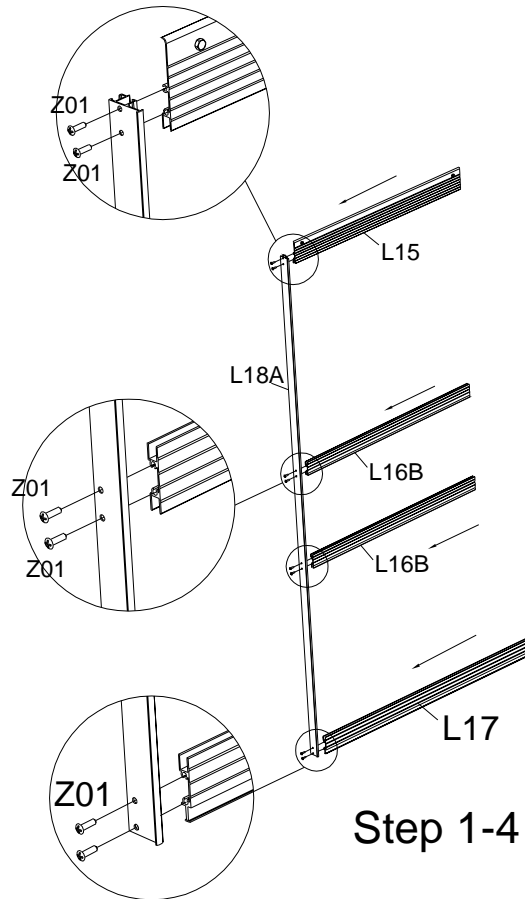

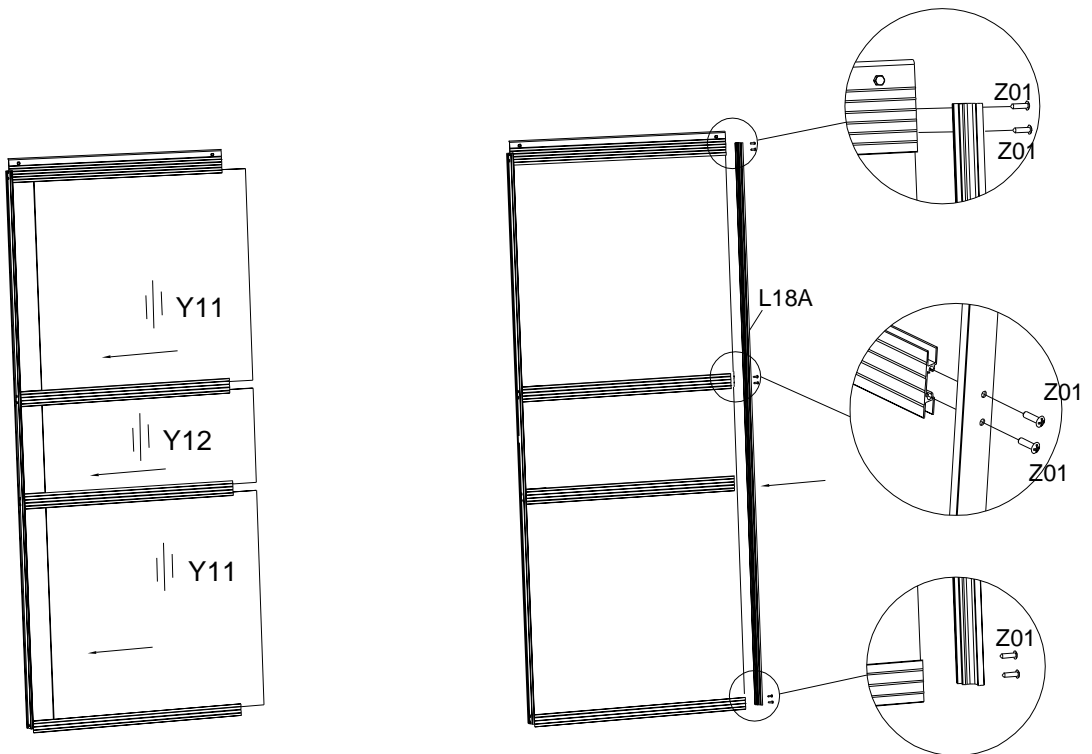

Step 1-4



Step 1-5

Step 1-6

Part	NO.	QTY.
	L19	8
	L20	4
	L21	4

P4 Vent Assembly

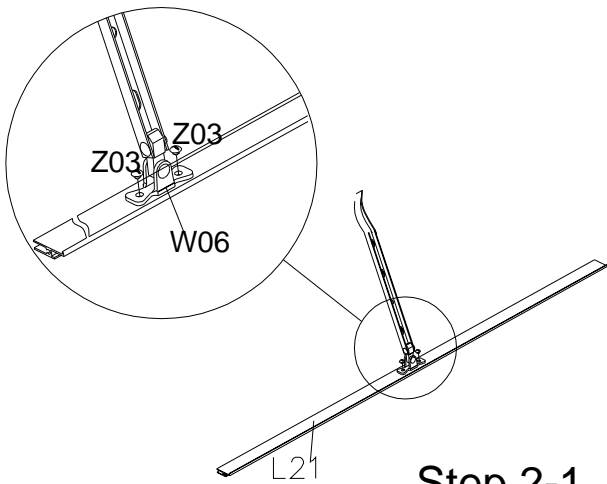
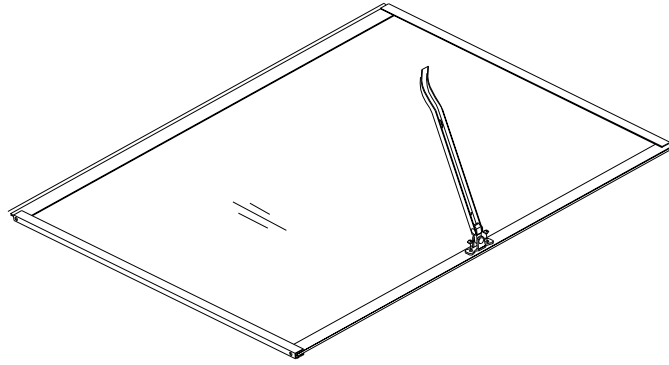



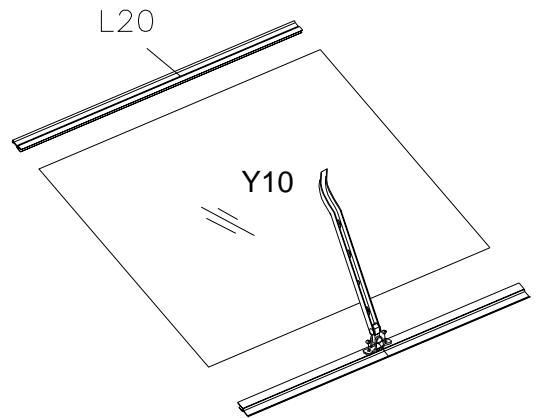



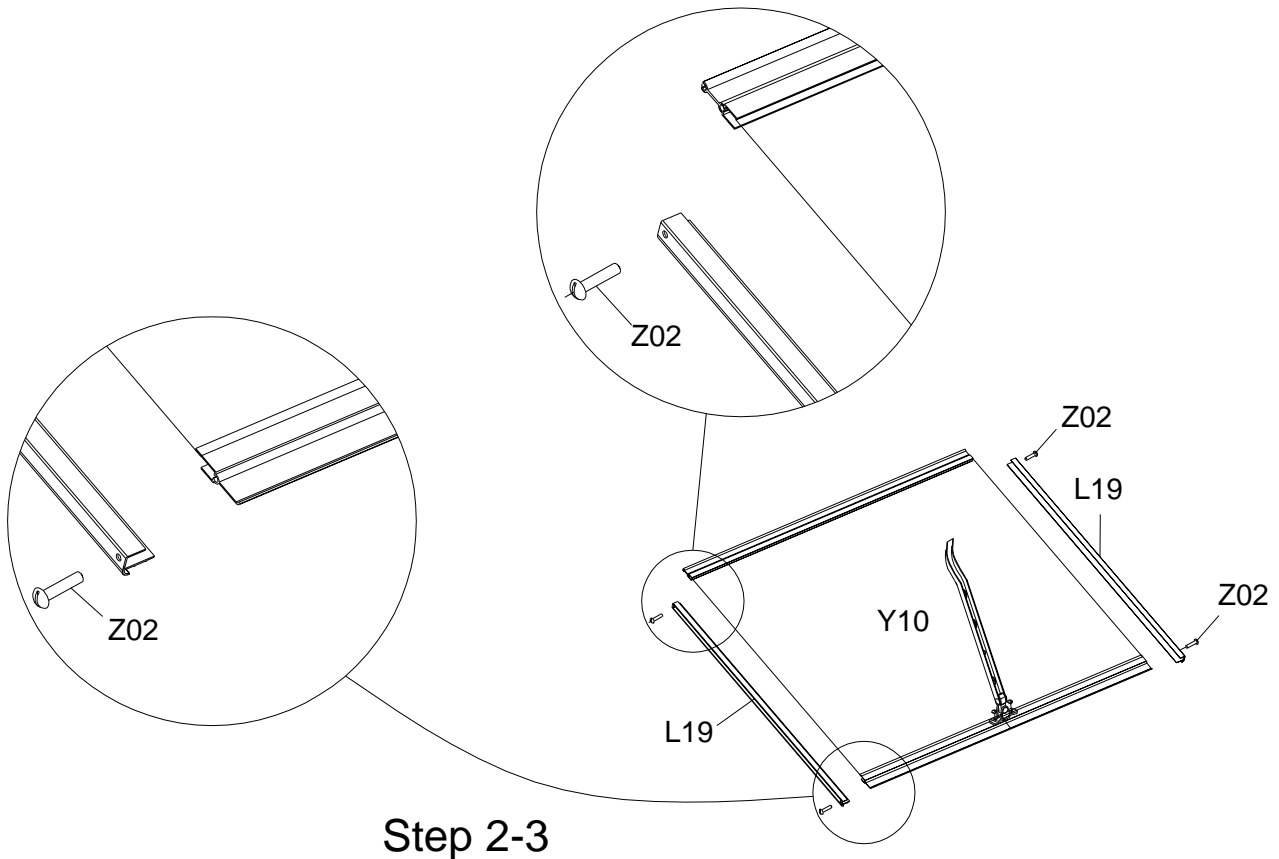



Step 2-1



Step 2-2



Step 2-3

Part	NO.	QTY.
	L01A	1
	L01B	1
	L01C	2
	L03B	4
	L02C	1
	L02D	1
	L02E	1
	L05A	2
	L08A	1
	L09	1

(P5-P7) Rear Wall

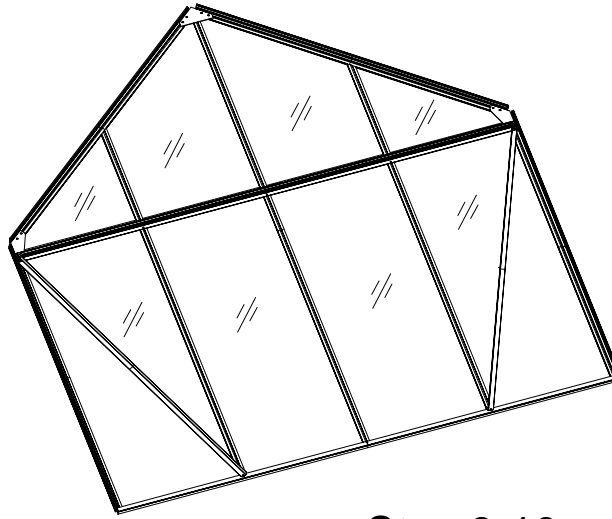

Step 3-10

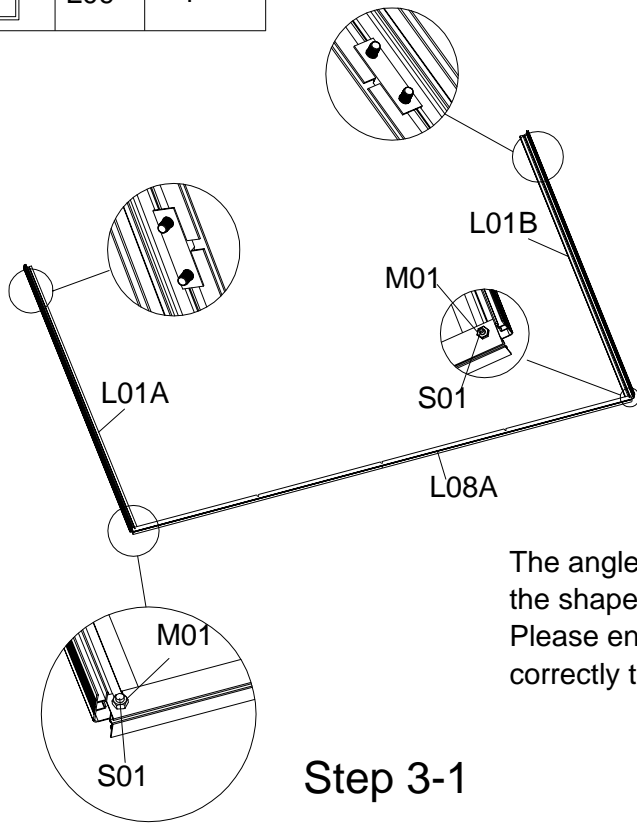

Step 3-1

The angled corner brackets are cut to suit the shape of the roof and handed. Please ensure that they are fitted correctly to each side.

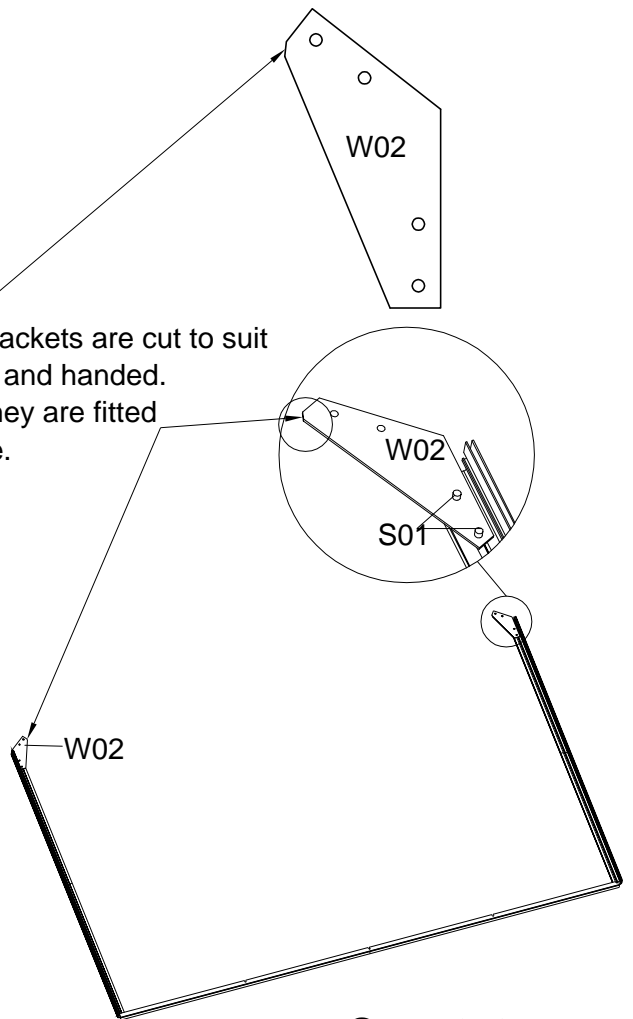

Step 3-2

The angled corner brackets are cut to suit the shape of the roof and handed. Please ensure that they are fitted correctly to each side.

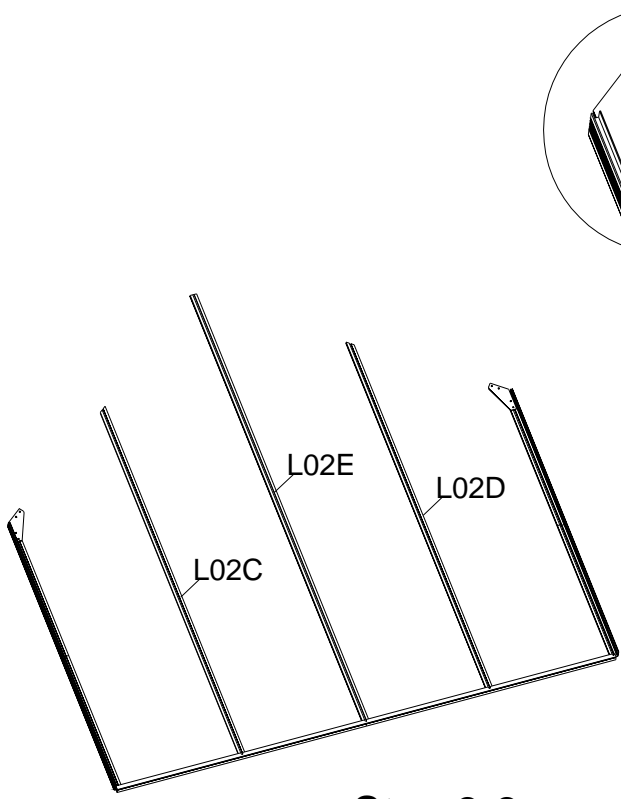

Step 3-3

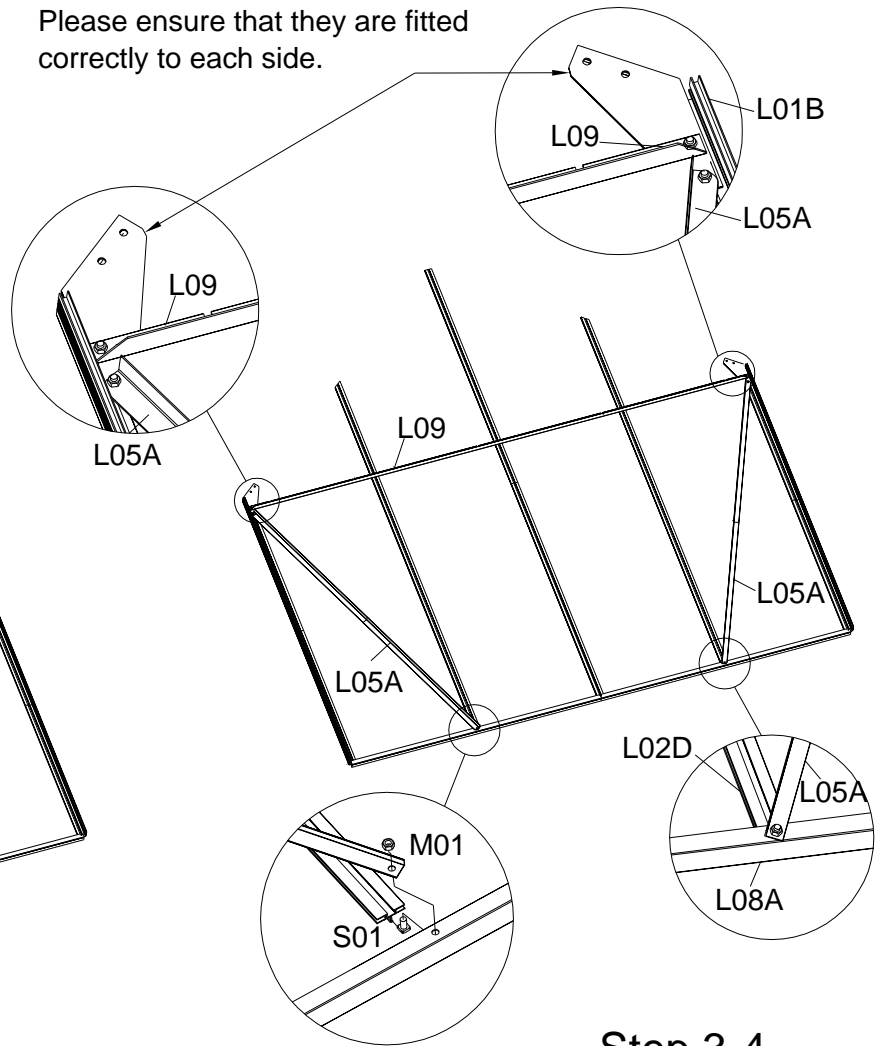

Step 3-4

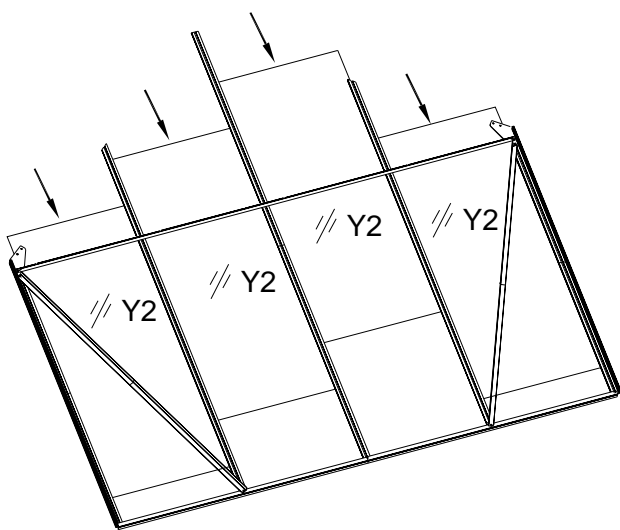

Step 3-5

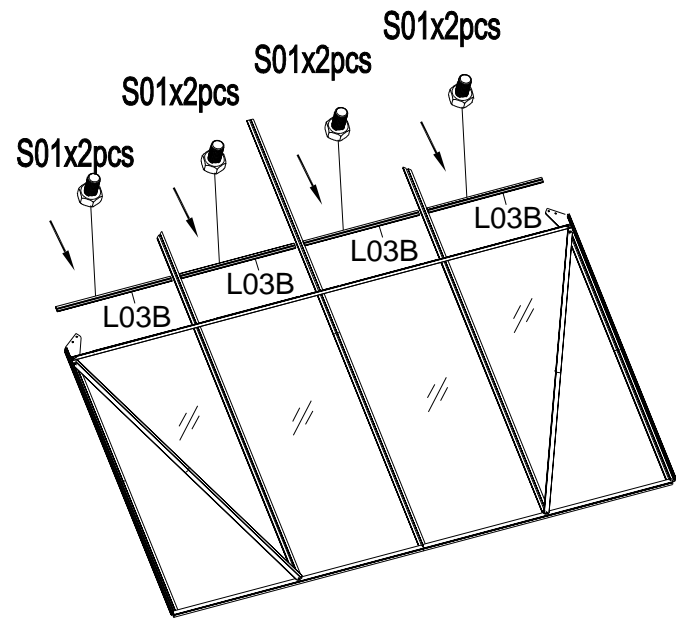

Step 3-6

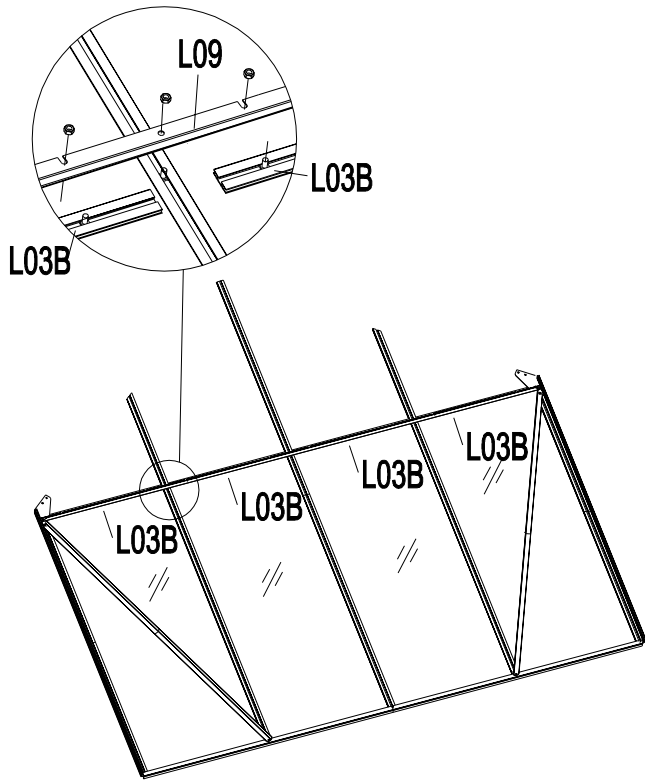

Step 3-7

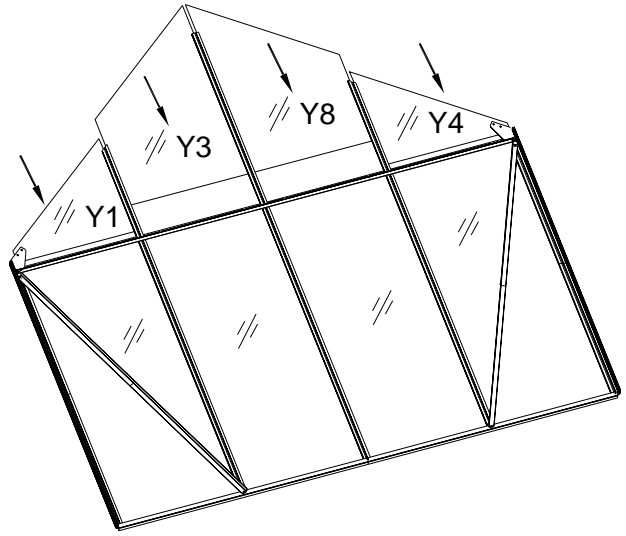

Step 3-8



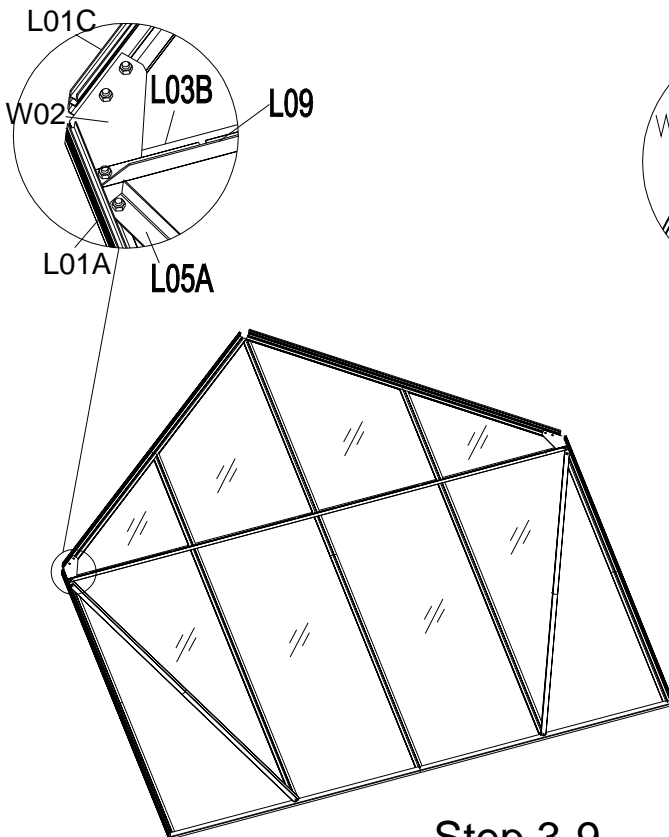



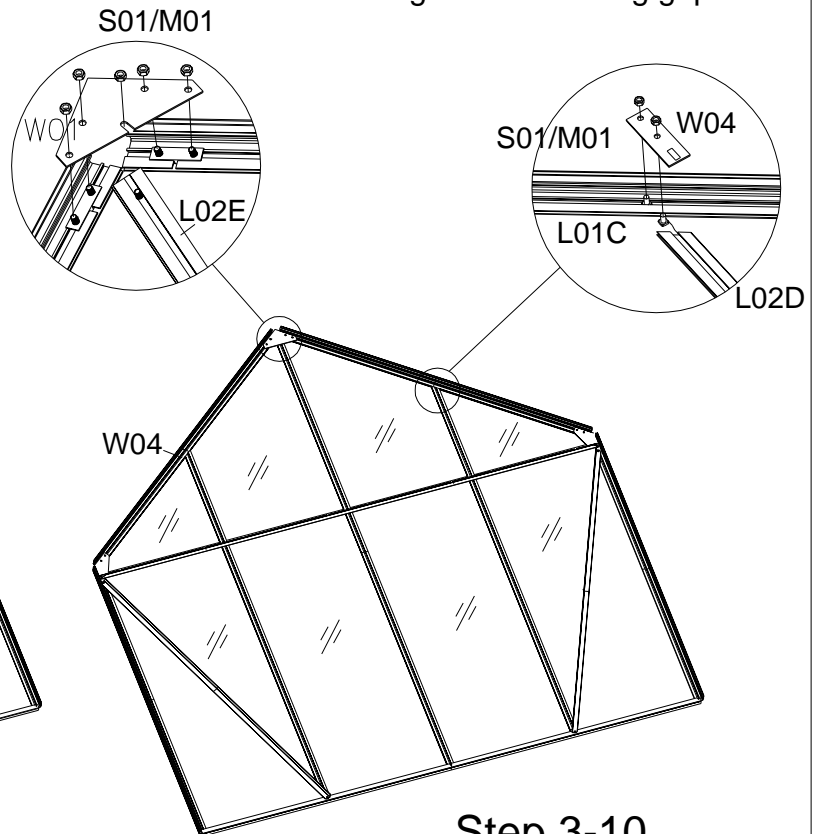





Use W04 to fix L02D and L01C together. The aluminium components should be a tight fit with no big gaps.



Step 3-9



Step 3-10

Part	NO.	QTY.
	L01A	1
	L01B	1
	L01D	1
	L01E	1
	L03A	1
	L03B	2
	L03T	1
	L04A	1
	L04B	1
	L05A	2
	L05B	2
	L10	1
	L14	1

(P8-P11)Front Wall

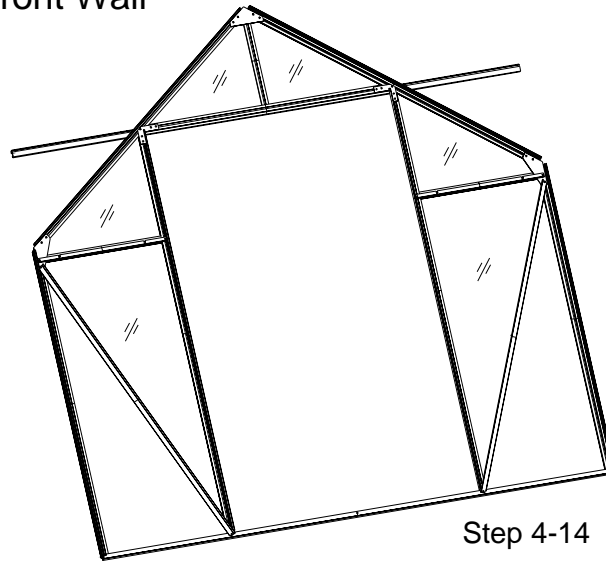

Step 4-14

The angled corner brackets are cut to suit the shape of the roof and handed. Please ensure that they are fitted correctly to each side.

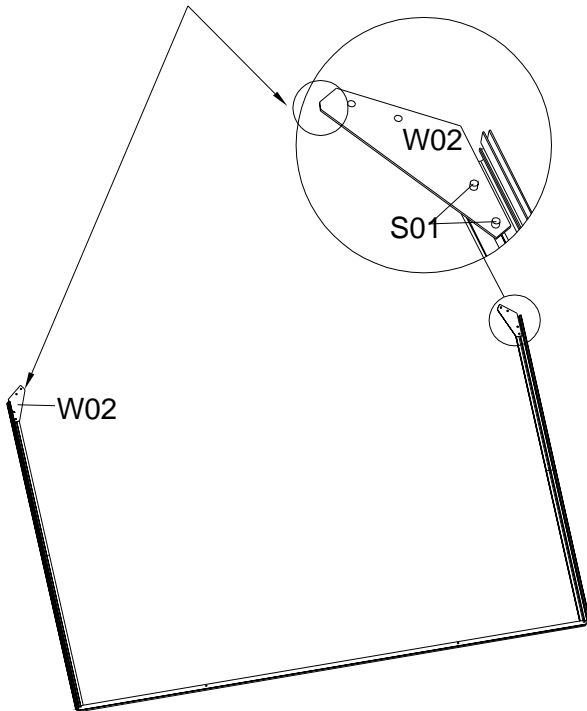

Step 4-2

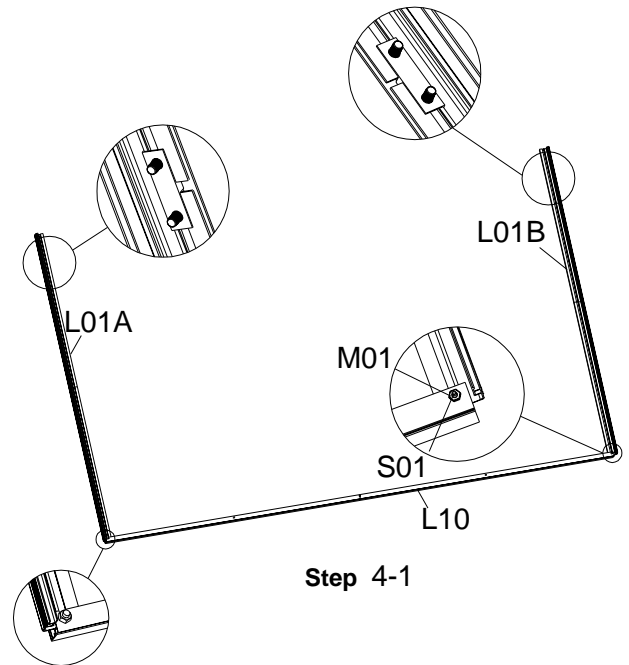

Step 4-1

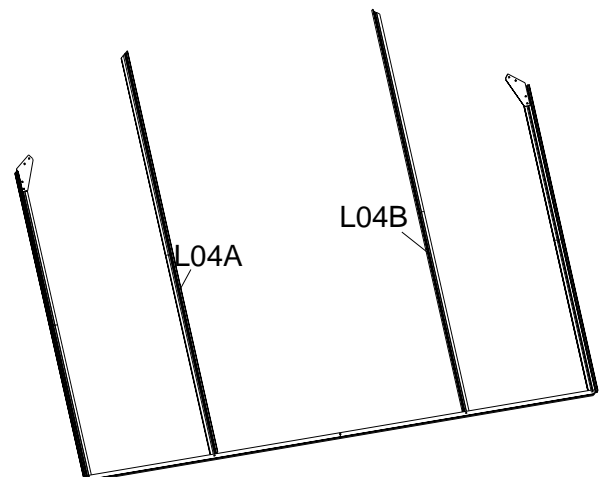

Step 4-3

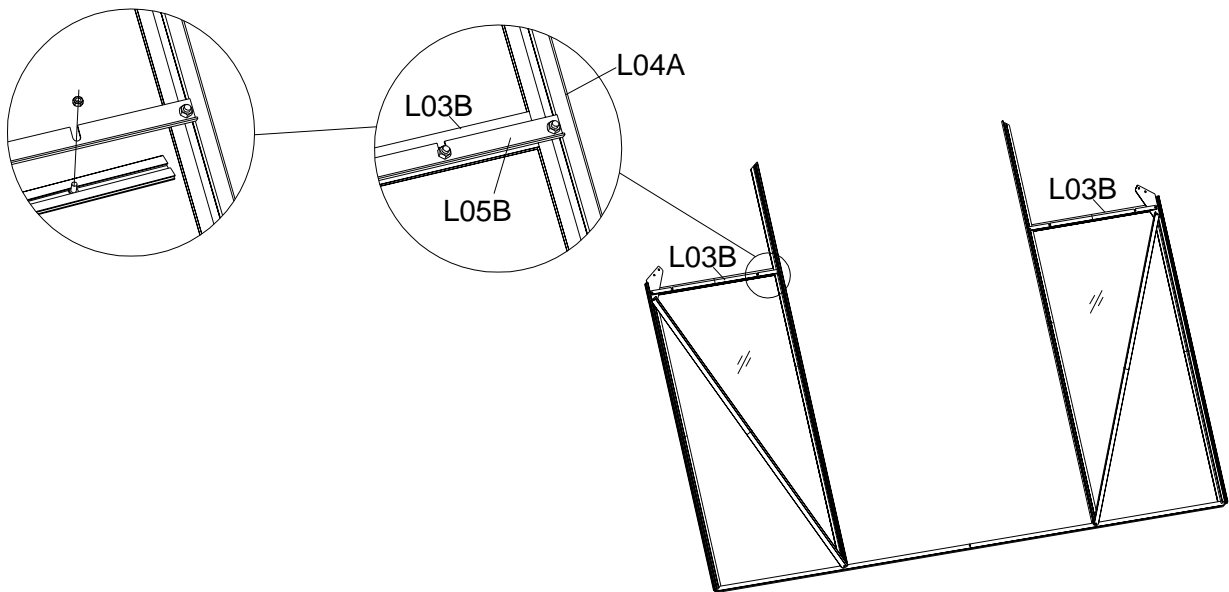
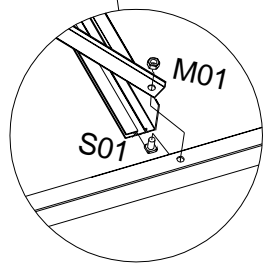
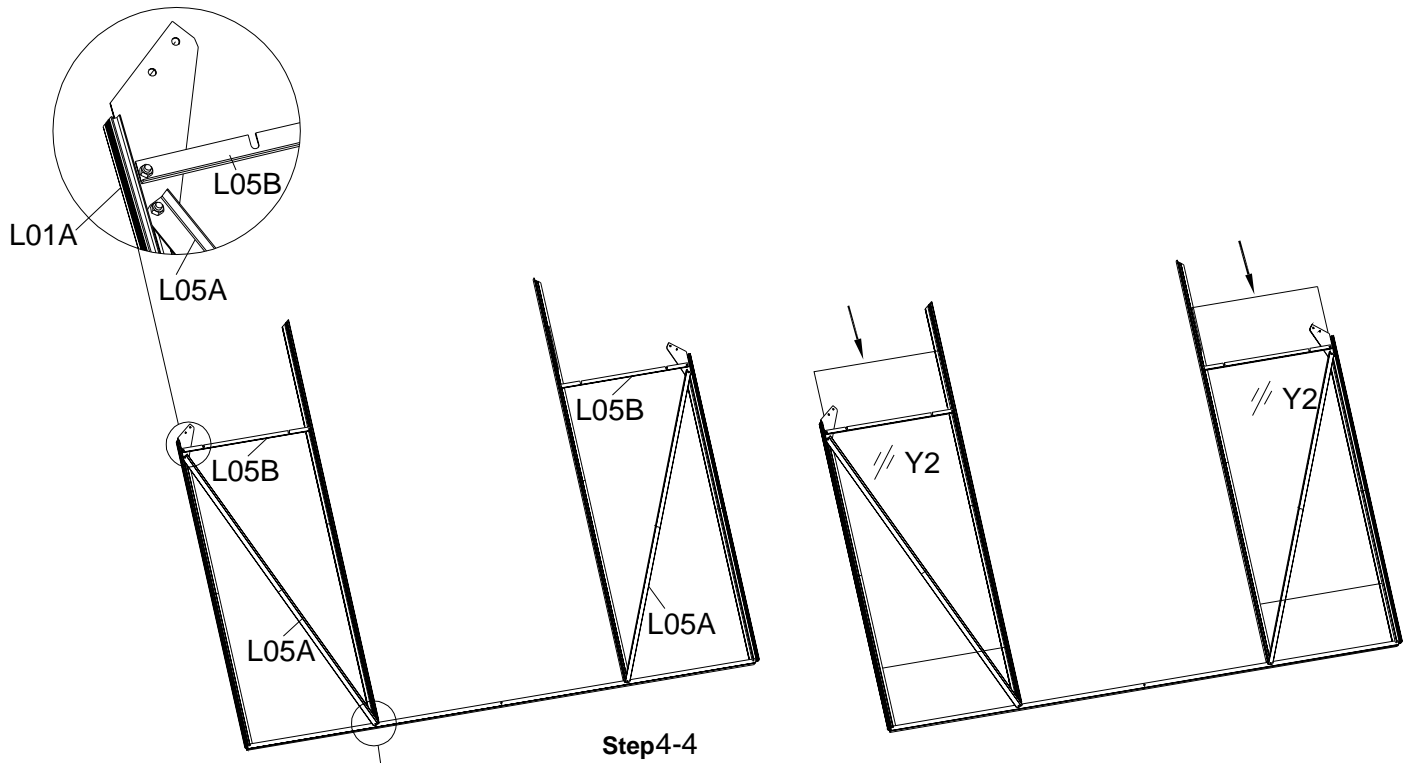

Step 4-6

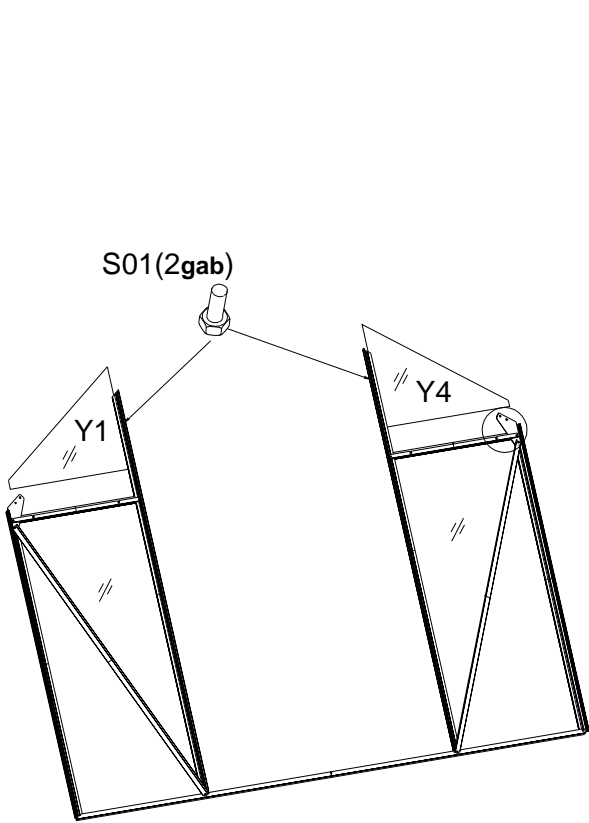

Step4-7

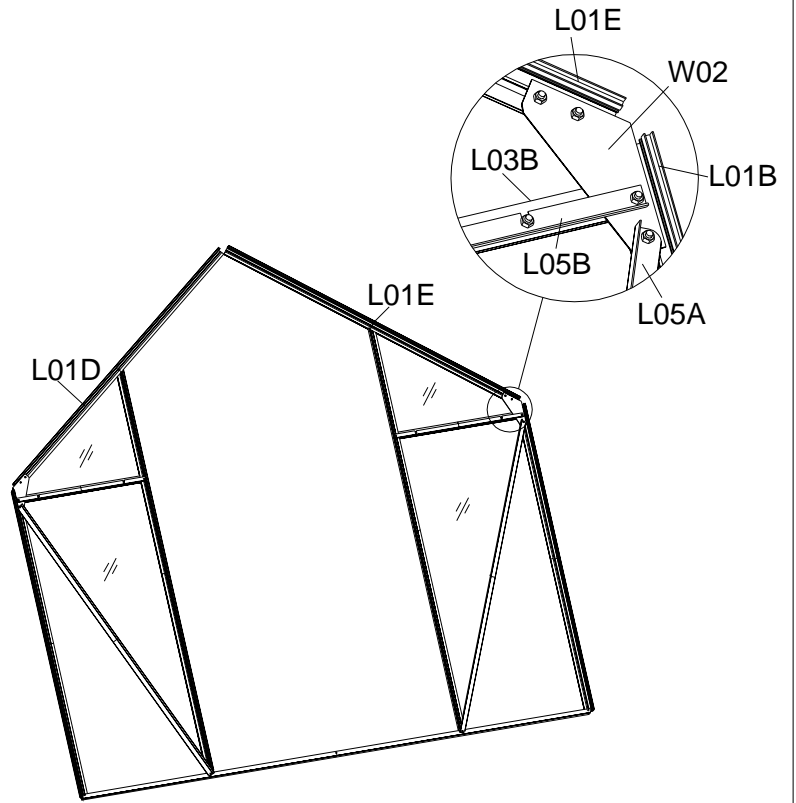

Step 4-8

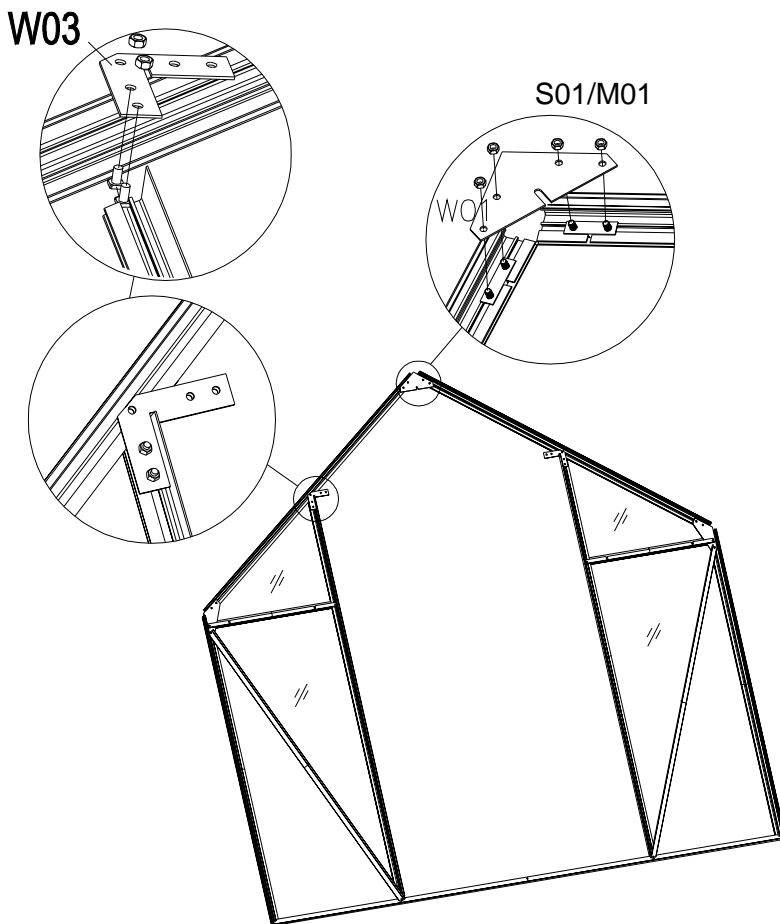

Step 4-9

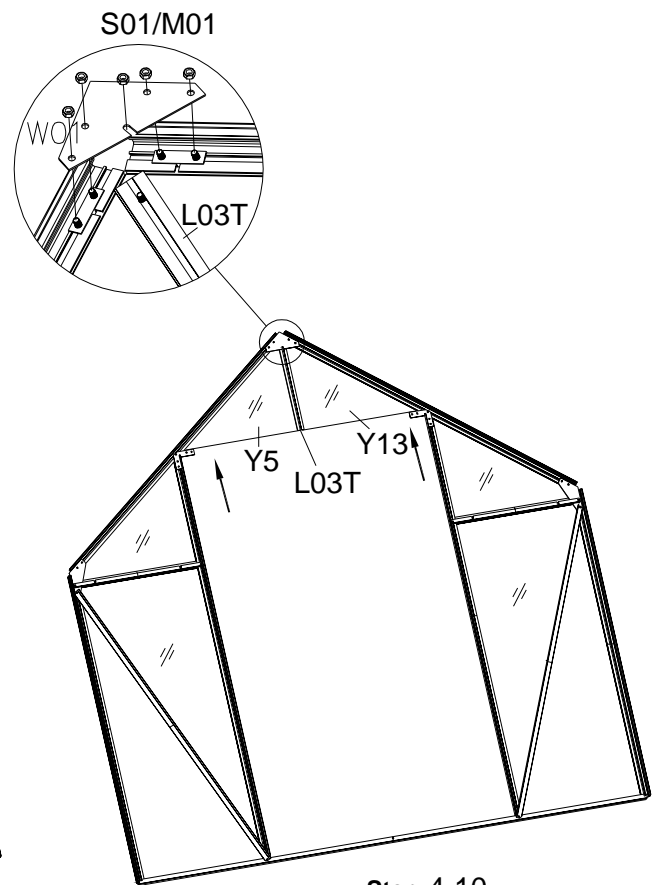

Step 4-10

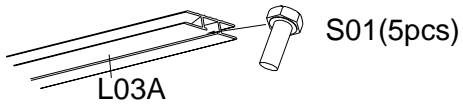

Step 4-11

M01/S01

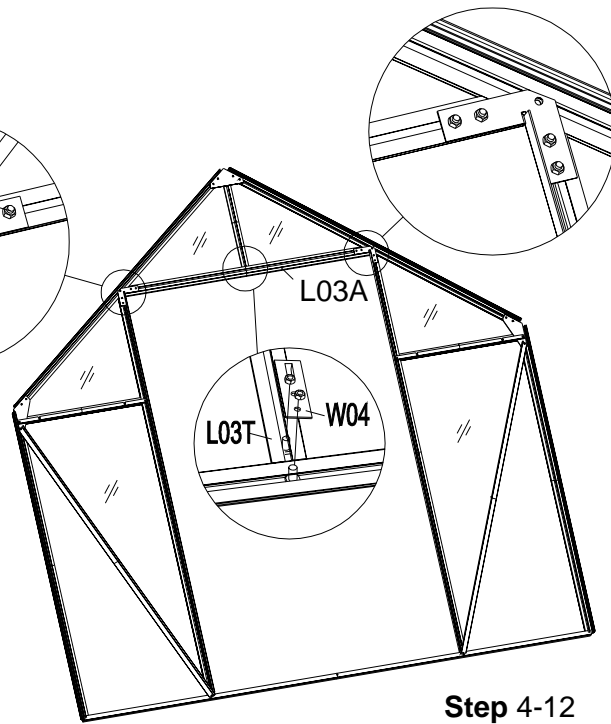
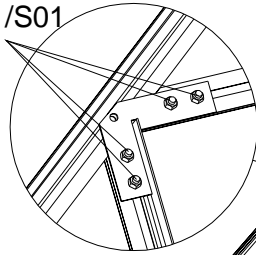

Step 4-12

Use S02 and M01 to fix W03 in position.
The aluminium components should be a tight fit with no big gaps.

S02/M01

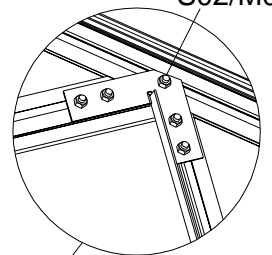
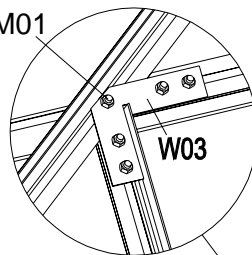

L14

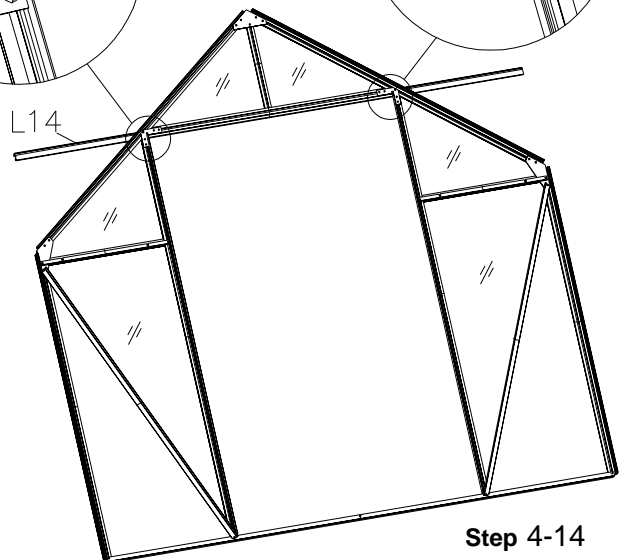





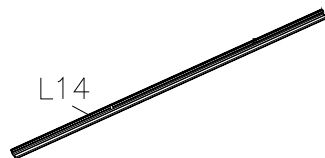
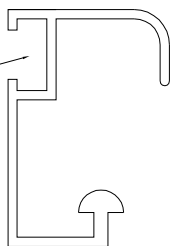





Step 4-14

! S02(2pcs)



Step 4-13

Part	NO.	QTY.
	L02A	6
	L02B	6
	L03B	2
	L05C	4
	L05D	4
	L05E	3
	L05F	6
	L06	1
	L07	2
	L08B	2

(P12-P20) Sides and Roof

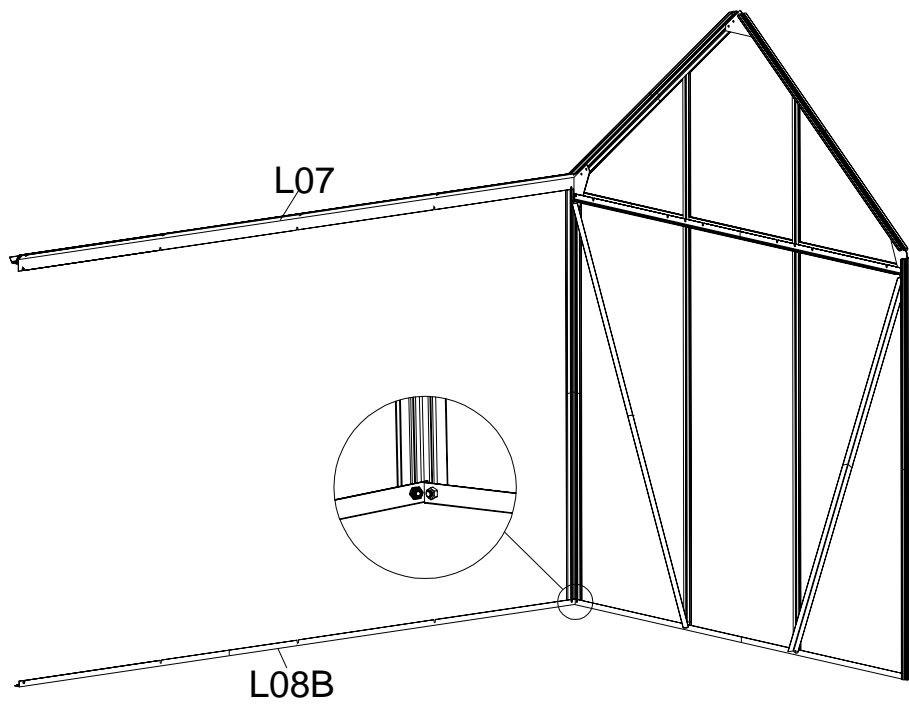

Step 5

Important: please make sure that you insert 3PCS S01 into the channel of each L02A, 1 bolt is needed later to fix the bracing.

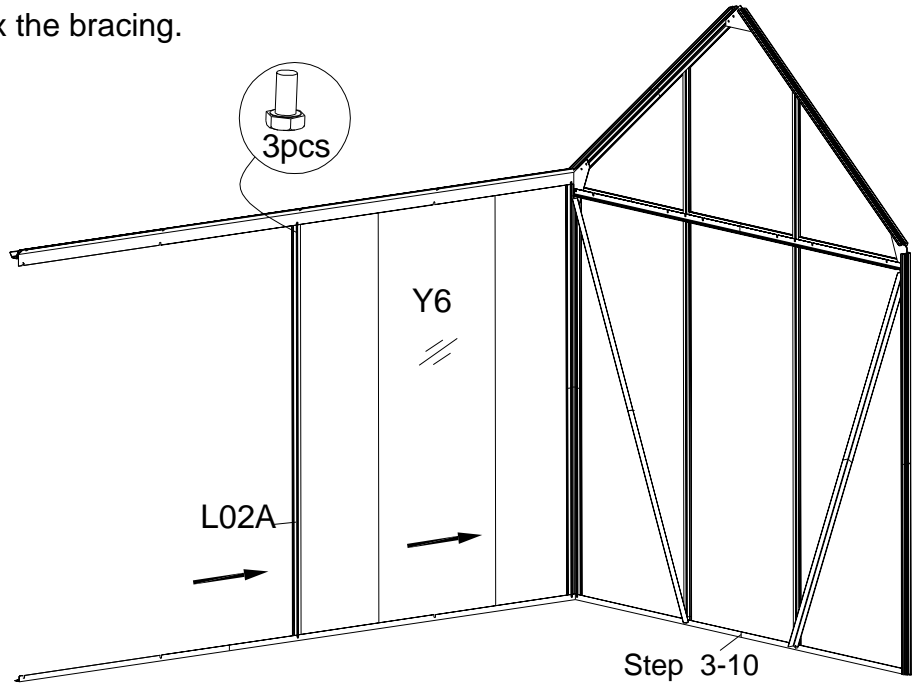
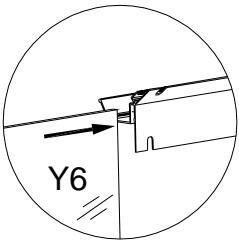

Step 6

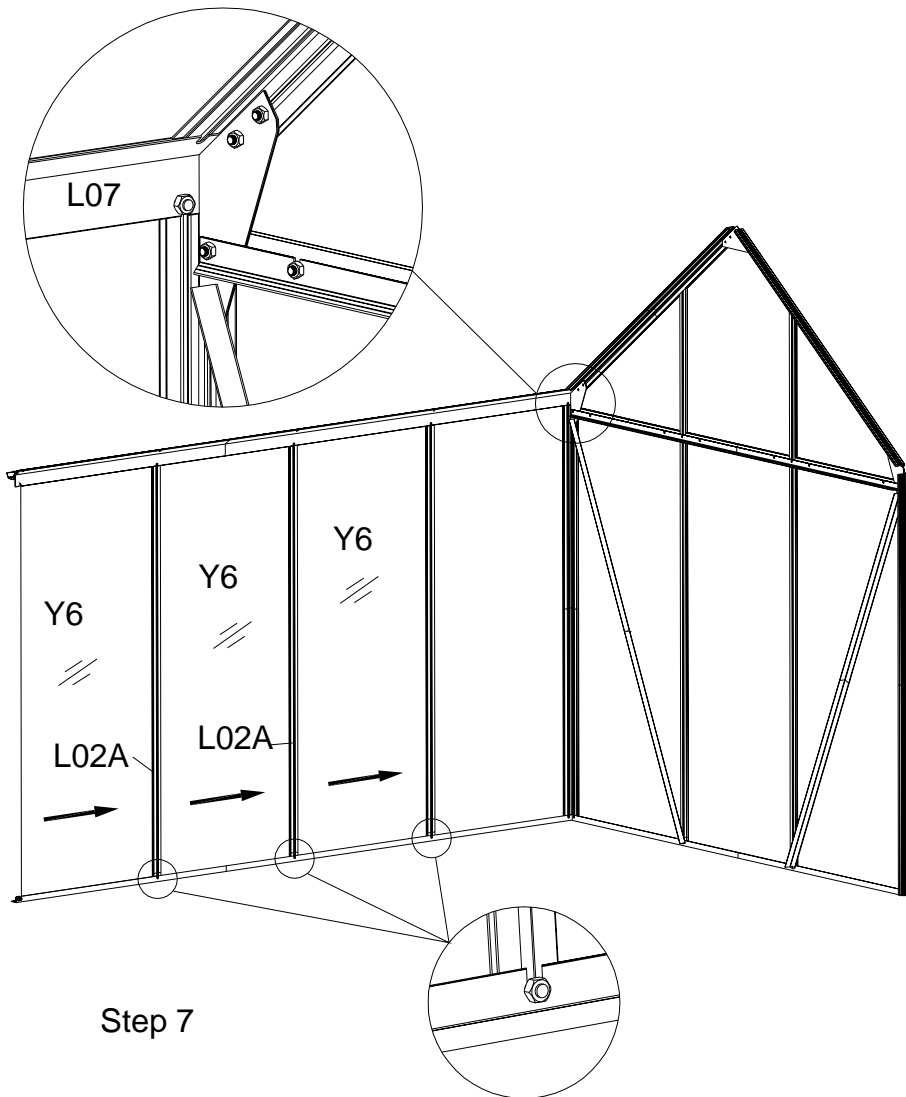

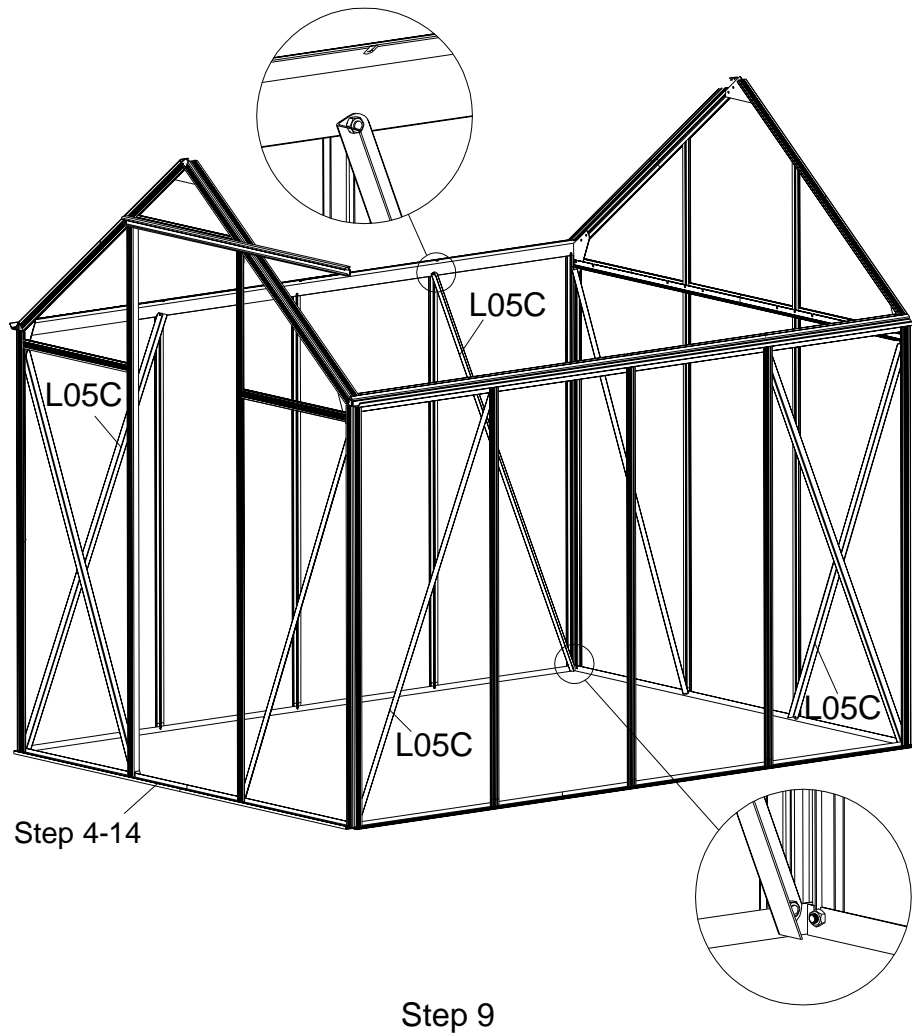
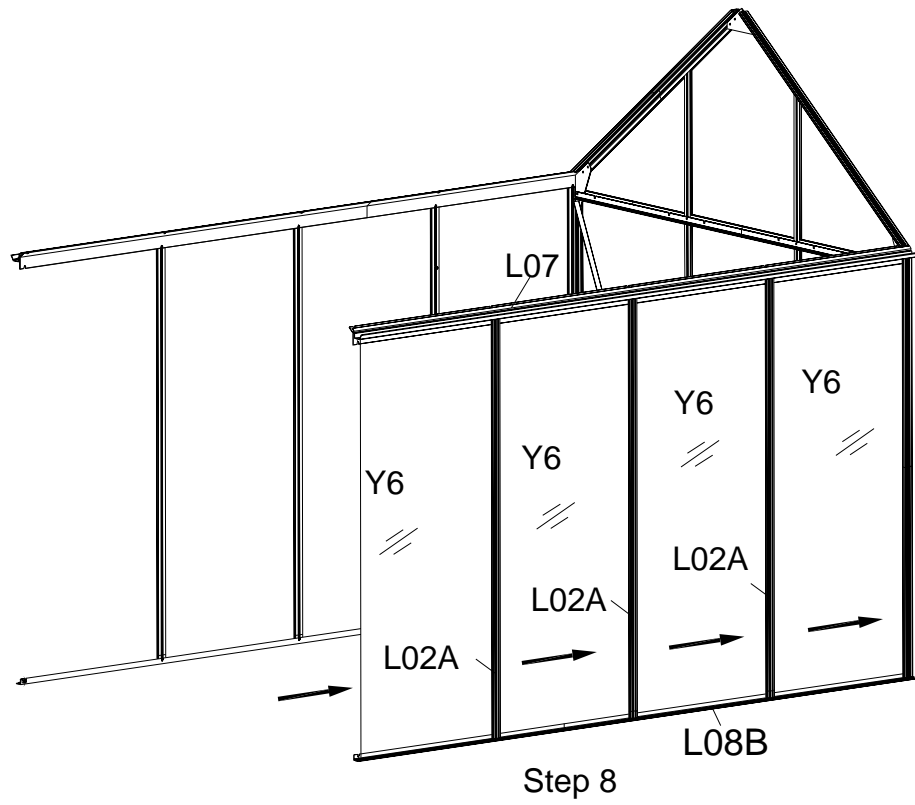

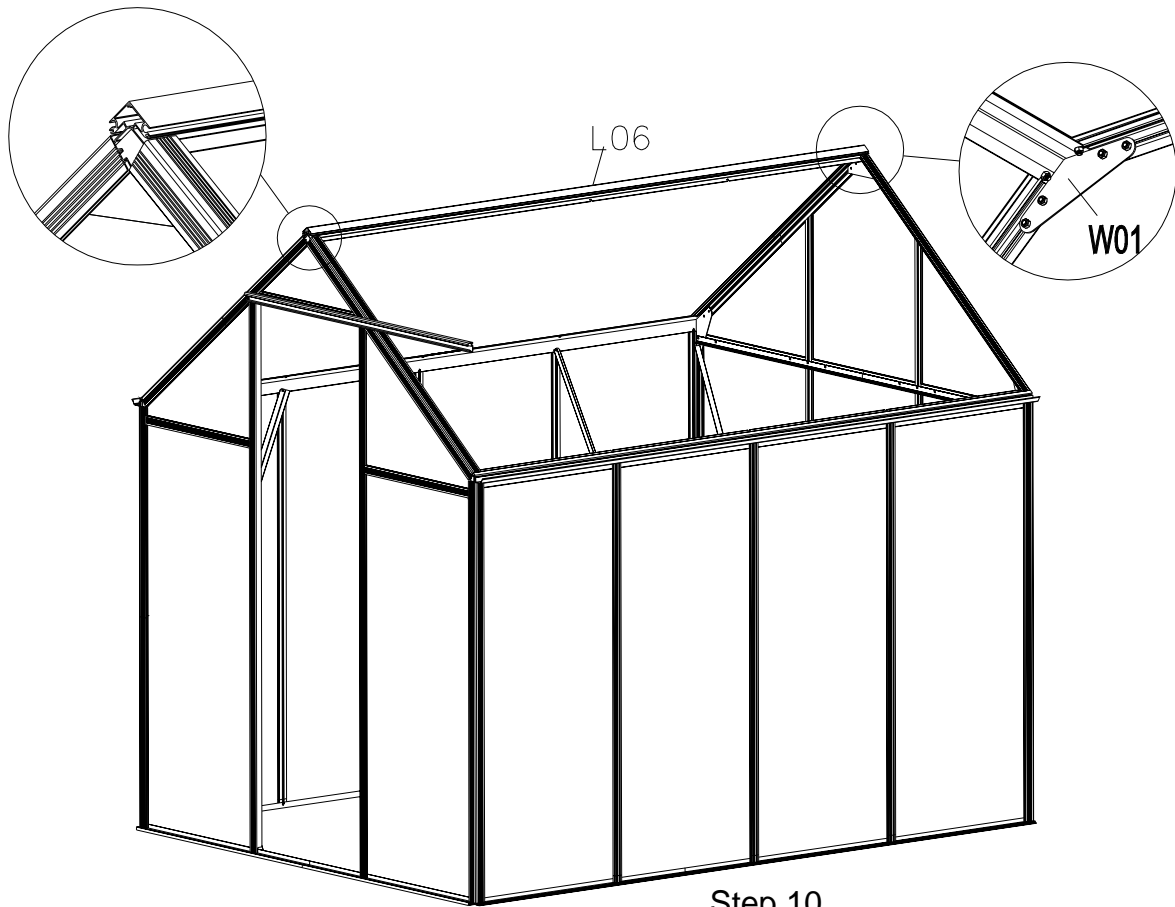

Step 10

Important: please make sure that you insert 4pcs S01 into the channel of each L02B, 2pcs are needed later to fix the bracing and window vents.

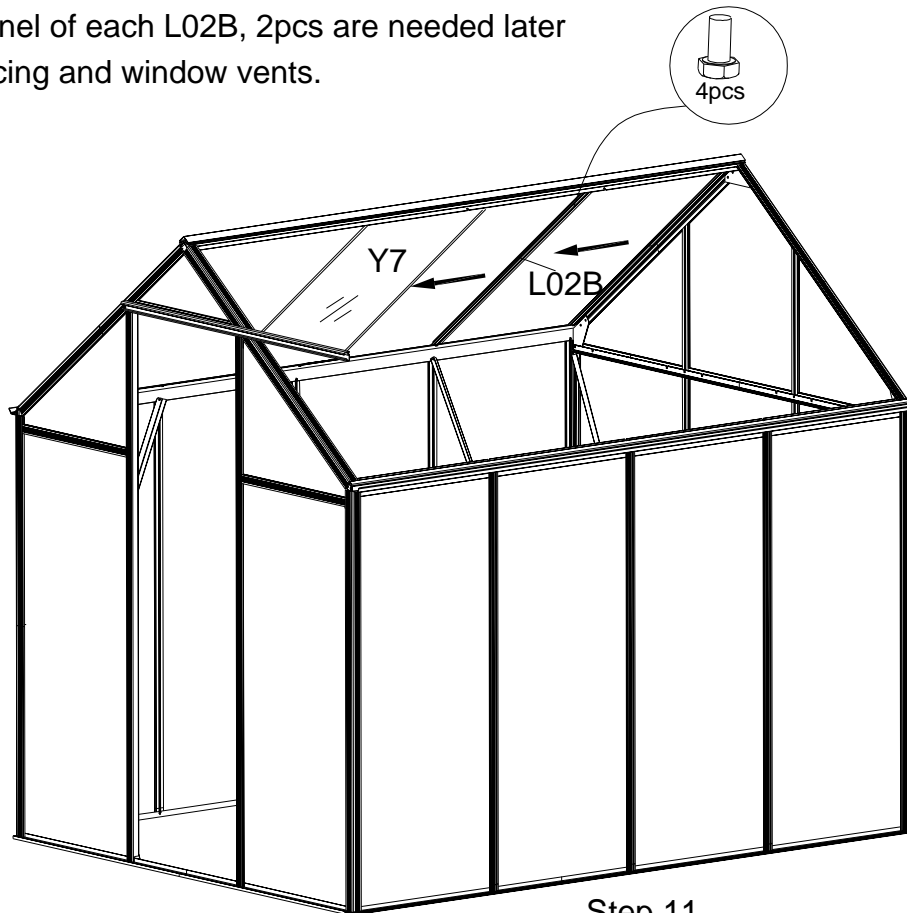

Step 11

Important: please make sure that you insert 5pcs S01 into the channel of each L02B, 3pcs are needed later to fix the bracing and window vents.

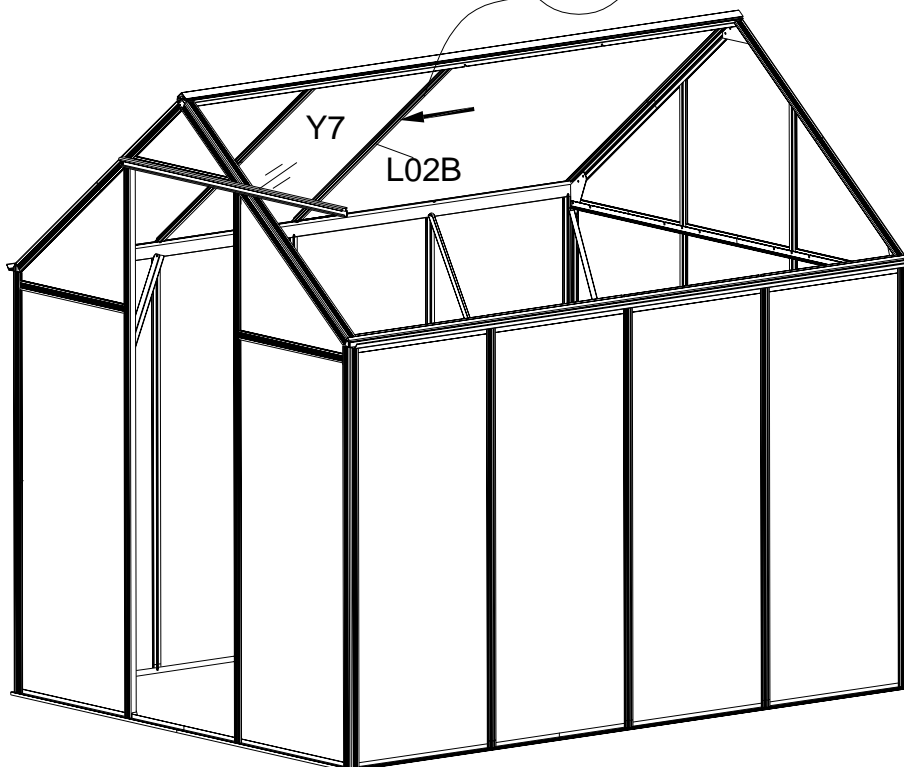

Step 12

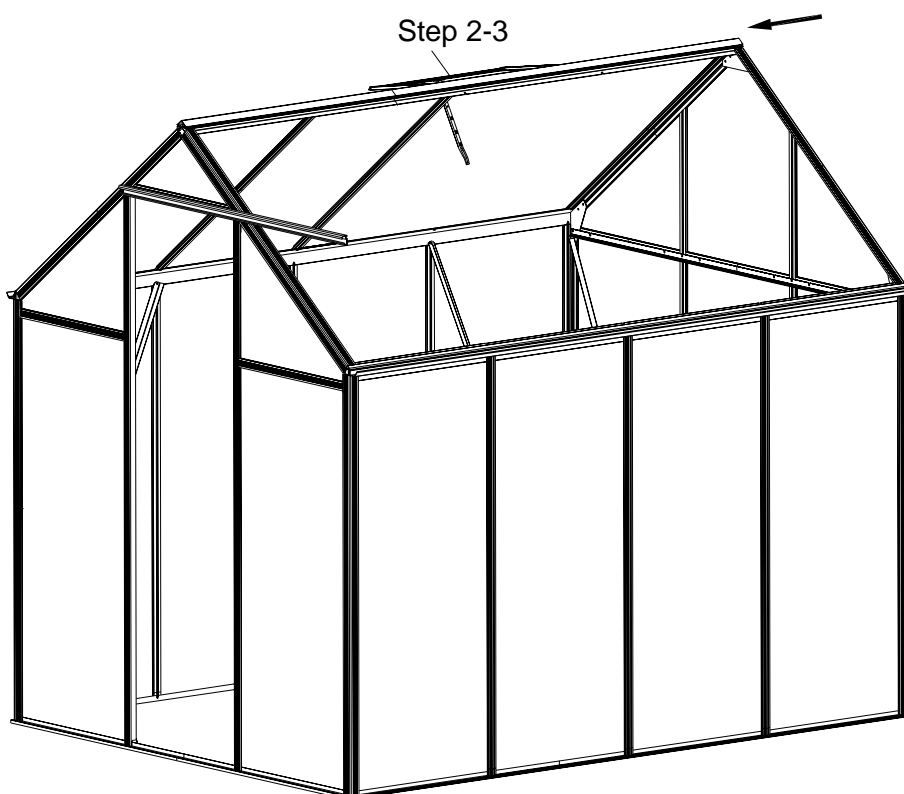

Step 13

Important: please make sure that you insert 5pcs S01 into the channel of each L02B, 3pcs are needed later to fix the bracing and window vents.

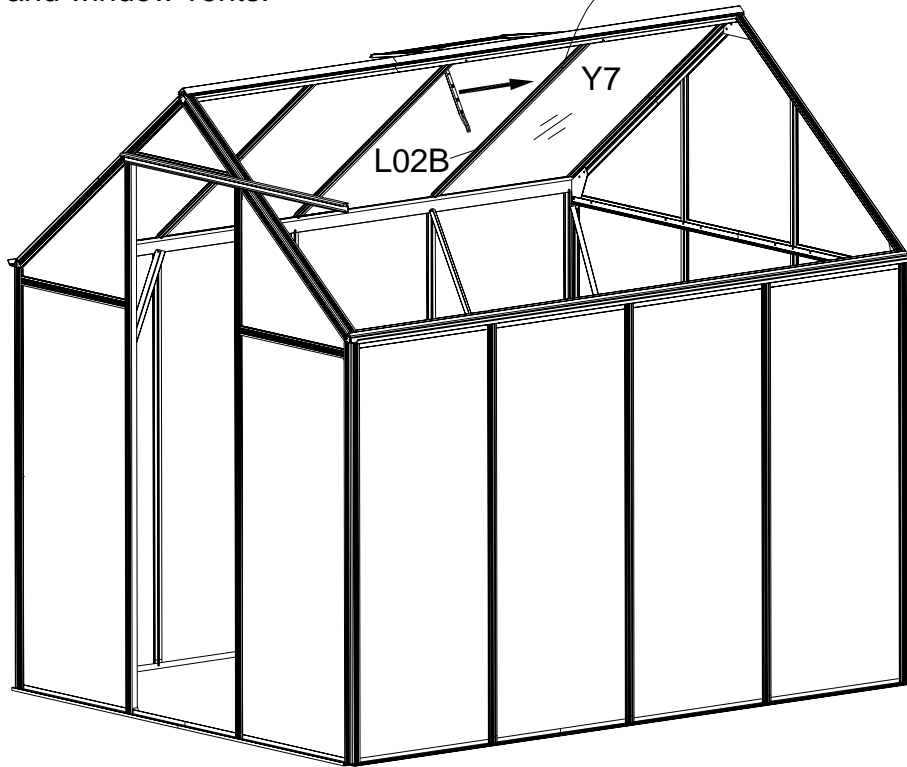
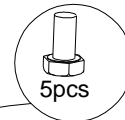

Step 14

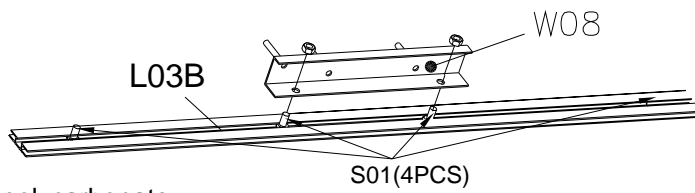

IMPORTANT

Y9 is the last piece of polycarbonate to be fitted. Slide L03B upwards before fitting Y9 and then slide it back over Y9 to lock it in position. Gently bend the sheet to pop it into the extrusion.

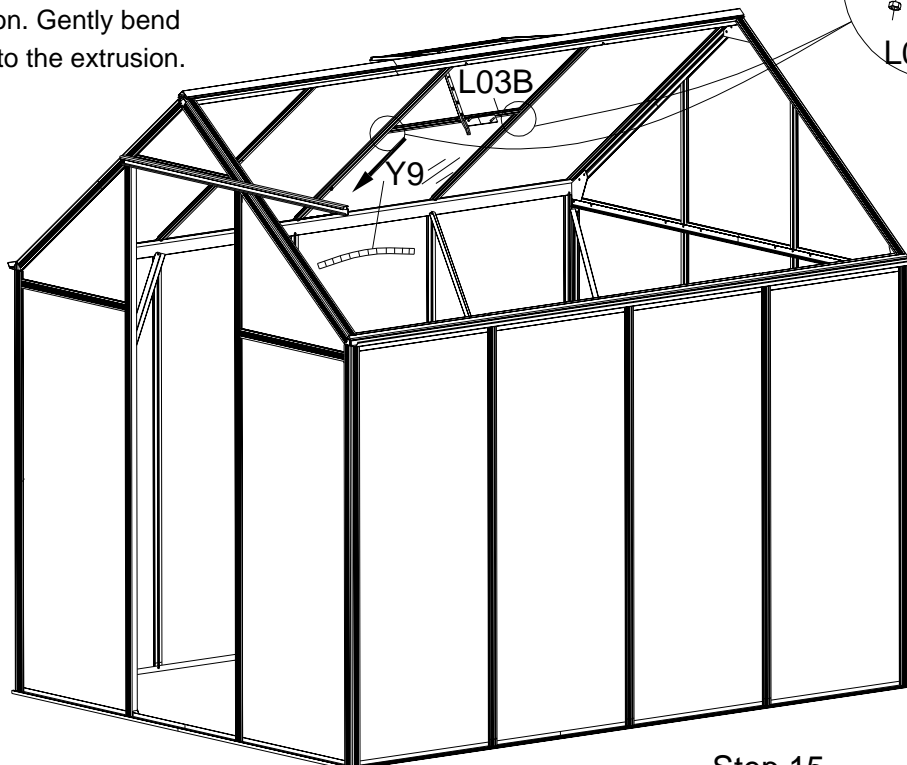
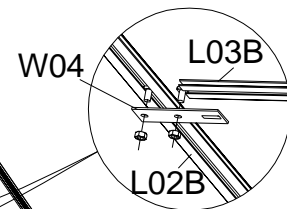

Step 15

Important: please make sure that you insert 5pcs S01 into the channel of each L02B, 3pcs are needed later to fix the bracing and window vents.

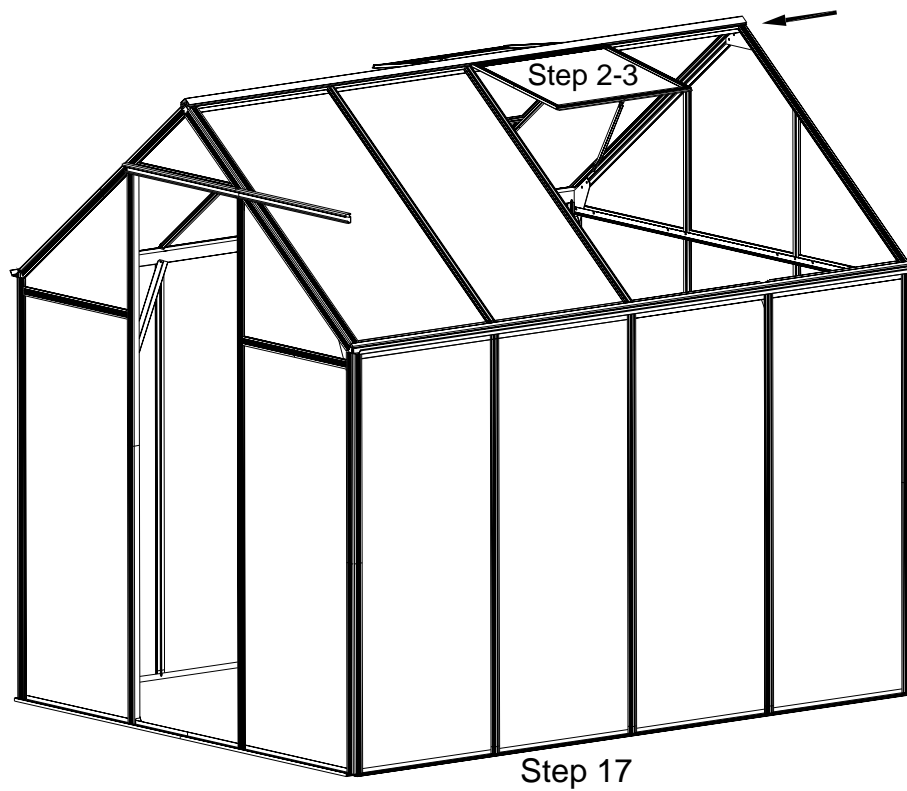
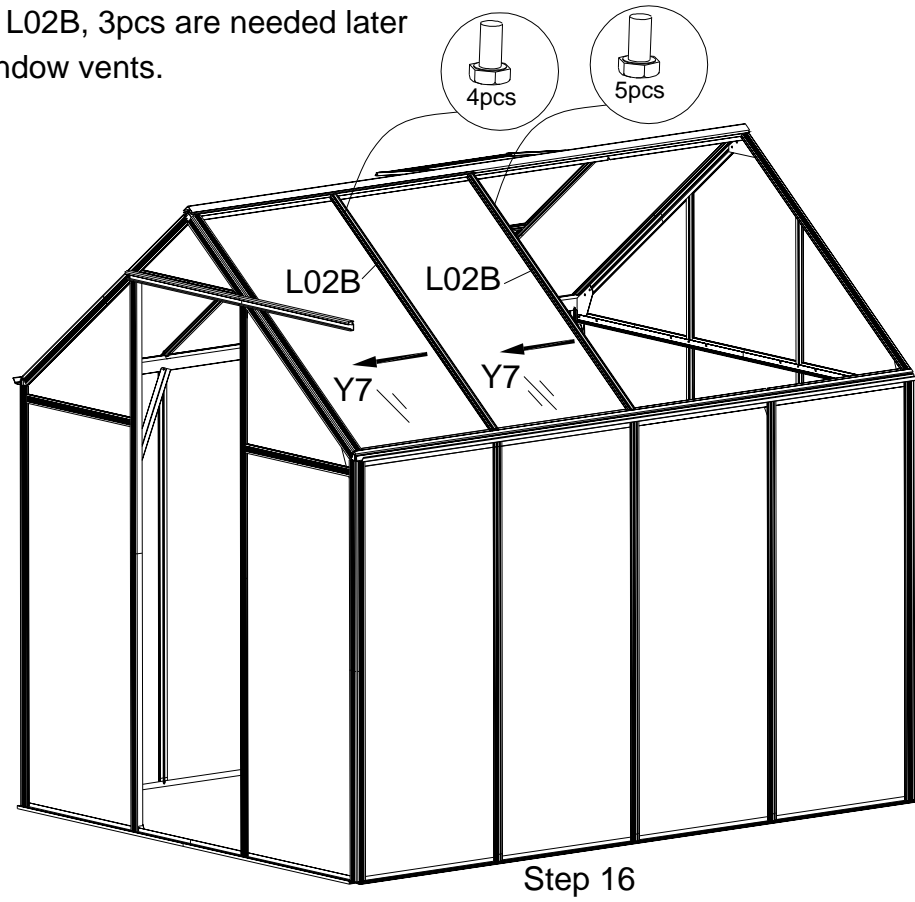

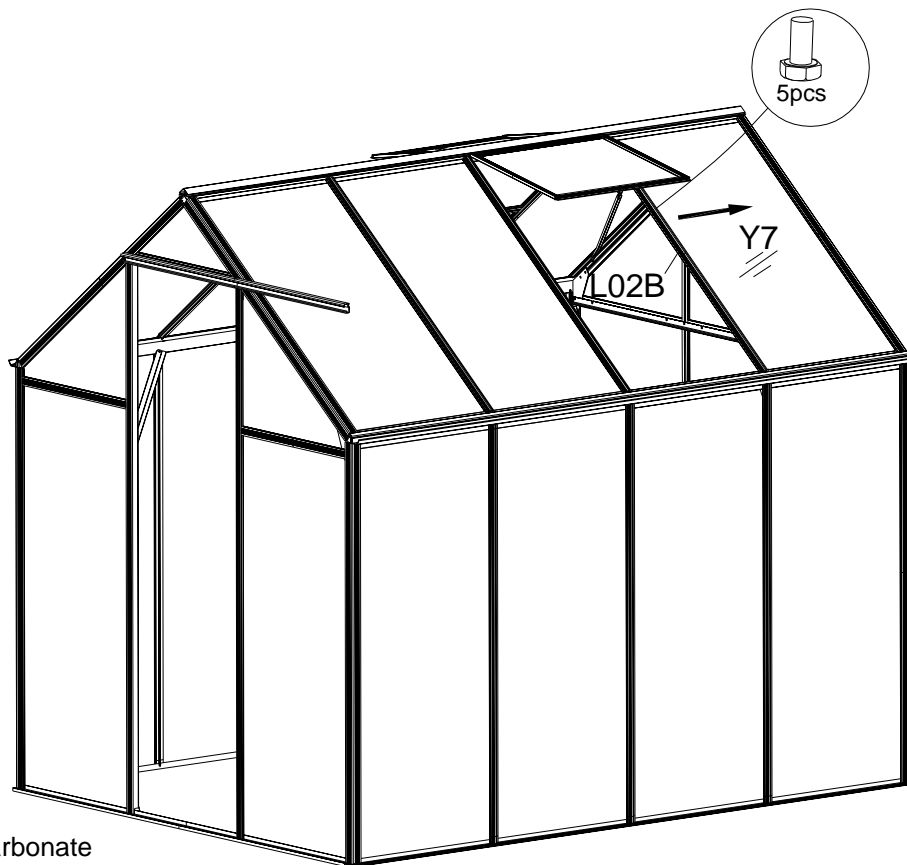

IMPORTANT

Y9 is the last piece of polycarbonate to be fitted. Slide L03B upwards before fitting Y9 and then slide it back over Y9 to lock it in position. Gently bend the sheet to pop it into the extrusion.

Step 18

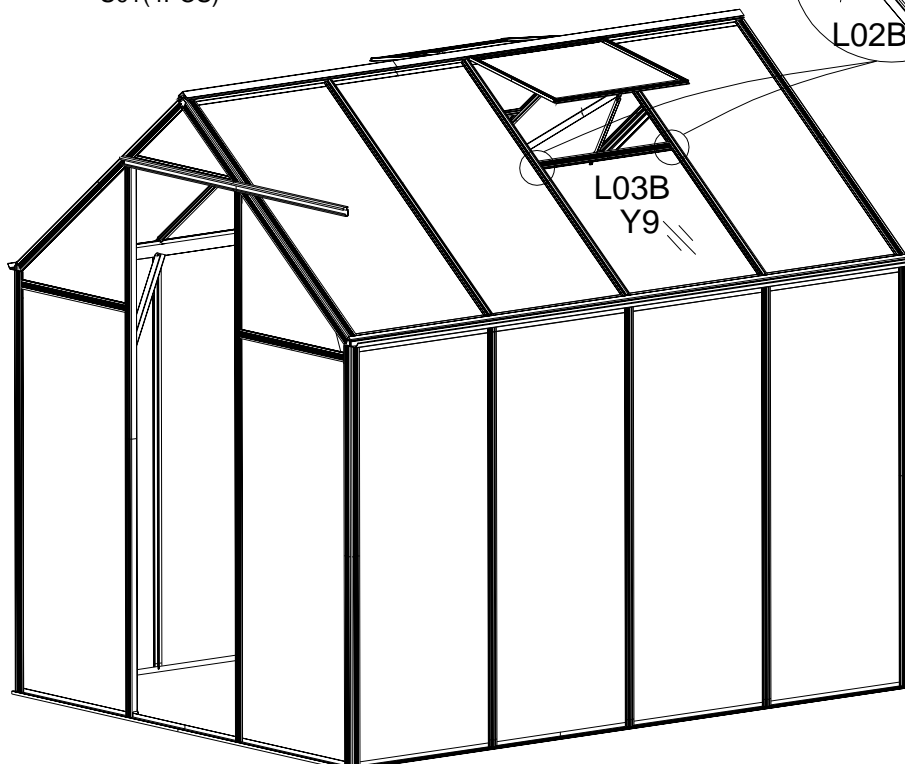
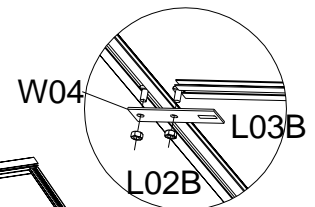
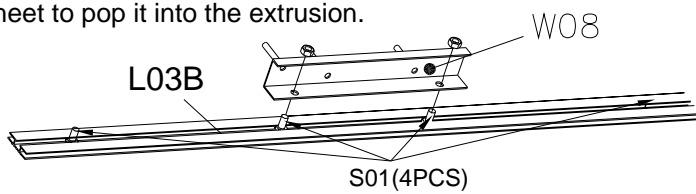

Step 19

